

AM · FM · TELEVISION

BROADCAST

NEWS

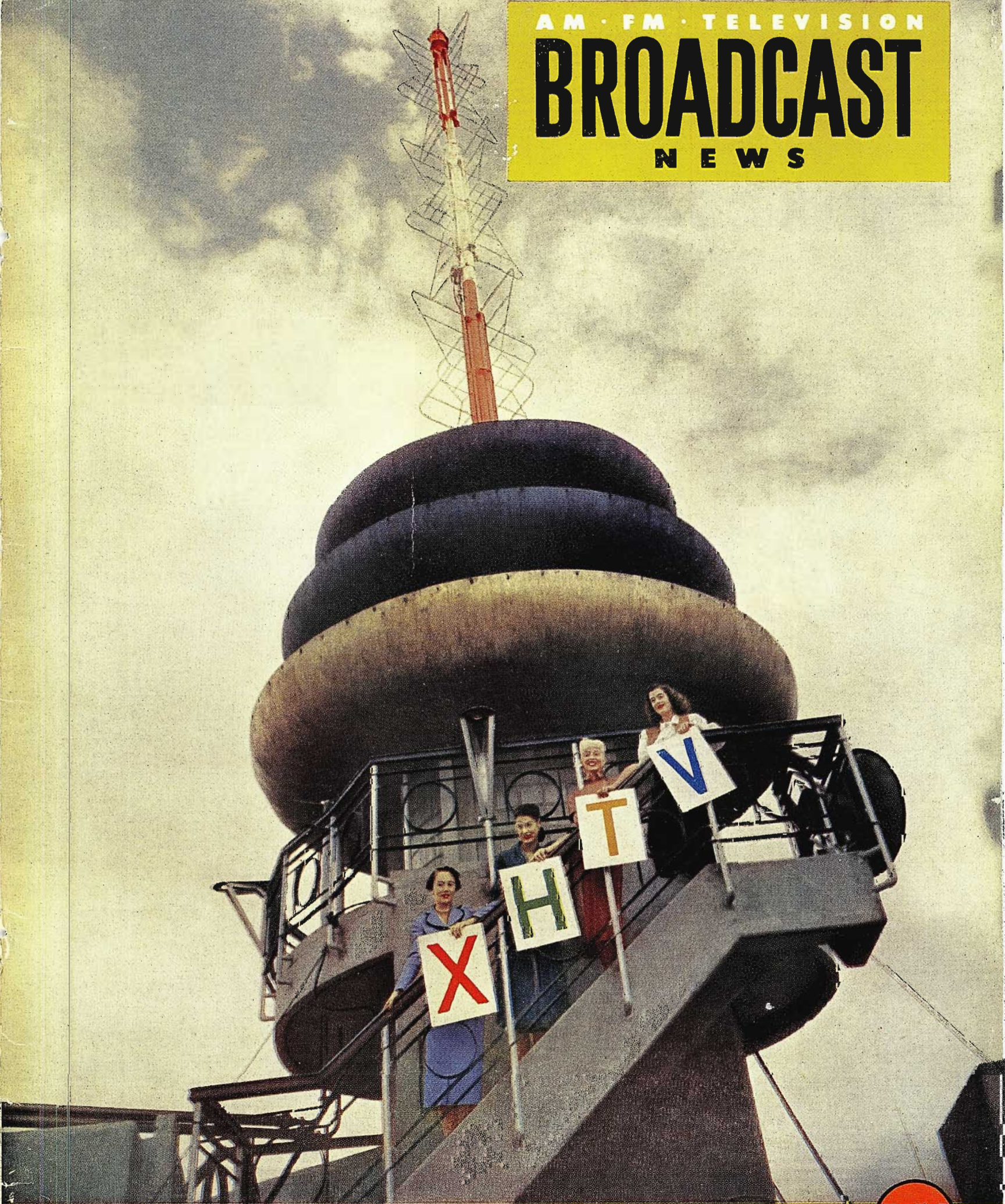

FOUR RCA TV TRANSMITTERS IN LATIN AMERICA . . . See Pg. 8



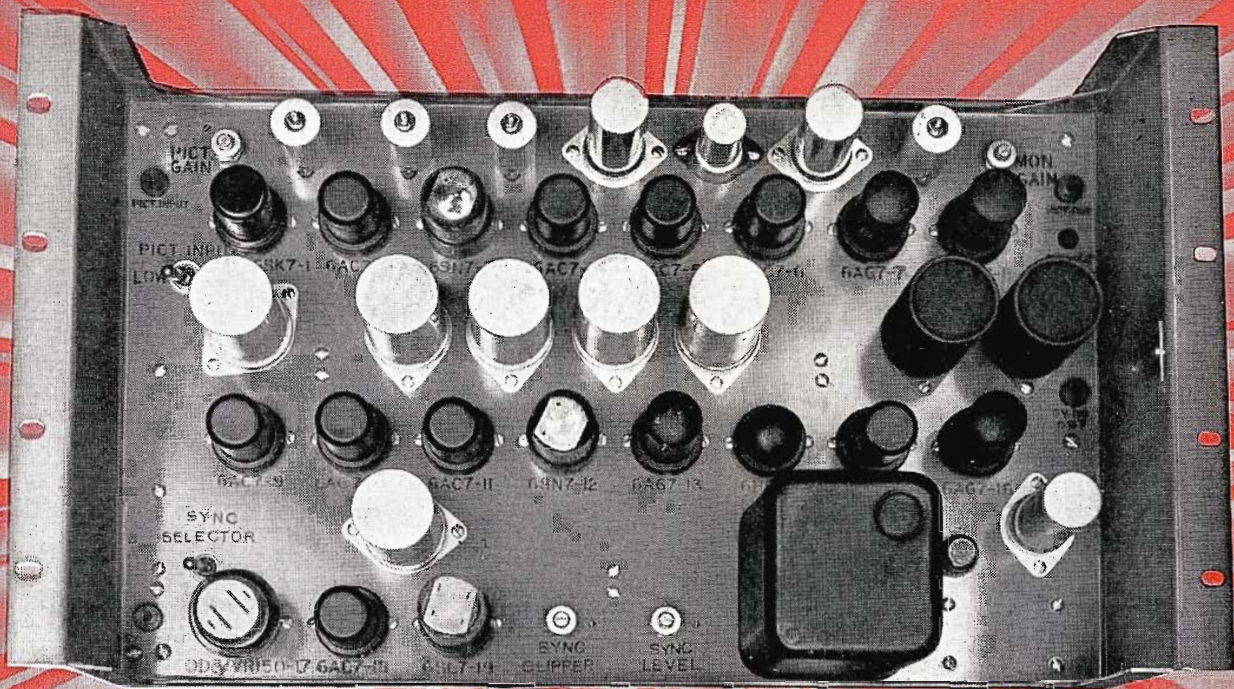

**RCA Stabilizing Amplifier
Type TA-5C for TV Stations
Over 400 now in use**

Best in the Business **—take stability, for instance**

● Stability—the most necessary requirement of any stabilizing amplifier—is a “standout” feature of the TA-5C. It is absolutely stable under all operating conditions. It operates with the same stability with or without signal input. It provides complete isolation between monitors—makes it possible to perform on-air monitor switching operations without creating transients or cross-talk on the program line.

The TA-5C stabilizing amplifier handles sync inputs up to 8 volts—and delivers signal voltage output at

standard RMA values through just one simple adjustment of the sync control. Total tube complement—only 19!

Today more than 400 RCA Stabilizing Amplifiers are helping TV stations deliver the cleanest, most stable pictures in the history of commercial television. *Need we say more?*

Call your RCA representative for price and information on delivery.



TELEVISION BROADCAST EQUIPMENT
RADIO CORPORATION of AMERICA
ENGINEERING PRODUCTS DEPARTMENT, CAMDEN, N. J.

In Canada: RCA VICTOR Company Limited, Montreal

Broadcast News

AM • FM • TELEVISION

• • •

Published by the

RADIO CORPORATION OF AMERICA

ENGINEERING PRODUCTS DEPARTMENT . . . CAMDEN, NEW JERSEY

NUMBER 62

January-February, 1951

Subscription Rates

In continental U. S. A. - \$4.00 for 12 issues

In other countries - - - - \$5.00 for 12 issues

JOHN P. TAYLOR, Editor

W. O. HADLOCK, Managing Editor

M. L. GASKILL, E. B. MAY, Associate Editors

Contents

FCC AUTHORIZES STUDIO-TRANSMITTER LINK FOR AM, FM AND TV BROADCAST STATIONS . . .	by R. J. NEWMAN	4
RCA TELEVISION . . . NEW LINK FOR THE AMERICAS	by MEADE BRUNET	8
KSD AND KSD-TV, ST. LOUIS	by GEORGE M. BURBACH	22
KSD's AM FACILITIES	by C. R. YARGER	24
KSD TELEVISION FACILITIES	by J. E. RISK	30
THE REQUIREMENTS OF TELEVISION STATION DESIGN (PART II)	by DR. WALTER J. DUSCHINSKY	36
EMPIRE STATE TOWER NEARS COMPLETION		42
WJAC-TV, JOHNSTOWN, PENNA	by NEVIN L. STRAUB	50
DESIGN OF MOBILE TWO-WAY RADIO COMMUNICATION EQUIPMENT AT 152-174 MC.		
	by R. A. BEERS, W. A. HARRIS, A. D. ZAPPACOSTA	56
A FLEXIBLE TV AUDIO SYSTEM	by W. L. LYNDON	66

Copyright 1951
Radio Corporation of America
RCA Victor Division
Camden, N. J.

PRINTED
IN
U.S.A.

OUR COVER illustration for this issue is a dramatic view of XHTV's three-section RCA Super Turnstile. Besides being a beautiful picture it's more evidence of what we've always said; viz., that everybody (well, nearly everybody) uses the RCA Super Turnstile—or Chinese copies of it.

SORRY about our front cover line, "Four TV Stations in Latin America". We try to keep BROADCAST NEWS up to the minute, but video is developing so rapidly in all the Americas that since we produced our cover, RCA is equipping its *fifth* Latin American station—the *third* in Havana. RCA International Division's chief, Meade Brunet, tells the story in this issue.

It is interesting to note the ownership of these stations—broadcasting organizations, newspapers, a newsreel company. The marriage of video and the movies should be interesting to watch.

The engineering, artistic, and production talents of Latin America are hitched to TV now. Our friends in Cuba, Brazil, Mexico, and the other countries will be making contributions not only to video, but also to international understanding.

We will be making it a two-way exchange. We can all use a lot of that commodity—international understanding. TV is a great medium for it.

FLASH: Just as this issue of BROADCAST NEWS was about to go to press a number of changes in the organization of the Engineering Products Department were announced. In our next issue we will tell you more about these. However, because most of the people affected are long-time friends of yours (and you'll want to know right away what they are doing) here is a quick once-over.

Wally Watts, our beloved Vice-President, has been granted a leave of absence and has gone to Washington as a special assistant to General Harrison, National Production Administrator. We're going to miss Wally something terrible—but it was a case of the country's need for him being more important than ours. As Mr. Folsom, our president, put it "General Harrison specifically asked for Wally—what could I say but yes?"

Ted Smith, who for some years has been Sales Manager of Engineering Products, and who only a few weeks ago was appointed Assistant General Manager of the Department, will be in charge of all Engineering Products operations during Mr. Watts' absence. Broadcasters, many of whom have known Ted since the days when he was our Broadcast Salesman in the New York office, will, we know, share our pleasure in Ted's promotion.

Into Ted's old job as General Sales Manager of all Engineering Products steps A. R. ("Hoppy") Hopkins, formerly manager of the Broadcast and Communications Equipment Section. "Hoppy" is another long-time member of our broadcast sales group, having been first Broadcast Sales Manager in Chicago, and later Engineering Products Regional Sales Manager for the Midwest Area, before moving to Camden in 1946.

C. M. ("Buck") Lewis, formerly Broadcast Field Sales Manager, moves up to Hoppy's former job as Manager of the Broadcast and Communications Equipment Section. Buck started in broadcasting as an engineer at WREN while he was still in school. On graduating from the University of Kansas in 1934 he joined RCA's broadcast engineering group, later transferred to sales and has successively held positions as Audio Sales Manager, Engineering Products Regional Manager, and Broadcast Field Sales Manager, before being appointed to his new position where he will be in charge of all sales activities of the Broadcast and Communications Equipment Section.

In his new post Mr. Lewis will be ably assisted by E. C. (Ed) Tracy, as Manager of Broadcast Sales, and Dana Pratt, as Manager of Communications and Microwave Equipment Sales. Both Ed and Dana are former RCA Broadcast Salesmen and are well-known in broadcast circles.

In addition to these home office sales organization changes a number of changes are being made in merchandising and field sales assignments. These we will report in the next issue.

RCA
Announces

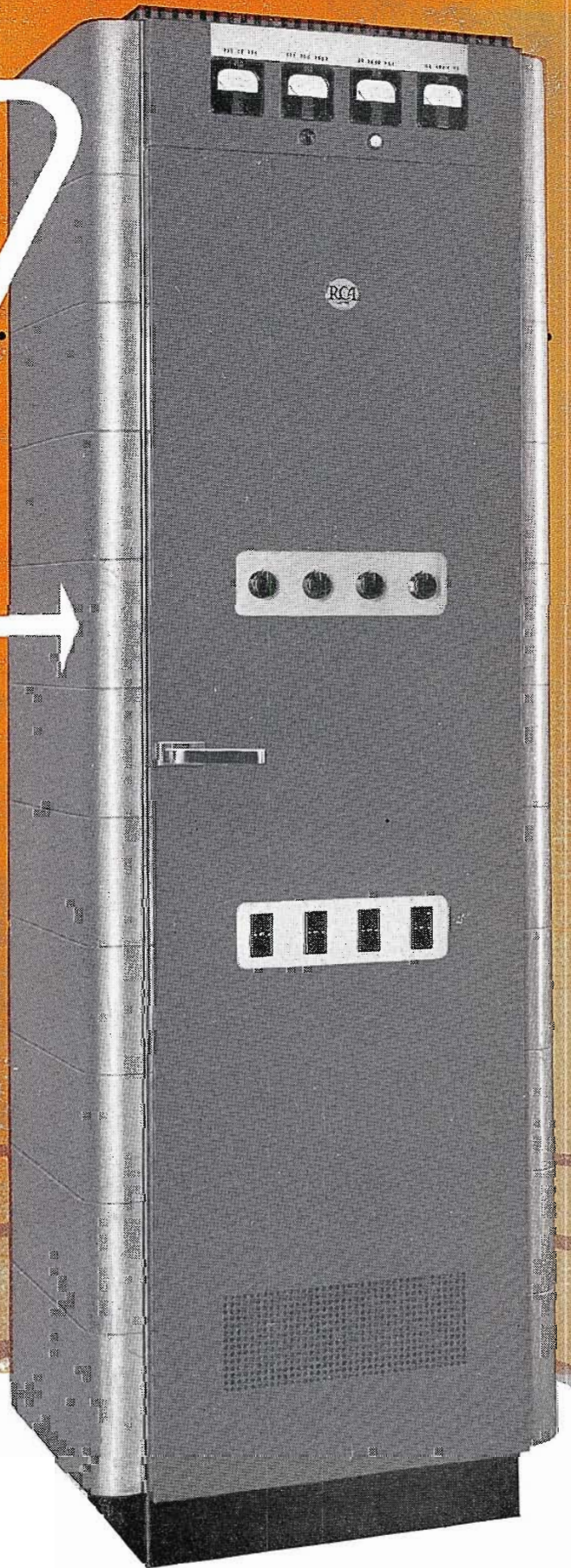

RCA
Type BTA-250M
250-Watt AM Transmitter

\$ SMALLER SIZE
—Same size as an audio rack

\$ TAKES LESS POWER
1000 watts, approximately, unmodulated

...an all-new 250-watt AM transmitter

A new concept in operating efficiency... a major advancement in plant economy

\$ BETTER FREQUENCY STABILITY
—maximum deviation, ± 5 cycles per second

**\$ NO NEUTRALIZATION
REQUIRED**

\$ FEWER TUBE TYPES
—only 3 types to stock

\$ HIGHER FIDELITY
30 to 10,000 cps. Does not exceed
2% distortion at 95% modulation

\$ FEWER TUBES (lower tube costs)
—uses only 10 tubes

Get the complete facts about this revolutionary new 250-watt AM transmitter from your RCA Broadcast Sales Engineer. Or write Dept. RCA Engineering Products, Camden, New Jersey.



BROADCAST EQUIPMENT
RADIO CORPORATION of AMERICA
ENGINEERING PRODUCTS DEPARTMENT, CAMDEN, N.J.

in Canada: RCA VICTOR Company Limited, Montreal

FCC AUTHORIZES STUDIO-TRANSMITTER LINK FOR AM, FM AND TV BROADCAST STATIONS

By R. J. NEWMAN

RCA Engineering Products Department, Camden, N. J.

Recently the FCC formally adopted the proposed modifications to the rules governing Broadcast STL (Studio Transmitter Link) stations. STL's may now be used on AM, FM, and TV (sound channel) broadcast stations, whether or not wire line facilities are available. A few pertinent excerpts from the modifications, fully covered in FCC Release No. 53467, Docket No. 9058, and Release No. 54523, Docket No. 9363, are presented in this article.

Studio-Transmitter Link equipment provides the ideal interconnecting medium between studio and transmitter sites of broadcast stations where telephone lines are not available, or where the terrain is very rugged and the installation of land lines costly. It might also be advantageous in those locations where the land lines are

established but take a long circuitous route and involve two or more common carriers. There are several features which place the STL in a preferred position as means of interconnecting studio and transmitter:

1. Uniform and consistent quality of response.
2. Requires less maintenance and attention.
3. Less costly than high quality wire lines for long distances.
4. Places the control of all broadcast facilities under licensee.
5. Provides emergency service in case failure on land lines.

Since STL is a point-to-point function, the path over which the signal must travel should be carefully studied. Its service range is dependent upon: (1) Terrain

characteristics (free space line of sight); (2) Propagation conditions; (3) Type and length of transmission line used; (4) Type and size of antenna system.

The range chart indicates that with 350 feet for RG-17/U transmission line and the standard antenna using a 48-inch reflector, a 24 mile service range can be expected. The high gain antenna and 72-inch reflector increase this range to a distance determined by local conditions and the installation.

The RCA Type BTL-1A STL equipment is a complete Studio-Transmitter Link System. It provides STL facilities for AM, FM, or TV services since it is designed to operate in the 890-952 mc band. Basically, it provides a unidirectional program channel. By multiplexing, a two-way

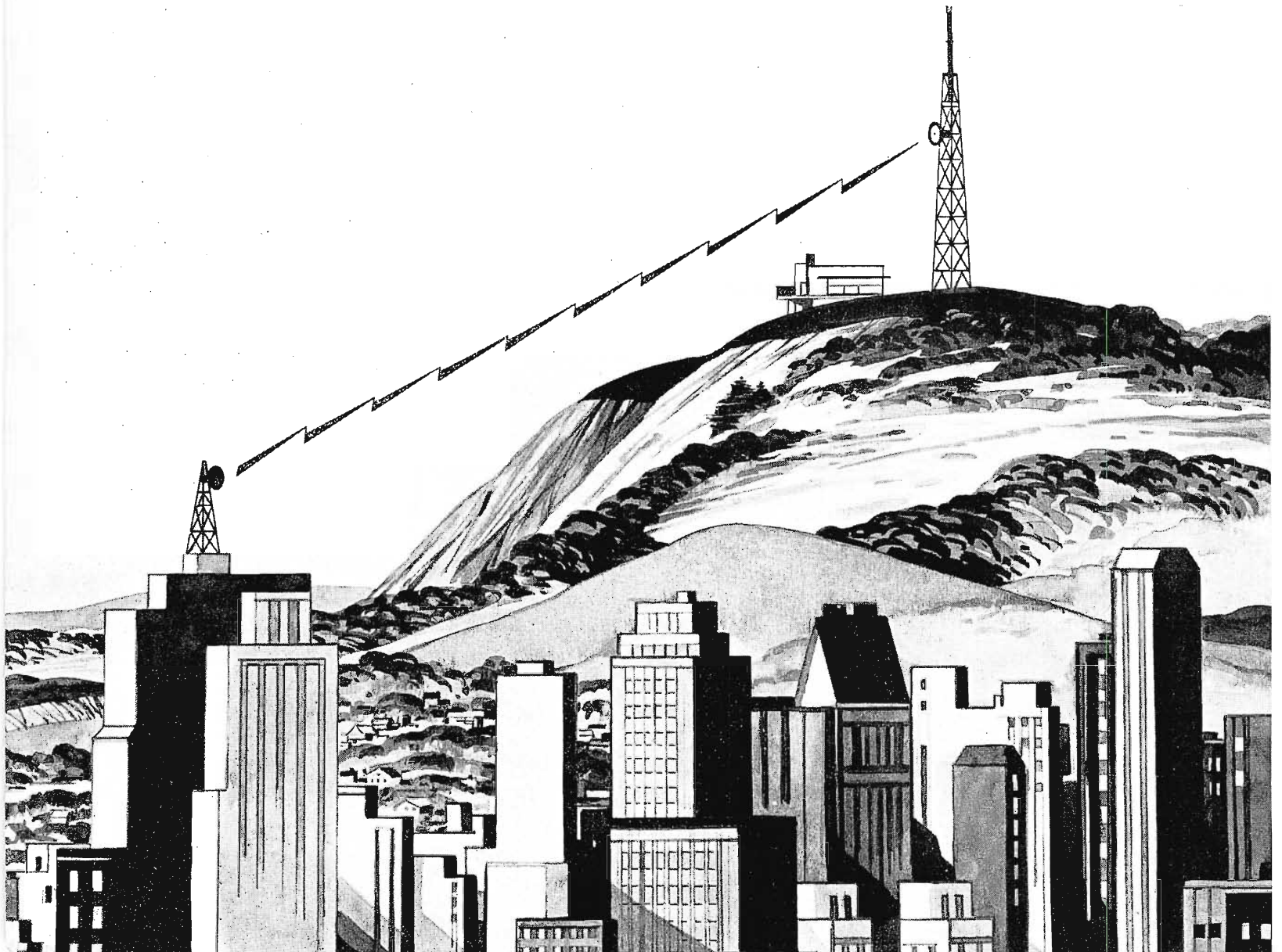

message service could be provided. Message service facilities can also be conveniently obtained through use of the RCA Mobile Communications Equipment. This latter method has the added flexibility in that it is completely independent of the program STL. Equipment of this type is licensed to operate in the groups of frequencies specified under Part 4 of FCC Rules and Regulations, Subpart D, "Rules Governing Remote Pickup Broadcast Station."

The BTL-1A studio link as it would be installed to supply a high quality program channel consists of a transmitter, receiver, and two 48-inch parabolic reflector type antennas. Block Diagram Fig. 3 indicates the relative position of the system components.

The unique transmitter design includes a modified version of the very popular RCA Direct FM exciter unit supplied in all RCA FM and TV transmitters. The output of approximately 50 mc requires only one stage of doubling followed by two stages of tripling to produce the carrier frequency. An air-cooled 4X150A power tetrode is used as the final tripler in the power amplifier. By employing conventional tuning circuits and standard tubes, a transmitter with these important features was obtained:

- (1) Highest dependability and stability.
- (2) Simplified operation and maintenance.
- (3) Low tube and replacement costs.

The transmitter is furnished in a BR-84 cabinet rack which may be aligned with the racks holding the audio equipment and located in the studio or master control room.

A crystal controlled double superhetrodyne-type of receiver is supplied for the receiving end of this STL link. Furnished with a self-contained power supply and contained in a 19-inch chassis, it requires only 12½-inch panel space. It can be mounted in the BR-84 cabinet rack which houses the terminal equipment located in the transmitter control room.

Both the transmitting and receiving antenna use a ½ wave dipole and a 48-inch standard parabolic reflector, each providing a gain of 17 db. When greater coverage is desired, 72-inch reflectors may be secured. Either air or solid dielectric transmission line may be used to feed the antennas. The length of line needed will be the deciding factor on which type is best suited.

By referring to the typical service range chart, Fig. 4, specifications for reflector diameter and type of transmission line required may be quickly determined. It is

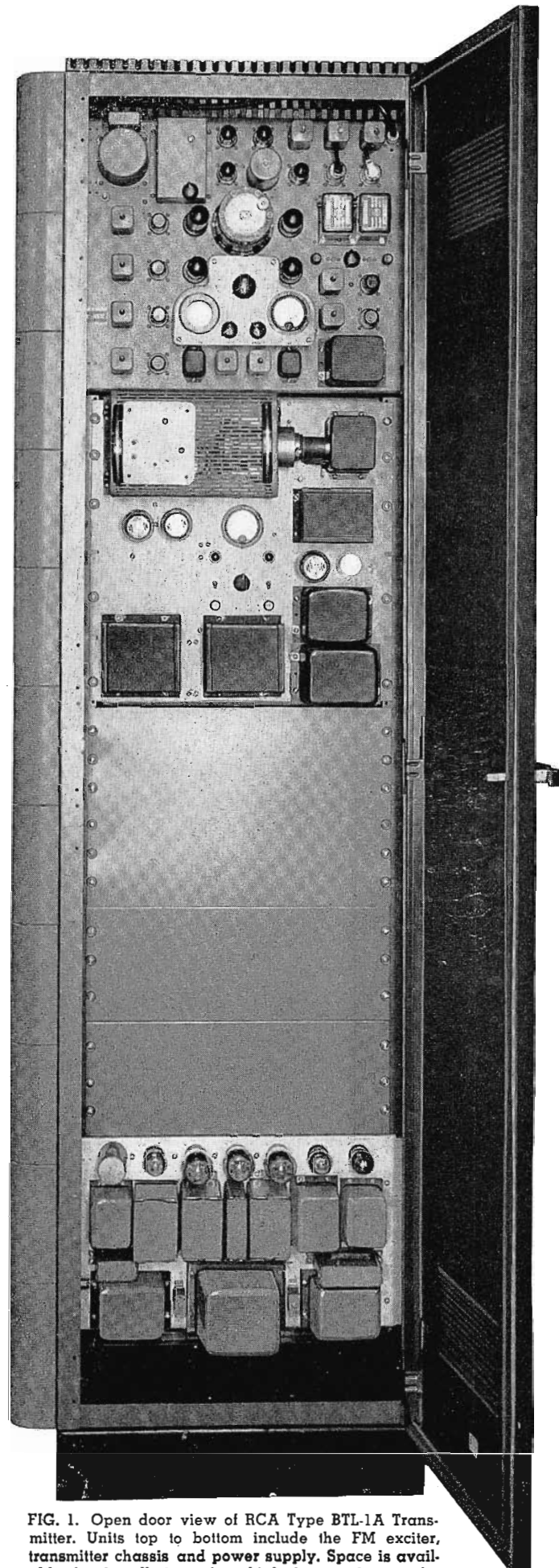

FIG. 1. Open door view of RCA Type BTL-1A Transmitter. Units top to bottom include the FM exciter, transmitter chassis and power supply. Space is available for installation of multiplexing equipment for message service or separate communications link.

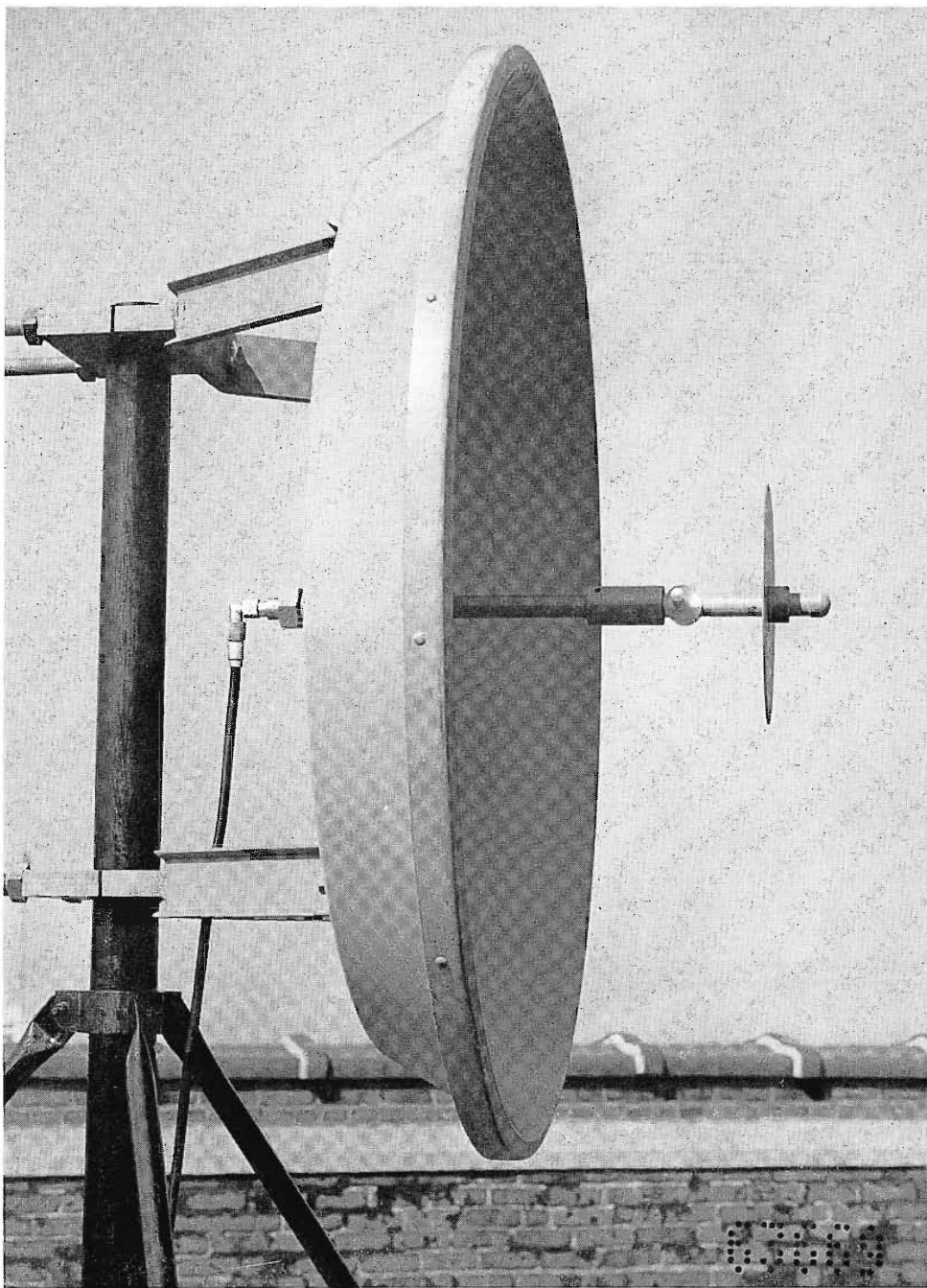

FIG. 2. Typical 48-inch parabolic reflector and antenna assembly. The antenna is fed by RG-17/U transmission line.

important to include all transmission line at both the transmitter and receiver location while using this chart.

Excerpts from FCC Authorization

Major changes have been made to Part 4 of the Commission's "Rules Governing Experimental and Auxiliary Broadcast Services." Sub-part E, "Rules Governing Broadcast STL Stations," covers definitions, frequency allocations, administrative procedures, licensing policies, equipment and technical operation for AM and FM. A new Sub-part F, "Rules Governing Television Auxiliary Broadcast Stations," provides for (a) television pickup stations, (b) television STL station, and (c) television inter-city relay station. Section 4.603

allocates frequencies for assignment to television STL stations and television inter-city relay stations for the transmission of the sound portion only of television program material or communications thereto. Television broadcast licensees may also provide their own inter-city TV transmission service on an interim basis only until such time as adequate common carrier facilities are available. The following pertinent information has been extracted from Sub-parts E and F.

Frequency and Channels

Forty-one channels are assigned in the 890-911 mc band for TV Broadcast STL and Inter-City Relay. A TV Broadcast STL station or Inter-City Relay station

may be licensed on one of the following frequencies:

890.5 mc	896.0 mc	901.5 mc	907.0 mc
891.0 mc	896.5 mc	902.0 mc	907.5 mc
891.5 mc	897.0 mc	902.5 mc	908.0 mc
892.0 mc	897.5 mc	903.0 mc	908.5 mc
892.5 mc	898.0 mc	903.5 mc	909.0 mc
893.0 mc	898.5 mc	904.0 mc	909.5 mc
893.5 mc	899.0 mc	904.5 mc	910.0 mc
894.0 mc	899.5 mc	905.0 mc	910.5 mc
894.5 mc	900.0 mc	905.5 mc	
895.0 mc	900.5 mc	906.0 mc	
895.5 mc	901.0 mc	906.5 mc	

Twenty-nine channels are assigned in the 925-940 mc band for AM Broadcast STL. An AM broadcast STL station may be licensed on one of the following frequencies:

925.5 mc	929.5 mc	933.5 mc	937.5 mc
926.0 mc	930.0 mc	934.0 mc	938.0 mc
926.5 mc	930.5 mc	934.5 mc	938.5 mc
927.0 mc	931.0 mc	935.0 mc	939.0 mc
927.5 mc	931.5 mc	935.5 mc	939.5 mc
928.0 mc	932.0 mc	936.0 mc	
928.5 mc	932.5 mc	936.5 mc	
929.0 mc	933.0 mc	937.0 mc	

Twenty-three channels are assigned the 940-952 mc band for FM Broadcast STL. An FM broadcast STL station may be licensed on one of the following frequencies:

940.5 mc	943.5 mc	946.5 mc	949.5 mc
941.0 mc	944.0 mc	947.0 mc	950.0 mc
941.5 mc	944.5 mc	947.5 mc	950.5 mc
942.0 mc	945.0 mc	948.0 mc	951.0 mc
942.5 mc	945.5 mc	948.5 mc	951.5 mc
943.0 mc	946.0 mc	949.0 mc	

Frequencies in the 925-940 mc band may be assigned to FM Broadcast STL Stations in any area where insufficient space in that area is available in the 940-952 mc band. The reverse is not true since the 940-952 mc band is not open to AM STL stations.

Where a licensee has both AM and FM broadcast stations in the same metropolitan area, one STL may be used to serve both the AM and FM.

Remote Control Operation

Remote control operation of broadcast STL station will be permitted subject to the following conditions:

- A percentage modulation indicator or calibrated program level meter shall be provided at the operating position.
- The operator shall have off-and-on control of the power to the last radio stage.

FIG. 3. Overall block diagram of the BTL-1A STL system.

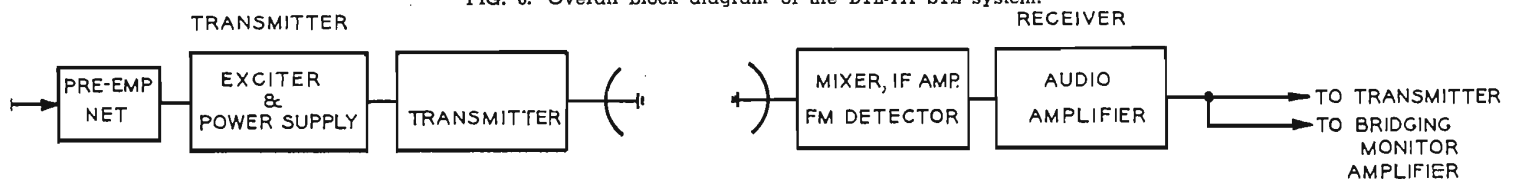

c. The transmitter shall be so installed and protected that it is not accessible to other than duly authorized persons.

For TV STL or Inter-City Relay installations, remote control operations are subject to b and c above, and, in addition:

- a. Commission must be notified at least 10 days prior to such operations and supplied with a detailed description of proposed remote control installation.
- b. The operating position shall be under the control and supervision of the licensee and shall be at the place at which a duly licensed operator responsible for the operation of the transmitter is stationed.
- c. A carrier operated device shall be provided at the operating position which shall give a continuous visual indication when the transmitter is radiating, or, in lieu thereof, a device shall be provided which will give a continuous visual indication when any transmitter control circuits have been placed in a condition to produce radiation.

Applications

Each application for a new station or change in existing station shall be specific with regard to frequency. In general, the lowest suitable frequency will be assigned which, on an engineering basis, will not cause harmful interference to other stations operating in accordance with existing frequency allocations.

More than one Broadcast STL transmitter will be licensed for use with a single broadcast station where it can be specifically shown that such is required for effective operation of a single STL circuit due to terrain, distance of transmission, etc.; or where more than one STL circuit is needed for connecting an additional studio with the transmitter, and it is shown that the nature and extent of use of such additional STL circuit will justify its authorization.

Application for Construction Permits, filing Proof of Performance, and securing a license follows the same procedure as used for AM, FM, and TV broadcast stations. FCC Form 313, "Application for Authorization in the Auxiliary Radio Broadcast Services," is used when filing for a CP. Only licensees or permittees of existing Standard AM, FM, or TV broadcast stations will be licensed to use these facilities as auxiliary to their particular AM, FM, or TV Broadcast Station.

FIG. 5 (center). Overall audio response of the BTL-1A system.

FIG. 6. BTL-1A receiver chassis (right) can be mounted in a standard BR-84 broadcast rack with input equipment, or multiplexing equipment, or with separate communications link.

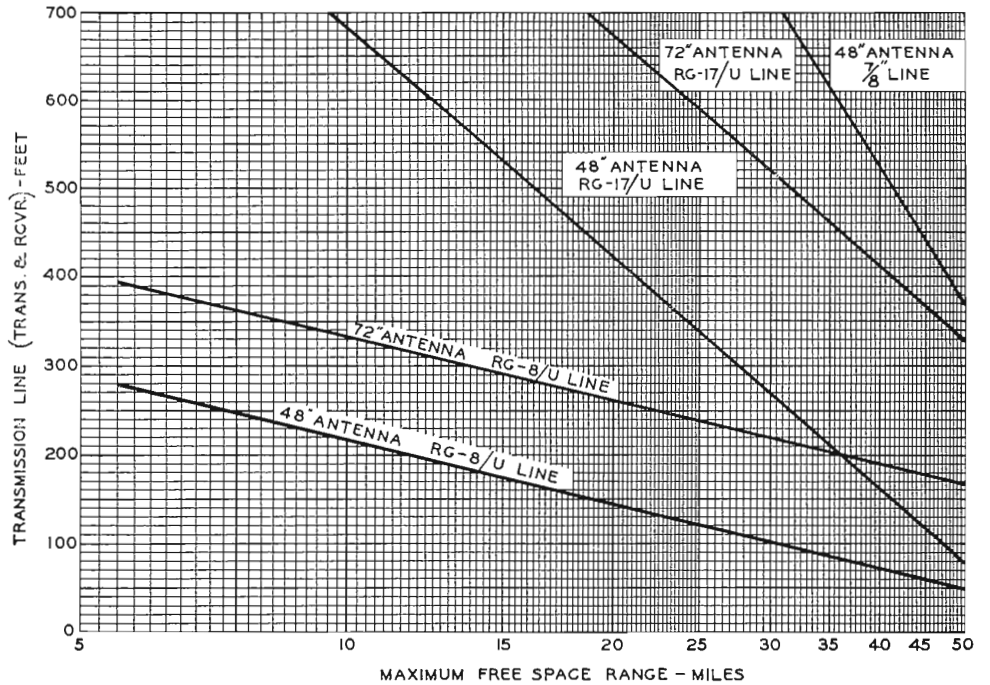
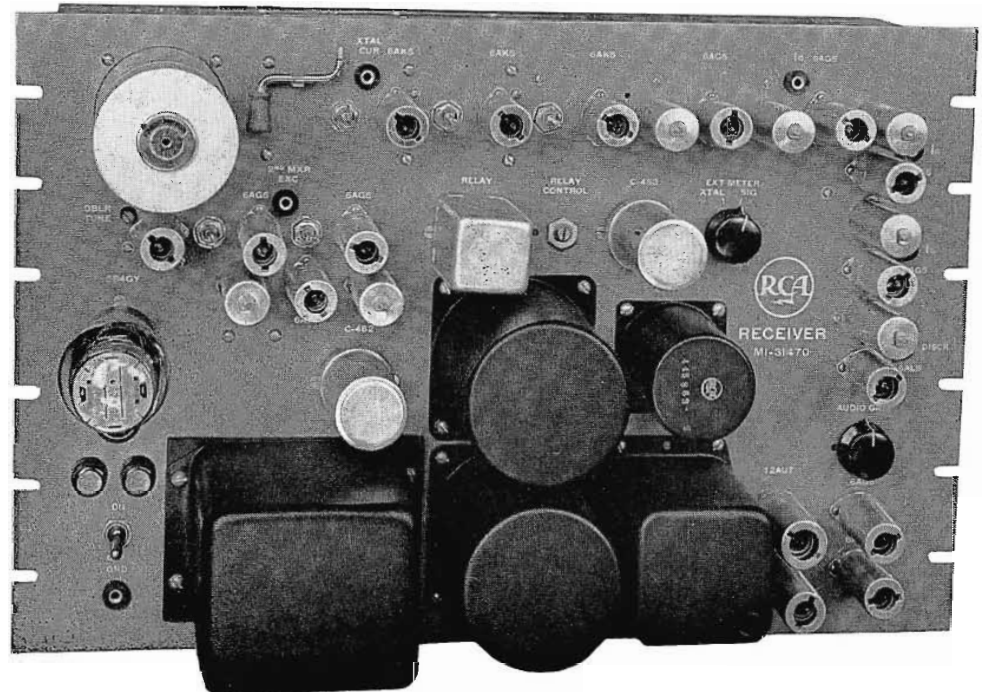
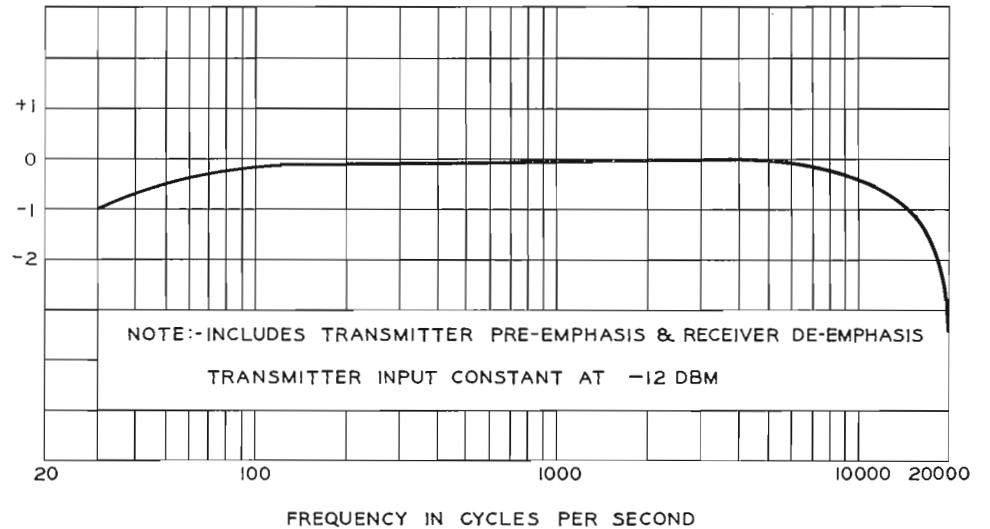

FIG. 4 (above). Chart showing typical ranges of BTL-1A link.



¡La maravilla de la

RCA

TELEVISION

es desde hoy
una magnífica
realidad
en México!

Y como la realización
de esta deslumbrante maravilla
se debe, en México,
al esfuerzo de la

Estación XHTV
CANAL 4

TELEVISION DE MEXICO, S. A.

RCA - líder mundial del Radio,
primera en música grabada
y a la vanguardia en televisión,
la expresa públicamente
sus más entusiasmados
y sinceras felicitaciones.



En la Historia
del Hogar Mexicano
empieza en este día
una Nueva Era...

Los más famosos actores del deporte
jugados sólo para usted y los tuyos...

Difíciles extraluz del Cine y del
Teatro actuaron en su propio sala...

serán, sin peligro alguno, de espec-
táculos planeados para ellos...

Además de toda clase de comodidades, toda la
familia podrá asistir a los más grandes e inter-
santes eventos de la vida política y social de la
gran urbe...

muevan el mundo llegarán
en una realidad (emé so-

RCA RCA VICTOR MEXICANA, S. A. DE C. V.
PROLONGACION MARAHU ESCUDO No. 2516

Televisão RCA

A PRIMEIRA NO MUNDO
A PRIMEIRA NA AMÉRICA DO NORTE
E AGORA A PRIMEIRA NA AMÉRICA DO SUL
com a apresentação da
PRF3-TV - Emissoras Assoc.

SÃO PAULO
América do Sul, como já
foi do Norte e no Mun-
do — a quem o pú-
blico conquistou —
arrojada conquista —
votos para que o mo-
do novo e grandio-
so seja adotado.

Uma nova era se abre para o progresso da
São Paulo e do Brasil com a apresentação da
PRF3-TV - Emissoras Associadas - São Paulo —
a primeira Estação Televisora da América do
Sul. E a RCA sempre juntamente orgulhosa em
ser, desse modo, a pioneira em Televisão na

RCA VICTOR RÁDIO
RIO DE JANEIRO - SÃO PAULO

LÍDER MUNDIAL EM RÁDIO - PRIMEIRA EM TELEVISÃO

CASSIO MUNIZ S.A.
os primeiros a lançar os
RECEPTORES DE TELEVISÃO
RCA VICTOR
Venha assistir HOJE
ao primeiro programa de Televisão
apresentado na América do Sul

Satisfazendo a intensa curiosidade pública em torno
da Televisão, Cassio Muniz S.A. instala na sua loja
de Praça da República e em outros grandes estabe-
lecimentos de S. Paulo, os afamados aparelhos re-
ceptores de Televisão RCA VICTOR, para o apresenta-
ção dos primeiros programas do postoso PRF3-TV.
Emissoras Associadas - S. Paulo.

Cassio Muniz S.A. aproveita também a
ocasião para anunciar a exposição e venda
a partir do próximo dia 14, em sua loja e
nos principais estabelecimentos de S. Paulo,
dos aparelhos receptores RCA VICTOR
que já se encontram em circulação no mundo
de Televisão Beneficiando-se das vantagens des-
cobertas praticadas nesse terreno, os
receptores RCA VICTOR apresentam recepção de imagem
construída e clara. Essa é a razão
porque em todos os países onde a tele-
visão é uma realidade, os receptores RCA
VICTOR são os preferidos pelo público.

Venha comprovar pessoalmente, as características de
que há de escolher em qualquer no mundo
os receptores RCA VICTOR

- Assista a um show de Televisão das 11 às 12 horas nos seguintes estabelecimentos:
- CASSIO MUNIZ S.A. - Praça da República, 309
 - CASA ANGLICANA - Rua do Ouvidor, 111
 - IMPAZ - Rua do Ouvidor, 111
 - EXPANSÃO - Rua do Ouvidor, 111
 - CASA CHRYSLER - Rua do Ouvidor, 111
 - RÁDIO AMÉRICA S.A. - Rua do Ouvidor, 111
 - RAI MODELO - Rua do Ouvidor, 111
 - ELECTROLUMINA S.A. - Rua do Ouvidor, 111
 - REAR, RUEBROCK S.A. - Rua do Ouvidor, 111
 - CASA UNIVERSAL - Rua do Ouvidor, 111
 - HERBIA S.A. - Rua do Ouvidor, 111
 - MILAR CLIPPEN - Rua do Ouvidor, 111
 - CASA PIRELLI - Rua do Ouvidor, 111
 - CASA PALMIRA - Rua do Ouvidor, 111
 - MODAS A EXPOZICAO BRAZ - Rua do Ouvidor, 111
 - COGELAC RAR - Rua do Ouvidor, 111
 - CAPÉ DA BE - Rua do Ouvidor, 111
 - CONFEITARIA PALACIO LTDA. - Rua do Ouvidor, 111
 - FALCIO DE DISCO - Rua do Ouvidor, 111
 - CONFEITARIA DA BE - Rua do Ouvidor, 111
 - DIARIAS ASSOCIADO - Rua do Ouvidor, 111

DISTRIBUIDORES
CASSIO MUNIZ S.A.
IMPORTAÇÃO E COMÉRCIO
Praça da República, 309 - São Paulo
FOLHA DA MANHÃ, quarta-feira, 16 de...

TELEVISION RCA VICTOR DESDE 1923

... y estos son algunos de los hechos que lo demuestran.
RCA VICTOR es "LA PRIMERA EN TELEVISION"



"LA PRUEBA DEL MILLON"
Al igual que en radio y sonidos, también en televisión RCA Victor produce los hechos que hacen la historia.
En televisión... también RCA Victor hace la historia!

RCA VICTOR
IMPERSA EN TODA LA LINEA

HUMARA y LASTRA S. en C.
Teléfono 405 y 407
Teléfono M-5650 y M-5659

RCA TELEVISION..NEW LINK FOR THE AMERICAS

RCA is First in Mexico, in Cuba, and in Brazil

by **MEADE BRUNET**, Vice President
Radio Corporation of America
and Managing Director of
RCA International Division



Less than a year ago Television meant little to the average *Señora* in Mexico City. The typical *Cubano* in Havana, and *Paulista* at home in Sao Paulo, talked and read about television, but television in the home was a dream. Today, Television—specifically RCA Television—is on the minds and lips of millions of our neighbors in Latin America.

Television is unfolding in Mexico, Brazil, and Cuba. The technical and creative talents of Latin America are now joined for the further development of the video art.

In the space of a few months, four RCA Television stations have been shipped, installed and placed in operation by a skillful team—the RCA International Division; the RCA Service Company; RCA associated companies in Latin America; and our RCA Distributors. In addition to the four RCA-equipped stations in operation, others are being planned or are in the negotiations stage.

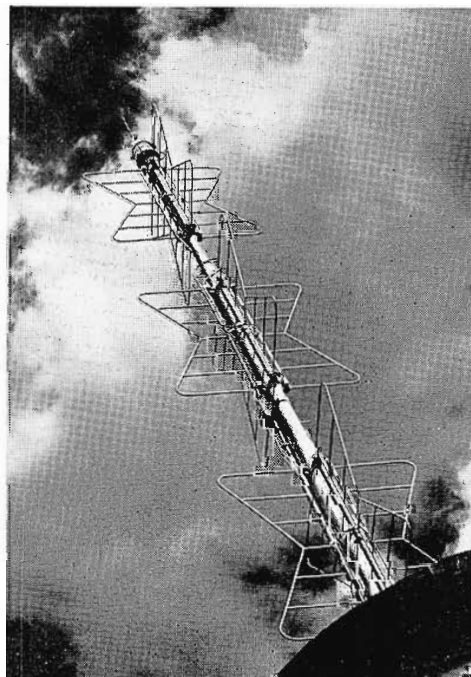

FIG. 1. Closeup of XHTV's Super Turnstile Antenna which tops Mexico City's skyline.

The two RCA-equipped stations in Havana—CMQ-TV, and Union Radio Television, go on the air shortly with television programs daily. Station XHTV carries regular schedules from Mexico City. PRF3-TV transmits regularly from atop the State Bank Building in Sao Paulo, Brazil. These stations all operate on RCA 5 kilowatt transmitters, and are backed by a full complement of RCA Cameras, Microphones, and other RCA Studio Equipment besides RCA Control and Monitoring Equipment.

At the same time the regular station equipment was shipped, RCA distributors in Brazil, Mexico, and Cuba began receiving the latest RCA Victor television receivers. Thousands of 16-inch and 19-inch RCA Victor table-model and console TV receivers will soon be in service in these countries. RCA associate companies can and will develop facilities for assembling television receivers locally.

It is a great satisfaction for RCA, its companies and distributors, to see televi-



FIG. 2 (above). Scene of a bullfight as seen on the master monitor screen in XHTV's Mobile Unit.

sion at work in Latin America. It is destined to be a strong cultural, educational force, and entertainment medium.

Latin American program fare is varied—and thoughtfully balanced. Today, all the gala pomp and pageantry of the bullfights held at the Plaza Mexico Arena is transmitted on regular schedules by Mexico City's new television station. The baseball fan in Havana is enthusiastic about his "Beisbol" idol's performance on the screen of his RCA Victor receiver. The Sao Paulo soccer fan or *afeiçado* looks forward to action-packed living room close-ups, thanks to RCA Television.

In all countries, news of the day and special events are of top TV interest. In Mexico City and Cuba there are fronton or jai-alai matches. President Miguel Aleman's speech at the opening of the recent joint session of the Mexican Congress was televised and carried, as its first public service program, by Station XHTV. Good music, much of it performed by well known RCA Victor artists, is another important aspect of Latin American life and comes in for its full share of the television spotlight.

Latin American television staffs are well trained, competent, and come into this new field with well rounded backgrounds of related radio experience. All owners, man-

FIG. 3 (below). XHTV's Mobile Field Truck shown covering a "Remote Pickup" from the Aztec Golf Club.





FIG. 4 (above). In this view one of XHTV's Field Cameras is focused on a dramatic bullfight scene to show the bullfighter being gored by the bull.

FIG. 5 (below). Another scene showing an XHTV Remote Pickup of the popular "Jai-Alai" sport.



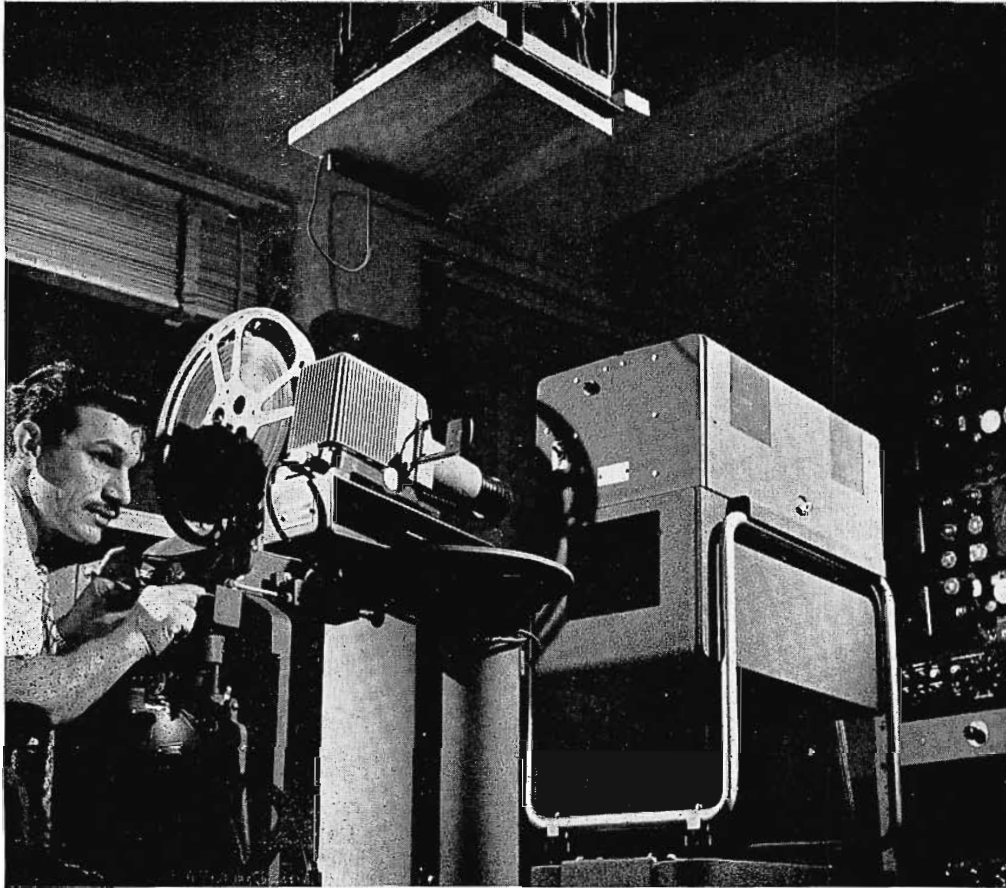

FIG. 6 (above). Closeup view showing part of the XHTV Film Projection Room facilities.

agers, and station engineers of the new stations in Cuba, Brazil and Mexico have closely observed video at work in the United States. The National Broadcasting Company, RCA Victor Division, and the RCA Service Company have cooperated in an intensified, comprehensive coverage of Station Operation, Program Production, and Television-Receiver Servicing for our clients.

In addition to the management and technical executives, some stations have sent writers, announcers and program directors to study the NBC television methods in New York City.

The promise of inter-country television programs has been heightened by the advent of these new stations. Discussions are already under way for the exchange of specially prepared kinescope films among Brazil, Mexico, Cuba and the United States. The proximity of Cuba and Mexico to the United States presents the promise of a not-too-distant-future programming schedule of live shows.

Television has opened a whole new world of education to the Americas. National leaders, scholars, Ministers of Education and Public Welfare are studying the



FIG. 7. View of video operators adjusting XHTV's Camera Control Units. Visible at extreme left is part of the TS-10A Studio Camera equipment.

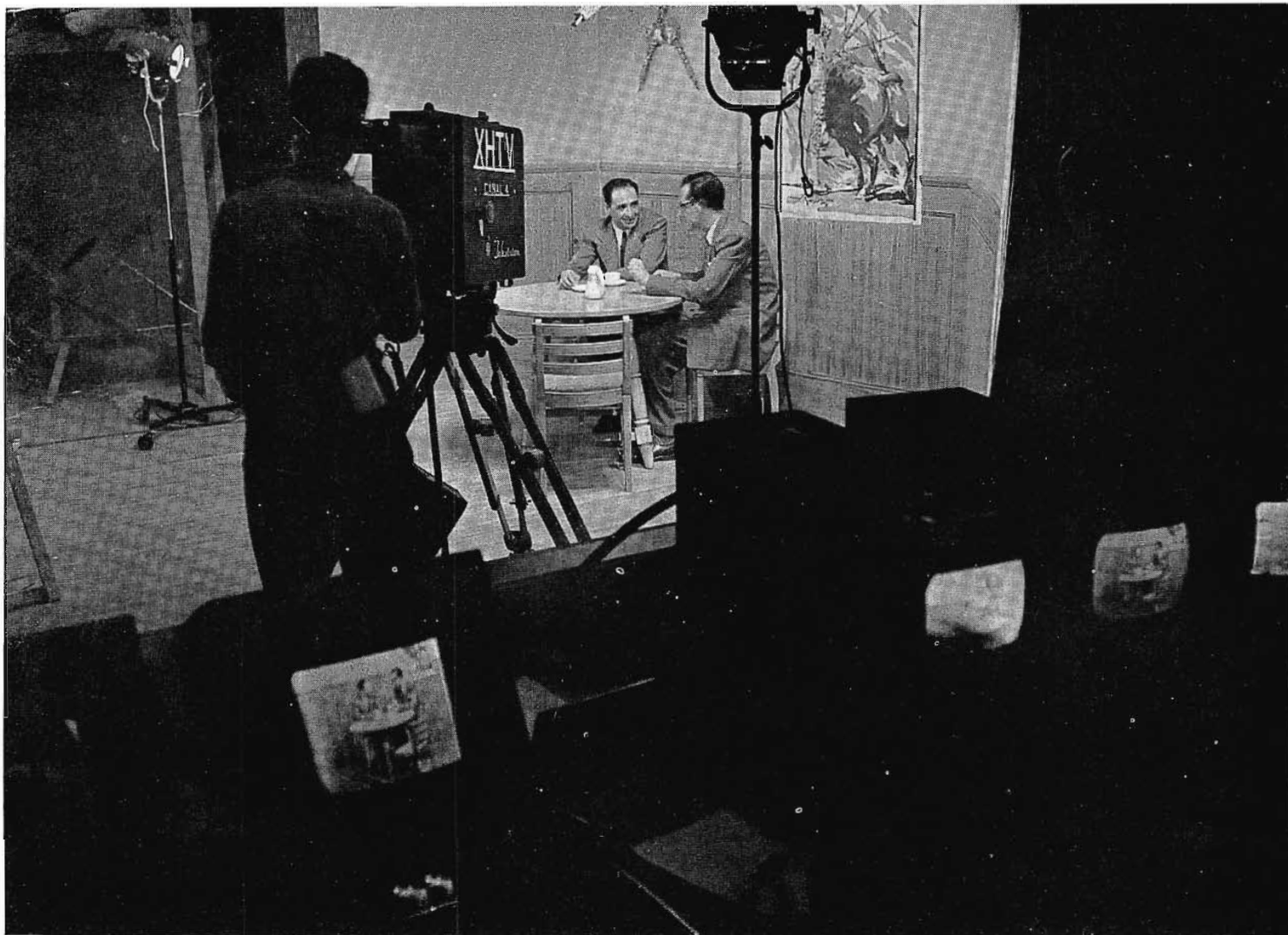

FIG. 8 (above). View of "Bullfighter Interview Show" in an XHTV studio. Also visible are Monitors and Studio Control equipment.

FIG. 9 (below). Closeup of XHTV studio action showing the telecast of a Mexican stage show.





FIG. 10 (above). View of XHTV's three-section Super Turnstile Antenna which is located atop the National Lottery Building.

tremendous cultural and educational benefits of the new medium. The Government of Mexico is making plans to install television receivers in schools as parts of its educational program.

The appearance of the new Television Stations in Latin America highlights once again the rapid march of progress of our Inter-American neighbors. In a message to the new RCA equipped stations in Brazil and Mexico, Edward G. Miller, Jr., Assistant Secretary of State for American Republic Affairs stated: "It is a matter of history that the countries of this hemisphere move forward hand in hand, for the betterment of the human race. . . . I salute the initiative and leadership of those who have brought into being this significant institution of popular entertainment and information. . . ."

Mexico's TV Station Facilities

The RCA-equipped station in Mexico City, XHTV, is owned and operated by Television de Mexico, S. A., an enterprise of Romulo O'Farril, Sr. Señor O'Farril is also the publisher of the newspaper NOVEDADES and owner of Mexico City's AM Station XEX. The station's first test pattern was broadcast on July 16, 1950. Formal inauguration and subsequent regularly scheduled programs took place September 1.

Station XHTV is located in the 20-story National Lottery Building, highest struc-

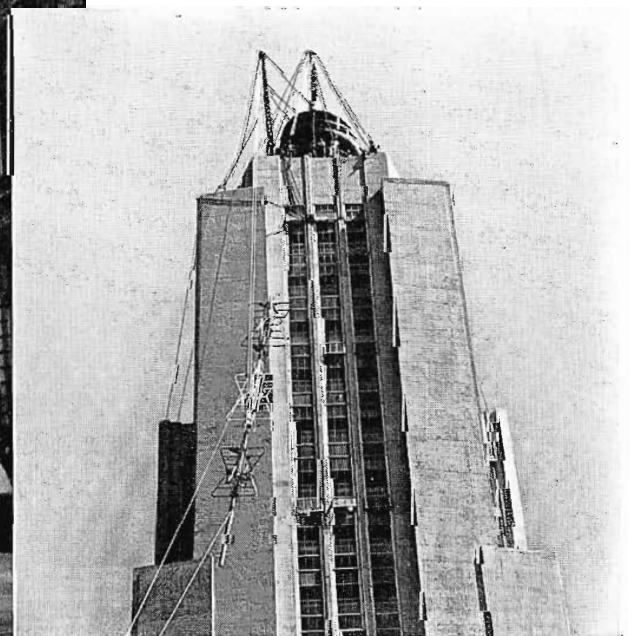

FIG. 11 (above). The Super Turnstile Antenna on its way up the building during installation.

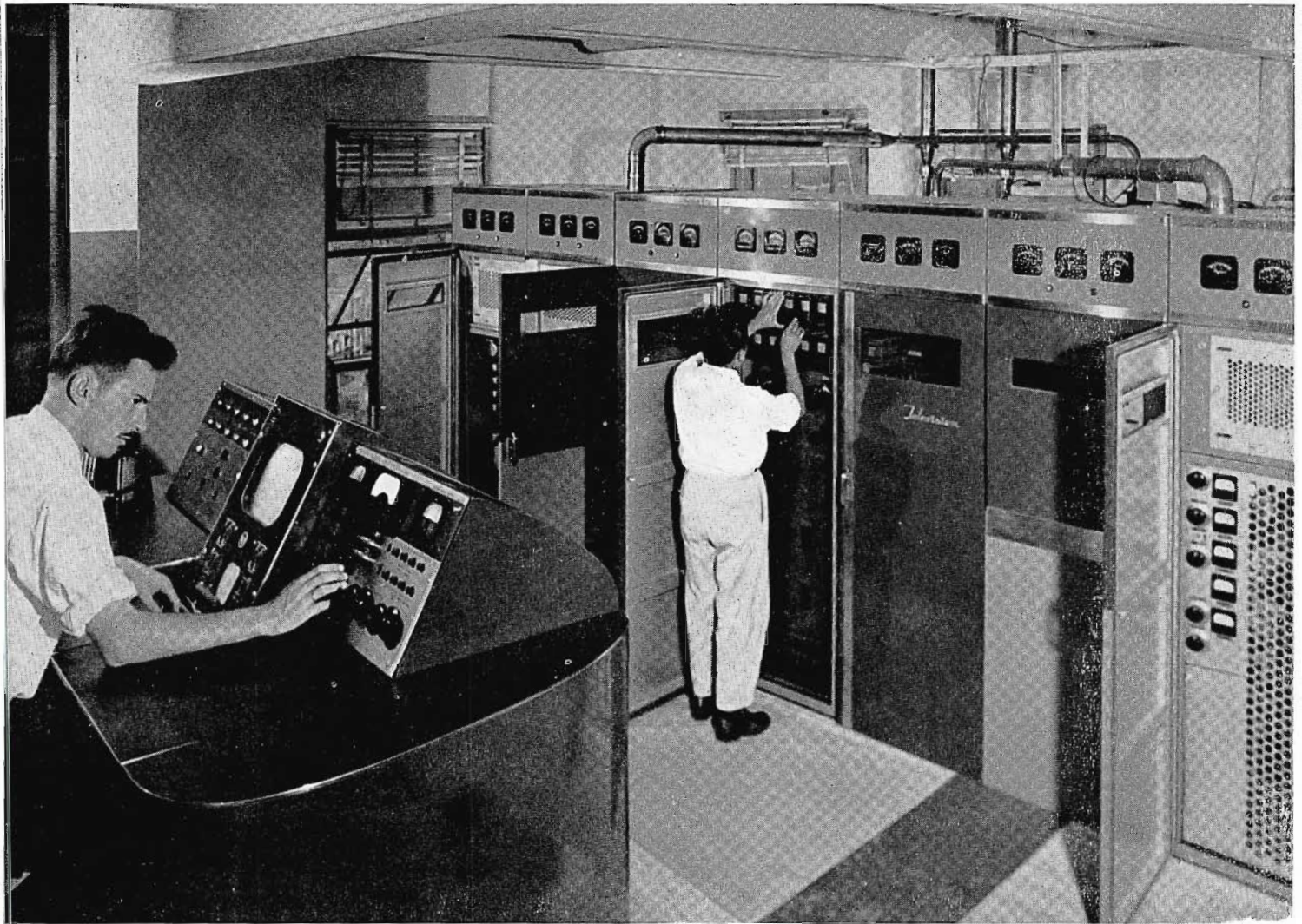

FIG. 12 (above). View of XHTV's 5-kw Television Transmitter (RCA TT-5A) and Transmitter Master Control Console.

ture in the Mexican capital, and is equipped with a 5-kilowatt transmitter, antenna, and associated studio and mobile pickup equipment supplied entirely by RCA.

The facilities of XHTV are similar to those of TV stations in the United States. Two floors of the modern building house the studios, control room, sponsor's booth, rehearsal room, dressing rooms, transmitter, service shop and offices of the new station. Television concerts and theatrical productions will originate in a large ground floor auditorium.

In spite of the fact that Mexico City's power supply is of 50 cycles, XHTV is operating on Channel 4 in exact accordance with American Television standards of 525 lines and 60 fields. RCA Victor Mexicana, S. A. de C. V., RCA's associated company in Mexico, handled the XHTV installation with the O'Farril engineers.

RCA's distributor of home instruments in Mexico, Corporacion Nacional Dis-



FIG. 13. Photo taken during XHTV inaugural ceremonies. Lic. Augustin Garcia Lopez, Secretary of Communications and Public Works, is at the microphone. At the left is Romulo O'Farril, Sr.



FIG. 14. Video demonstration shown in Sao Paulo, Brazil at inauguration of the Museum of Modern Art. Dr. Assis Chateaubriand, President of the Diarios and Emissaros Associadas introducing the guest speaker, the former Minister of Education, Mr. Clement Marioni.

FIG. 15. View of PRF3-TV's 5-kw RCA Transmitter and Control Console as installed at Sao Paulo Bank Building.

tribuidora, S. A., put a large TELEVISION sign on its headquarters a year ago—a prophecy now fulfilled.

Brazil's TV Station Facilities

Sao Paulo's PRF3-TV, headed by Dr. Assis Chateaubriand, Director-General of Emissoras Associadas, televised its first test pattern on July 24, 1950. This was preceded on July 5 by a closed circuit demonstration attended by President Eurico Dutra, U. S. Ambassador Herschel Johnson, Nelson D. Rockefeller and an audience of 500 representatives of government, industry and society. The official station opening took place on September 18, 1950 when a regular schedule of programs was inaugurated.

From planning to operation, Station PRF3-TV is a good example of the close cooperation and teamwork for which RCA is famous. The RCA International Division in New York and RCA's associated

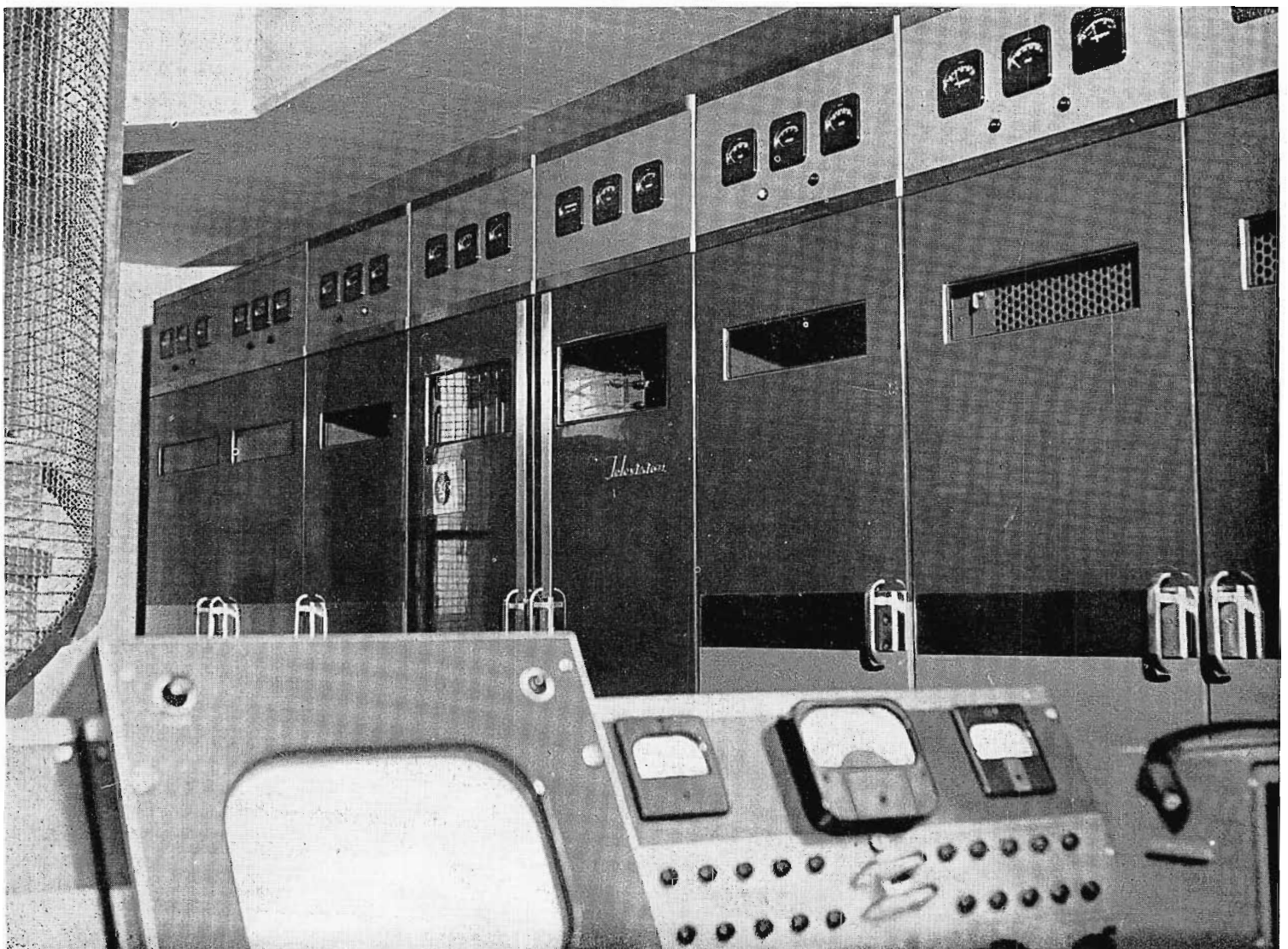



FIG. 16 (above). Photo taken at Sao Paulo Municipal Stadium during telecast of an important football match between S. E. Palmeras and Sao Paulo Football Club.

FIG. 17 (below). RCA Video demonstration in lobby of Mr. Chateaubriand's new building at Sao Paulo, Brazil. TV receivers were located at various points to provide scenes of Friar Mojica singing.





company in Brazil, RCA Victor Radio, S. A., worked hand in hand with Cassio Muniz and Co., the RCA distributor in Sao Paulo, and the well prepared Emissoras Associadas staff which supervised the installation and inaugural operations.

PRF3-TV equipment includes: A standard type RCA TT-5A (5 KW) Transmitter; a three bay turnstile antenna; studio equipment; remote pickup equipment and an RCA Type TJ-50A Mobile Unit.

The antenna is located 520 feet above street level atop Sao Paulo's highest building, and is capable of radiating 20 KW of power. Studios are located in Sumare, a Sao Paulo suburb. Provisions have been made for RCA microwave transmitting equipment between the studio, outdoor mobile pickup unit, and the main transmitter. Station PRF3-TV operates on U. S. channel 3 (60-66 mc). It operates on United States television standards of 525 lines and 60 fields.

Cuba's TV Stations

CMQ-TV operates from the huge \$2,000,000 facilities of Radio Centro, Cuba's Radio City. This station is under the management of Goar Mestre. Television equipment in CMQ-TV was supplied by RCA.

Union Radio TV is housed in a mansion which has been especially re-converted for Television. The RCA station equipment includes an RCA 5-kilowatt transmitter, remote pickup equipment, microwave relay equipment, television cameras, film projectors, mobile truck and other related broadcast equipment.

As this article goes to press, another complete RCA television station will be erected in Havana by the Telenews Company, Alonso, S. A. This will bring the total of RCA-equipped Television Stations in Cuba to three.

FIG. 18 (above). View of PRF3-TV's antenna installed atop the State Bank Building in Sao Paulo.

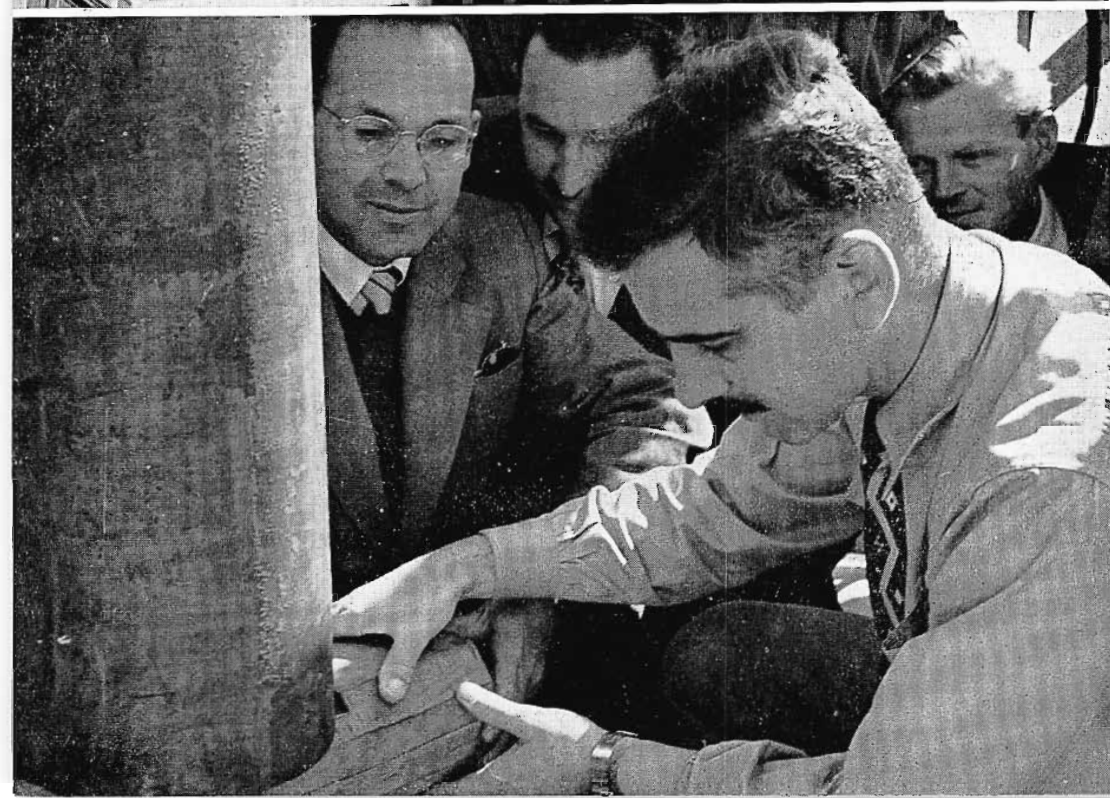

FIG. 19 (at left). Mr. W. Obermuller, RCA Engineer, shown inspecting the position of the television tower at its base support.



FIG. 20 (above). View of wooden superstructure constructed at top of the Sao Paulo State Bank Building during antenna installation.



FIG. 21 (above). In this view workmen are shown constructing a suitable base for "seating" the tower.

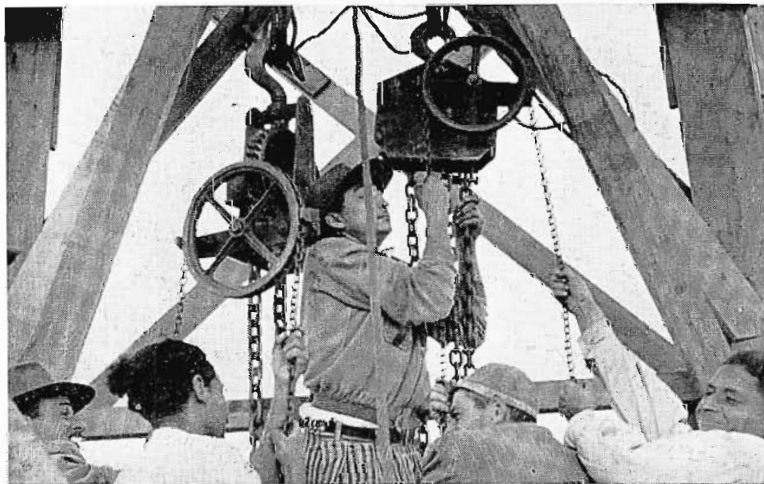
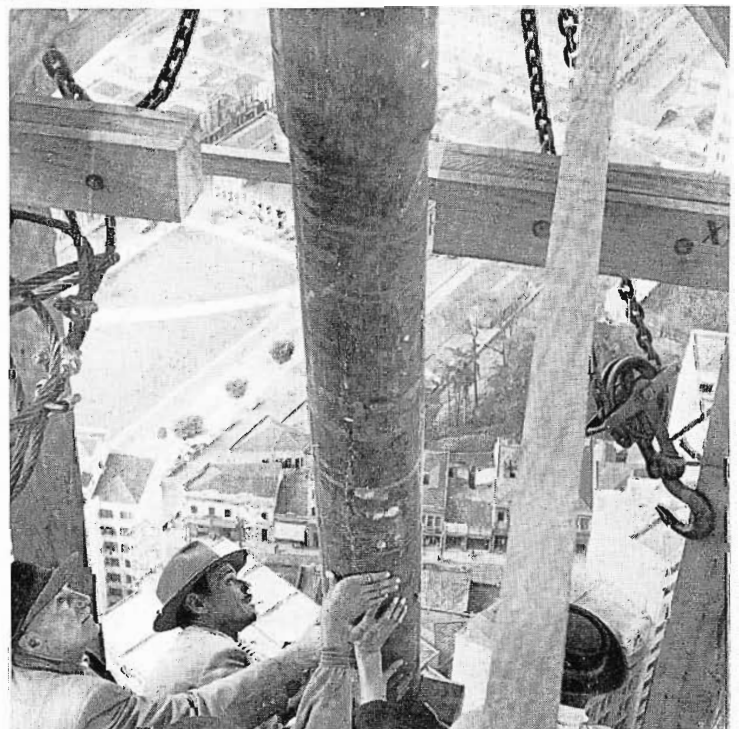
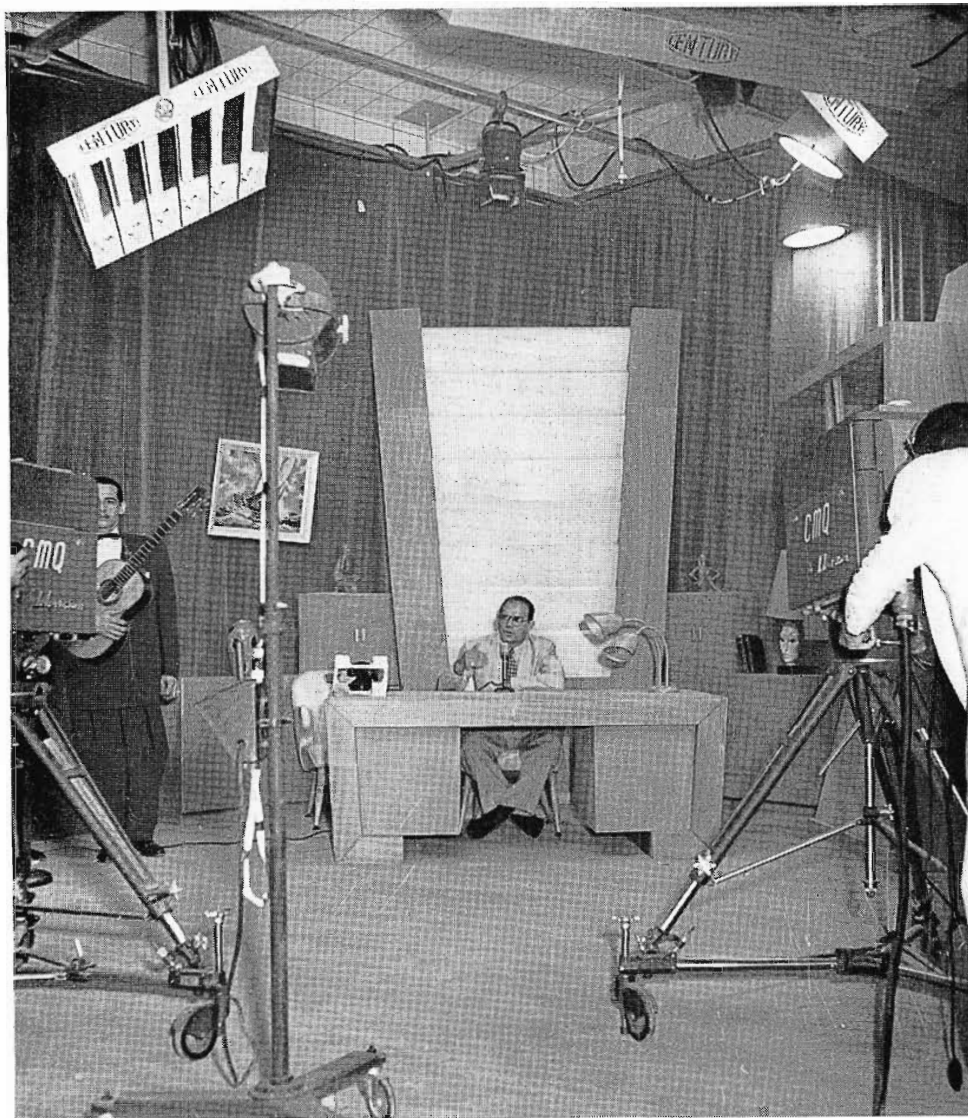

FIG. 23 (at left). Construction workers at the top of the Sao Paulo State Bank Building are shown during antenna "lifting" process.

FIG. 22 (below). In this view riggers are shown attaching cables preparatory to lifting the television antenna from the ground floor.

FIG. 24 (below). In this view, the PRF3-TV antenna is shown being lifted to the top of the tower on the Sao Paulo State Bank Building.





This new station will be under the direction and management of Manual Alonso, President of the Telenews Company.

The plans call for immediate construction and installation of the 5-KW Television Station and associated equipment, and the transmission of regularly scheduled programs in early 1951.

All stations are located in Havana, and will serve as key stations for proposed Television networks now being planned for the country. Since Cuba is located in the tropical hurricane zone, special reinforcement has been provided for each station's 200-foot transmitter antenna.

Television in Cuba operates on standards adopted by the United States. Consequently, no unusual transmission or receiving difficulties are presented. Installation of the Cuban stations was made by RCA Service Company engineers in cooperation with each station's engineers and technicians. Humara y Lastra have been the Cuban distributors of RCA Victor products for more than forty years.

◀ FIG. 25. Señor Goar Mestre, Owner and Director of the huge Circuito CMQ network of Cuba, is shown "on-camera" during the pre-inauguration broadcasts of Station CMQ-TV in Havana.



◀ FIG. 26. The CMQ Mobile Unit shown in front of the Rockefeller Plaza during its trip to "Circuito CMQ", Havana, Cuba.

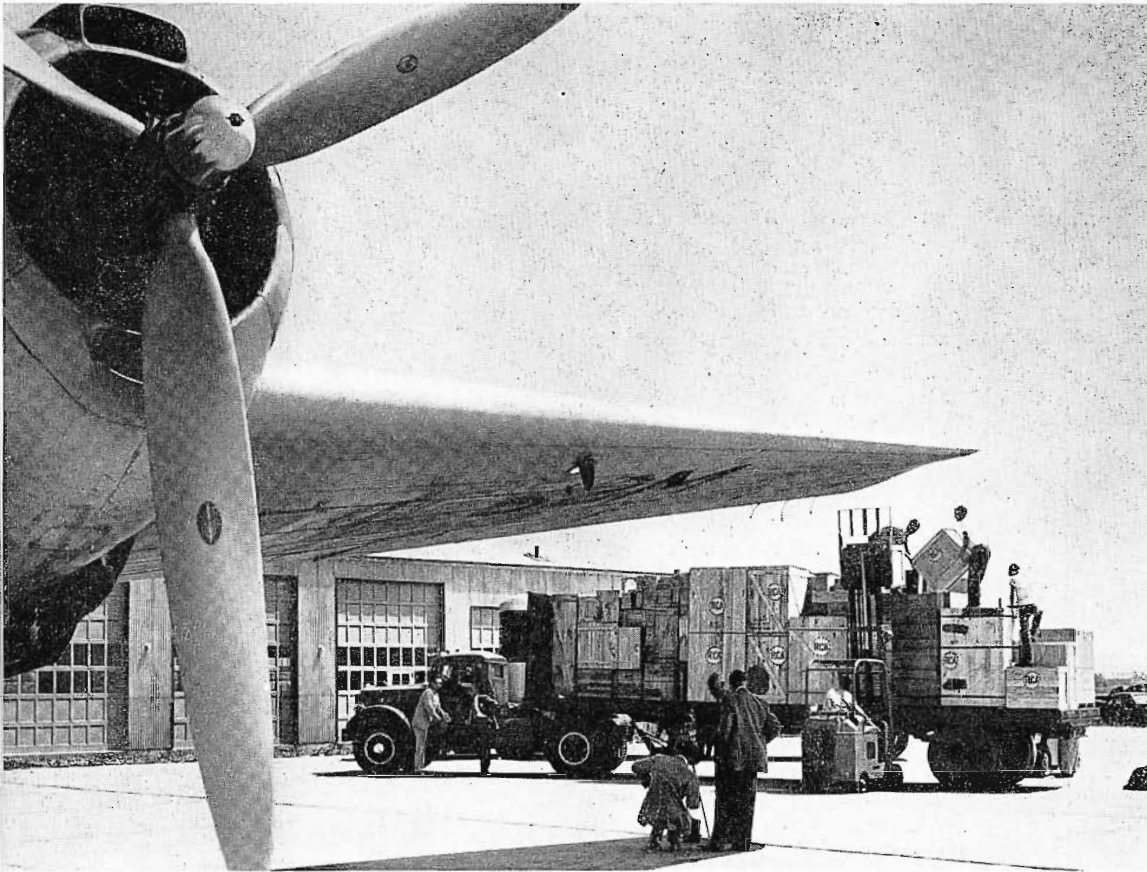

FIG. 27. Part of the complete RCA television equipment is shown at Philadelphia International Airport prior to loading aboard National Airlines plane bound for Union Radio, Havana. This was the first such shipment in television history.



FIG. 28. President Dr. Carlos Prío Socarrás of Cuba, and his daughter, little Maria Antoneta, shown with Union Radio TV executives at formal inauguration of that station's broadcast schedule.



KSD AND KSD-TV, ST. LOUIS

Both KSD and KSD-TV, the St. Louis Post-Dispatch stations, are pioneers in their respective fields. KSD received its AM license on March 14, 1922, and was the first licensed commercial broadcasting station in St. Louis. KSD-TV was the first completely post-war equipped television station in the entire United States and has been operating commercially since February 8, 1947. KSD-TV began its experimental operations in September 1946, although plans for the station were begun ten years earlier.

Before and during KSD-TV's experimental telecasting, RCA and KSD-TV

by
GEORGE M. BURBACH
General Manager

engineers worked side by side, practicably exemplifying the spirit of cooperation which has prevailed between KSD and RCA for more than two decades. Since October, 1949, the station's revenue has been consistently greater than its operating expenses. At the present time, KSD-TV is telecasting 85 to 90 hours of programming per week.

The operating experience gained in KSD's integrated broadcasting layout em-

phasizes the potentials which can be realized in using existing structures. The St. Louis Post-Dispatch broadcast setup includes both AM and TV. The AM transmitter is situated in East St. Louis and the TV transmitter is installed on the roof of the Post-Dispatch building. All studios and associated equipment are located entirely within the newspaper's former publishing plant. This includes all equipment for TV broadcasting plus four AM studios with related control rooms. Studio facilities are located on the ground floor and station offices and other facilities on the mezzanine and second floor directly above.

The overall facilities employed to telecast these programs, and those used to broadcast the programs of KSD, are described in the accompanying articles by Mr. J. E. Risk, Chief Engineer, and Mr. C. R. Yarger, KSD Operations Supervisor.



Mr. George M. Burbach, General Manager of KSD and KSD-TV.

FIG. 1 (at left). This view from KSD's marble business lobby shows the paneled reception room. Herculite glass doors are located ahead of a short run of steps leading to the studios on the first floor. The station's business offices are on the mezzanine at the head of the stairs.

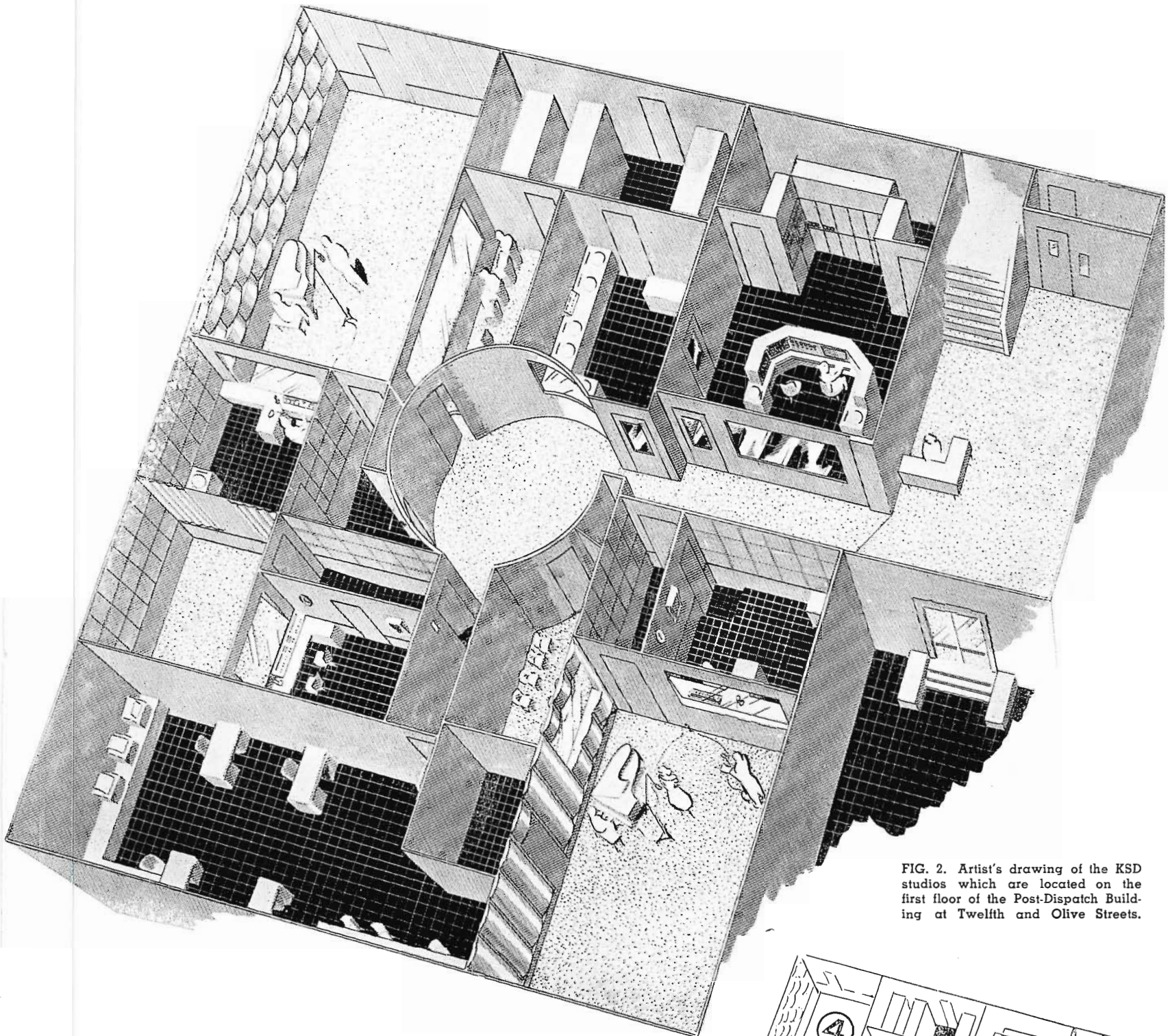

FIG. 2. Artist's drawing of the KSD studios which are located on the first floor of the Post-Dispatch Building at Twelfth and Olive Streets.

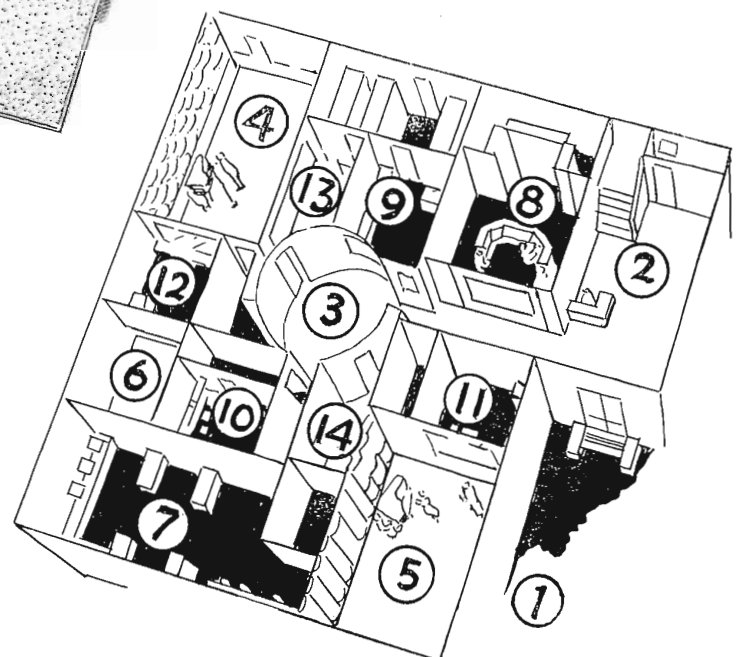

FIG. 3. Key to artist's sketch shown above. The numbers in the key sketch indicate the location of studios, control room and so forth. No. 1—Entrance Lobby; No. 2—Reception Room; No. 3—Rotunda; No. 4—Studio A; No. 5—Studio B; No. 6—Studio C; No. 7—KSD Newsroom; No. 8—Master Control Room; No. 9—Recording Room; Nos. 10, 11 and 12—Studio Control Rooms. Nos. 13 and 14—Observation Rooms for watching performances in the studios. (The artist's sketch and layout diagram shown here may prove useful in referring to Mr. Yarger's description of AM Studios on the pages following.)

KSD'S AM FACILITIES

Entrance to the station's facilities is through a walnut-paneled lobby which serves as a control point for traffic to the ground floor studios and to the station's offices and other facilities on the mezzanine and second floor directly above. Three of the four studios as well as the transcription room, news room and master control room have been grouped around a 15-foot rotunda. This affords members of the station's staff ready access to all facilities.

Every device for effective broadcasting control has been engineered into the KSD

by
C. R. YARGER
KSD Operations Supervisor

studios. Perforated asbestos cement panels have been used on three sides and the ceiling of the studios, a plastered wall with basket weave pattern being on the fourth for balanced acoustical control. The plastered wainscoting and trim have been painted to harmonize with the other wall surfaces. The entire studio and new office

area has been air conditioned with an aggregate cooling capacity of 100 tons. The station began operation with all new studios, transmitter building and equipment from microphone to antenna on November 22, 1948.

The technical facilities of KSD consist of 4 control rooms, a recording room and a master control room. Each studio control room contains an RCA 76-C consolette, a single section sound turret (MI-14909), two 76-D turntables, LC-1A loud speaker and 88-A talk-back microphones.

FIG. 1 (below). View of the Master Control Room at the new KSD Studios showing the control console in front and nine Deluxe Audio Equipment Racks at the rear. All AM program control functions are handled from this point.





◀ FIG. 2. The KSD Recording Studio which incorporates four RCA 73-B Professional Recorders in a compact, yet efficient, arrangement of equipment. Mr. Ray Herchert shown at the Recorder Console.

FIG. 3. The unique arrangement of studios and control facilities centers about this rotunda in order to facilitate coordination of overall operations. Recording Studio can be seen through window on the left. ▶

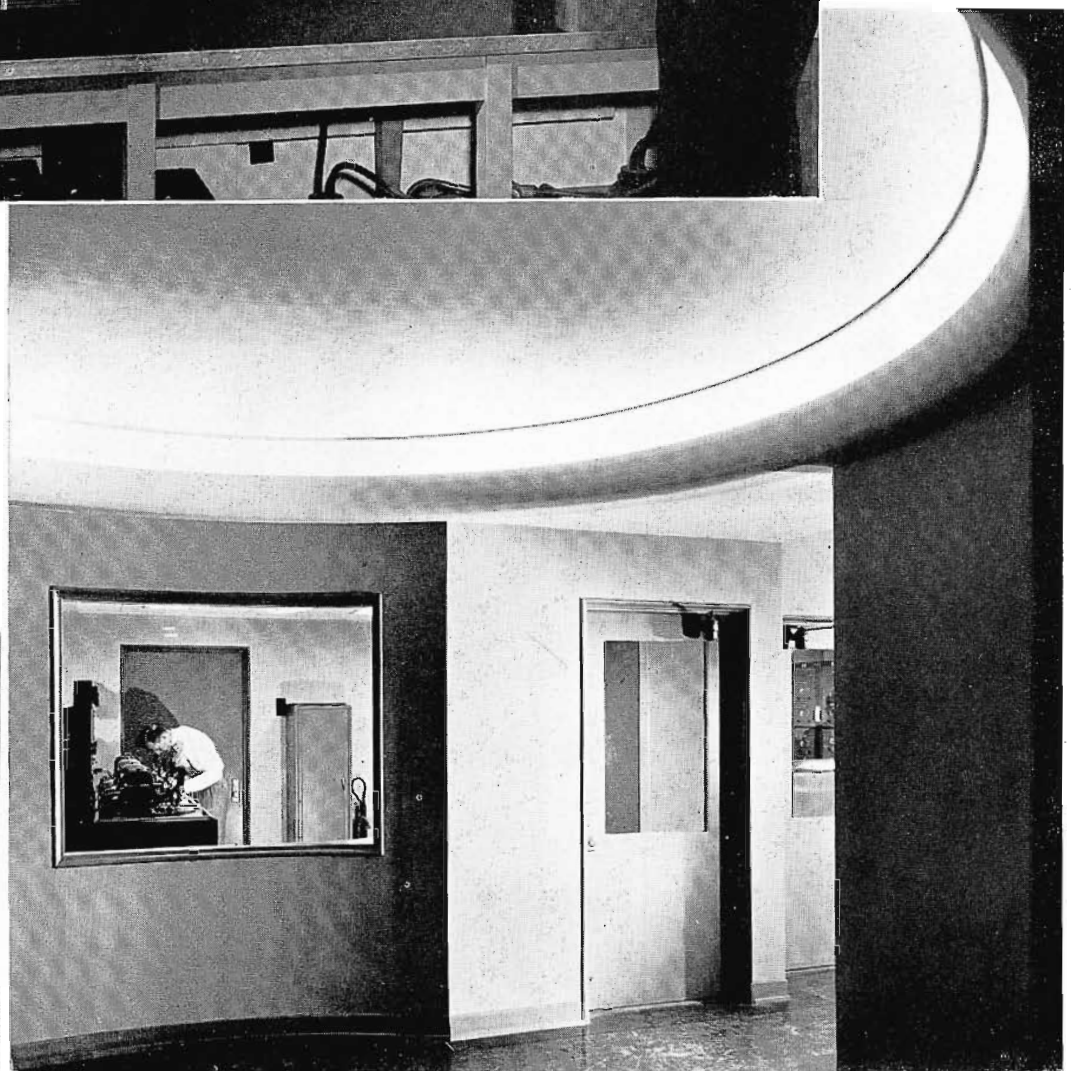

◀ Mr. C. R. Yarger, Operations Supervisor, KSD, St. Louis.



FIG. 4. View of KSD Studio "B" from the control room. Broadcast, Studio, Control and sponsor's observation facilities are in one compactly grouped area.

Three RCA 33-A jack panels are installed in the sound turret and interconnected to the 76-C consolette so that all program circuits are available for patching.

The recording room contains four RCA 73-B recorders equipped with automatic equalizers and suction equipment. Two 60-watt amplifiers are used to drive the recorders. An average of 2000 discs are used each year.

The master control room contains a control desk and nine racks of equipment. Panel One of the control desk contains ring-down circuits for twelve remote lines, four studios, plant, Chief Engineer and Telephone Company. Panel Two is used to select one of the twelve remote lines on a two-position remote mixer. It also contains gain controls for the two net and two remote amplifiers.

Panel Three contains the six outgoing channels. Included are: Preset, On Air Lights, relays and gain controls for each channel. All channels have a choice of ten inputs. The selector system contains 60 relays. Panel Four consists of four 33 jack panels, to which all the remote lines are

FIG. 5 (below). Most of the KSD newscasts, chain-break commercials and interviews go out from Studio "C", which is shown here as it appears from the control room. RCA 76-type Consolettes and LC-1A Monitoring Speakers are used in all control rooms.



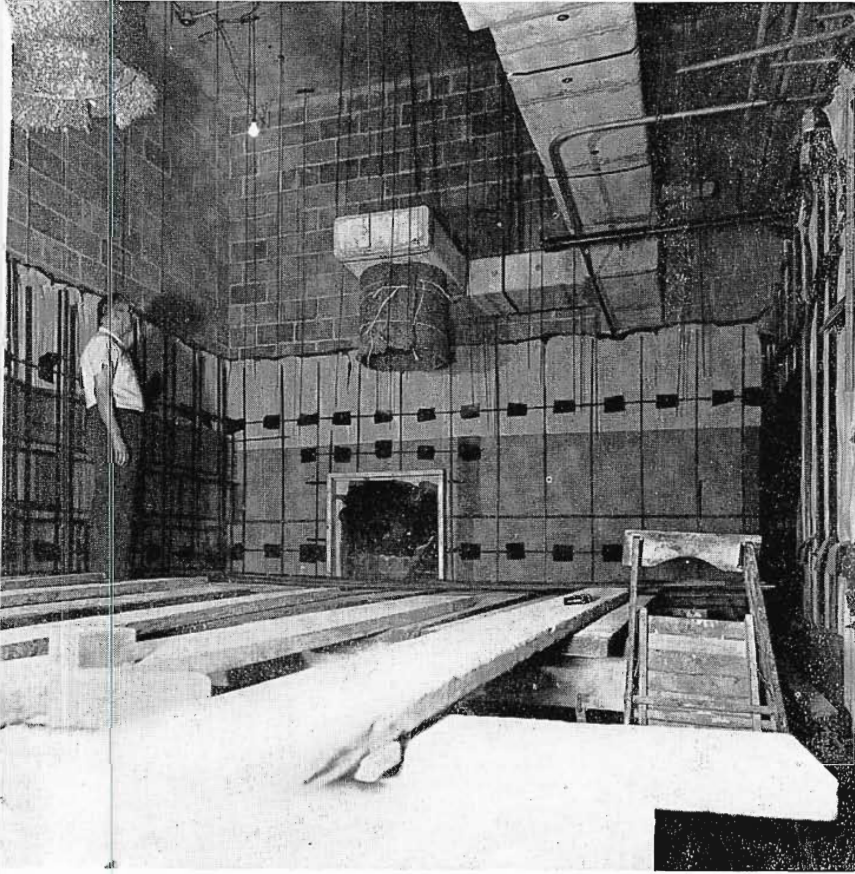

▲ FIG. 6. This photo shows how the studio ceiling is specially suspended by wires for best acoustical properties.

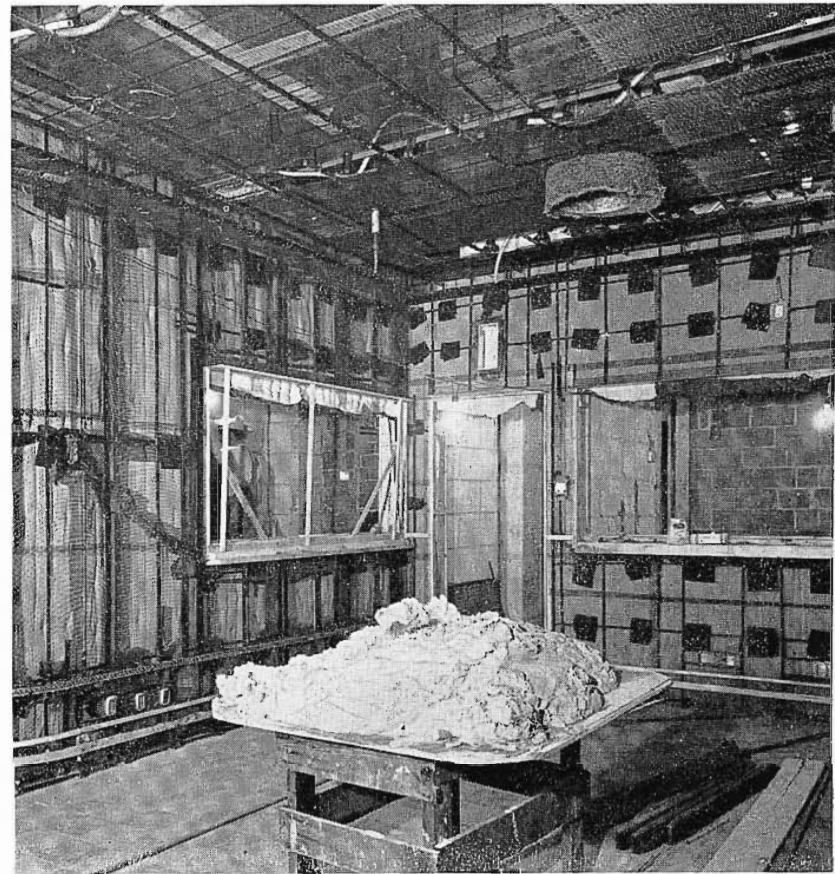

▲ FIG. 7. Perforated asbestos cement panels are used on three sides and plastered basket-weave pattern on fourth.

FIG. 8. The studio ceiling is completely surfaced with perforated transite over special acoustical material. Air-conditioning outlets and fluorescent fixtures are flush mounted.



▼ FIG. 9. A floating floor resting on cork and spring supports helps provide "room-within-room" isolation. Wainscoting and trim are painted to harmonize with the wall surfaces.

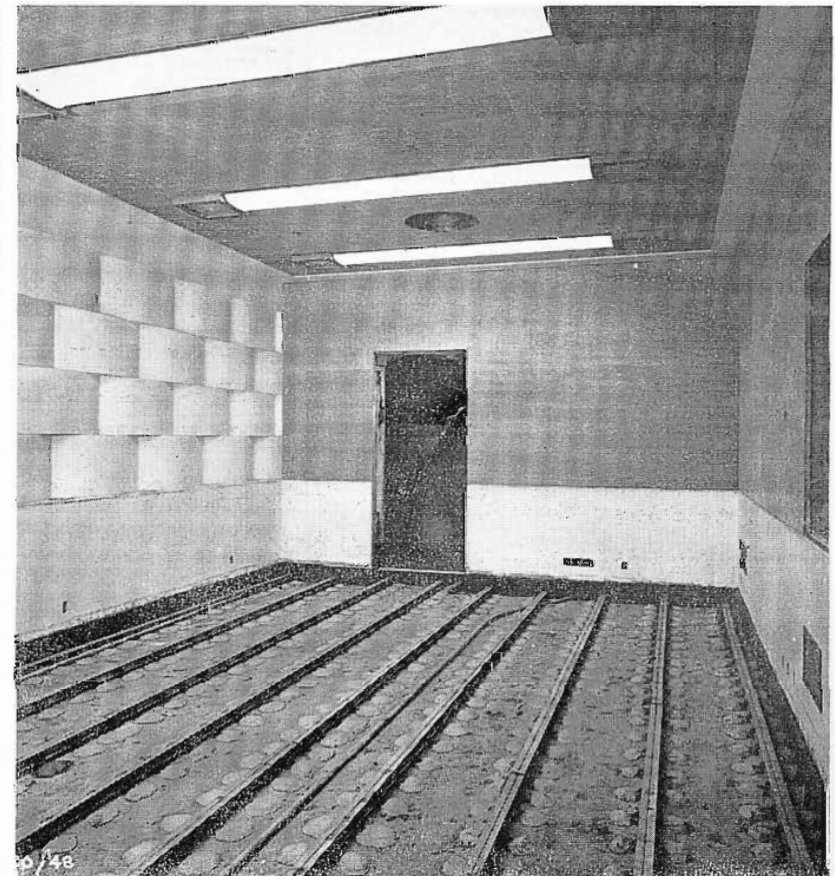



FIG. 10 (above). KSD's AM transmitter at East St. Louis is housed in this brick and stone structure, where all the facilities required for maintenance of equipment and convenience of personnel have been provided. Two towers of the four-tower KSD antenna array are shown in the background.

connected. Panel Five contains jacks for the studio and net terminations. Rack One contains two remote amplifiers, two line equalizers and jacks for twenty-four remote and private lines. A remote cue amplifier is also contained in this rack. Rack Two consists of two net amplifiers, and terminations for two net lines. All the studio lines and the studio tie-lines terminate in Rack Three. This rack also contains a house monitor amplifier. Rack Four contains the six line amplifiers for the six channels. Rack Five contains eleven bridging amplifiers for isolating the program circuits from the monitor bus. Rack Six consists of three monitor amplifiers to drive three LC-1A speakers in master control. This rack also contains a distortion meter and an audio oscillator. Rack Seven contains two twelve-volt power supplies and

nineteen stepper relays for the monitor system. Rack Eight contains five AM receivers. Rack Nine contains five FM receivers.

Throughout the building, monitor speakers have been installed which are connected through a telephone type dial to the stepper relays in Rack Seven. Twenty-one different programs may be dialed at these remote points.

On April 29, 1947, a construction permit was granted KSD for 5000 watts day and night with directional antenna for nighttime operation.

In order to obtain maximum coverage and efficiency, a 67-acre tract was selected in Madison County, Illinois, two miles north of East St. Louis near Horseshoe

Lake, and approximately four miles from our studios in the St. Louis Post-Dispatch Building, at 1111 Olive Street.

The transmitting equipment consists of an RCA BTA-5F with the necessary phasing unit plus frequency, modulation and phase monitors, control console, limiting amplifier, audio oscillator and noise and distortion meter and other speech input amplifiers.

The equipment is located in a 40 x 70 foot brick and stone structure where all facilities required for maintenance of the equipment and convenience of personnel have been provided.

All power and telephone lines are buried six feet underground from the transmitter building to the main highway, approximately 900 feet away.

Proof of performance tests were completed and on November 22, 1948, the station with all new equipment from microphone to antenna began operation.

The antenna system was designed by the A. D. Ring Company and consists of four insulated 445-foot Blow-Knox, self-supporting towers situated at the corners of a parallelogram. During the nighttime hours the four towers are utilized to produce the required pattern. During daytime, non-directional operation is effected by exciting the west radiator with the other elements insulated from ground. Rectangular sampling loops 6 x 14 feet are mounted 30 feet above the insulators. The antenna tuning equipment is located in wooden houses directly under the towers.

The ground system consists of 120 buried radials extending 450 feet from the 60-foot square ground screen under each

tower. Approximately 36 miles of No. 9 copper wire and 4000 feet of 2-inch copper strap was used. All the ground system is interconnected and brazed to heavy 2-inch copper strap.

Communications Products 72-ohm coaxial lines extend from the phasing unit to the towers.

No. 4 line $1\frac{3}{8}$ -inch diameter 880 feet.

No. 1 line $\frac{7}{8}$ -inch diameter 500 feet.

No. 3 line $\frac{7}{8}$ -inch diameter 520 feet.

No. 2 line $\frac{7}{8}$ -inch diameter 850 feet.

All sampling lines are $\frac{3}{8}$ -inch diameter and 1034 feet in length.

The necessary conduits for tower lighting and circuit controls are suspended along with the coaxial lines, 12 inches above ground, on cedar posts spaced 10 feet apart.

FIG. 11. Front view of the KSD AM transmitter (RCA BTA-5F) complete with phasing equipment. Mr. C. R. Yarger is shown at the Supervisory Console, and Mr. R. W. Cole, Transmitter Supervisor, at the transmitter.

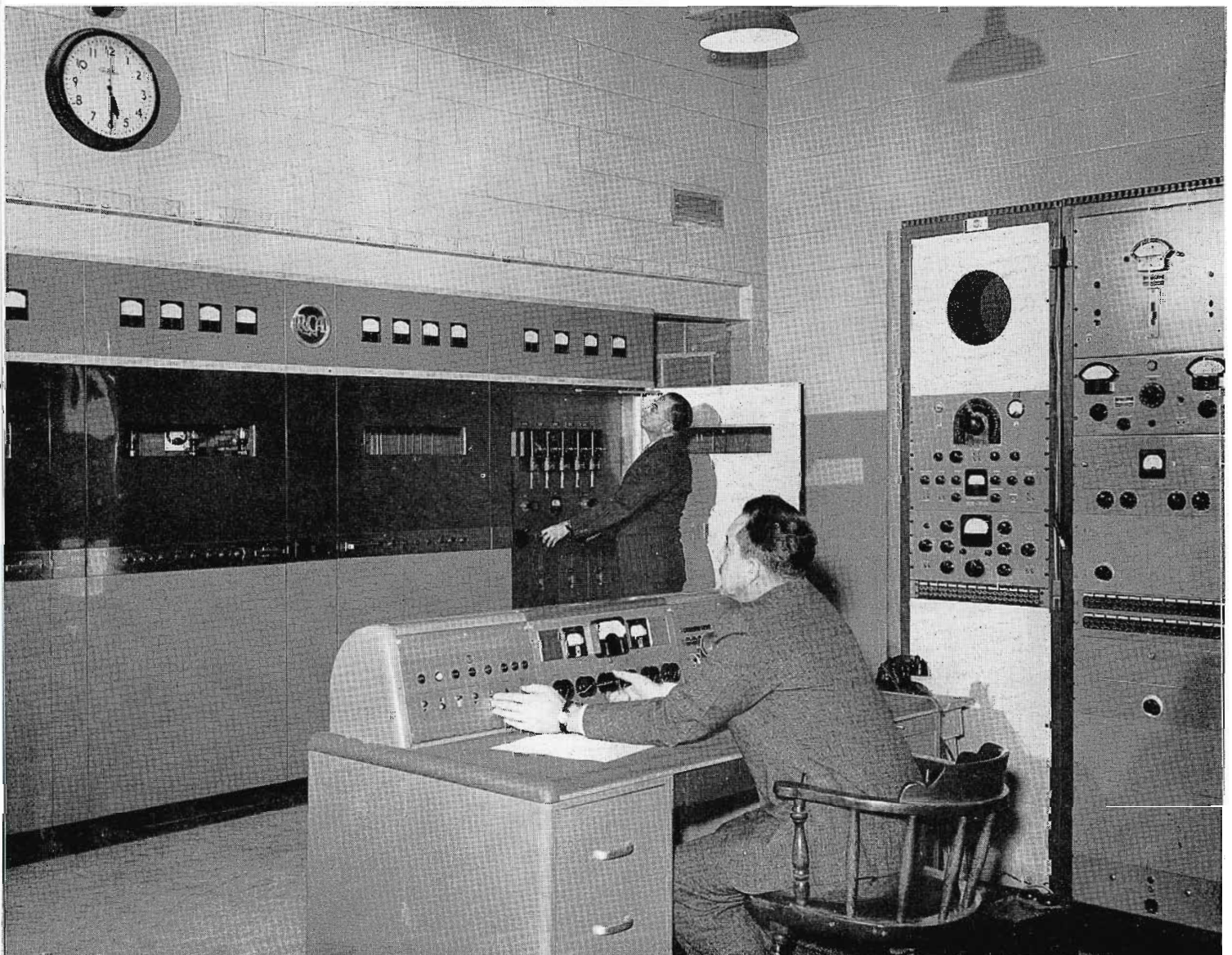

EQUIPMENT IS THE WORLD'S FINEST

Keep your RCA microphones, transcription pickups and recording heads at peak performance level.

Have your RCA microphones, transcription pickups and recording heads periodically inspected and reconditioned by the manufacturer's own repair experts. Write today for complete information.

* * *

RETURN APPARATUS CONTROL
Building 8-2

RCA SERVICE CO. INC.

A Radio Corporation of America Subsidiary
Camden, New Jersey

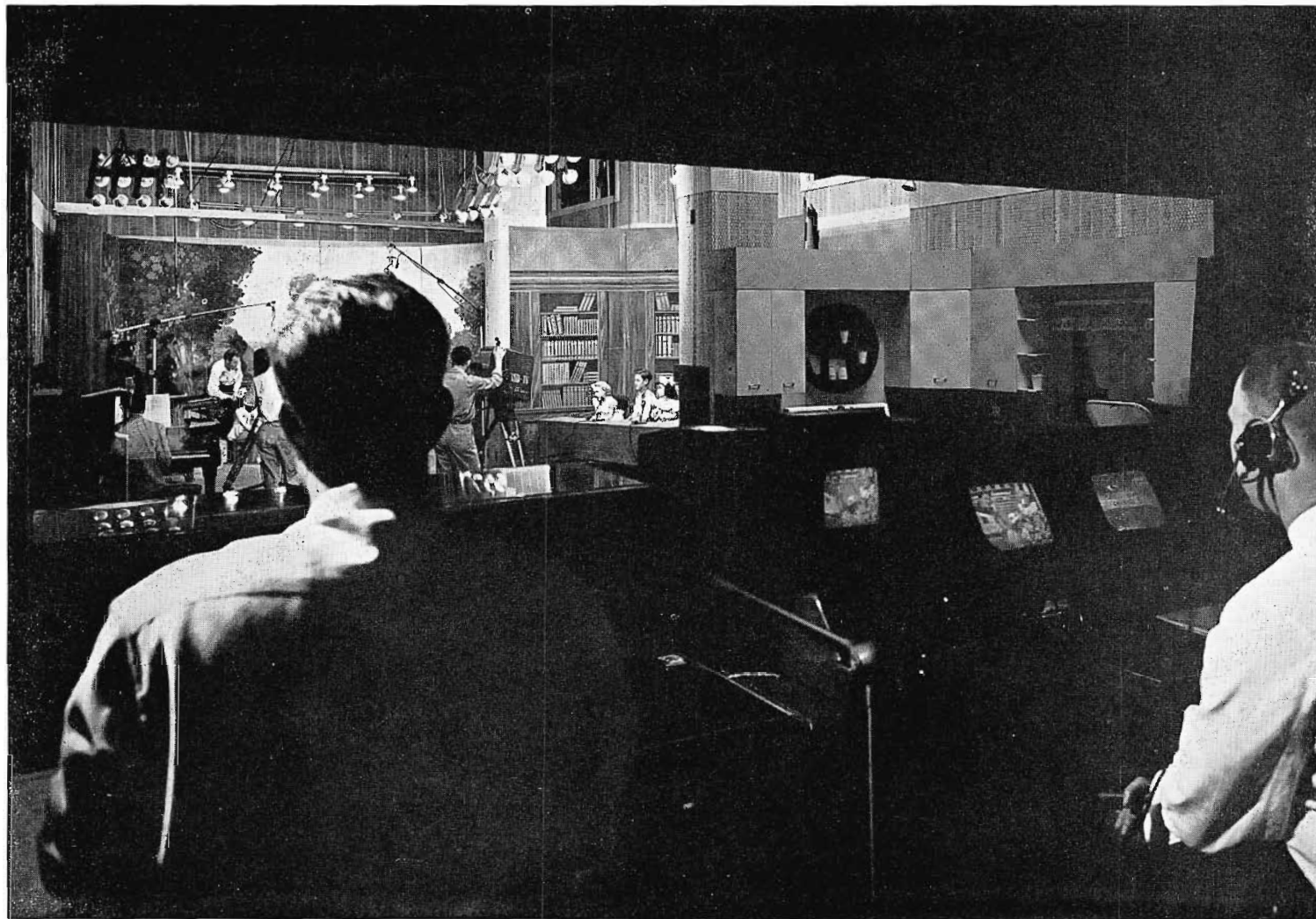

FIG. 1 (above). KSD's new television studio as seen from the control room. The studio extends about 50 feet beyond the control room and can accommodate a series of sets in the bays along one side and across the end.

KSD TELEVISION FACILITIES

KSD-TV's studios are located on the first floor of the Post-Dispatch Building, in the same general location as the AM studios. This arrangement is convenient and lends itself to economy of operation. The main television studio is 24 feet by 50 feet with a 20-foot ceiling. An alcove at the center of one long wall is useful in that it provides an additional staging area. The studio is acoustically treated with rock wool blanket which is protected with 1-inch wire mesh. A 4-foot base of perforated transite has been provided as well as a 1-foot strip of the same material at the 10-foot level on the wall so that flats and props will not damage the acoustical treatment.

The studio was made as acoustically dead as practical and in addition isolating walls were installed for the two sides which

By J. E. RISK
Chief Engineer

are to the outside of the main building. This acoustical treatment has proven to be very satisfactory. The floor is of concrete resting on 2 inches of cork. No paint of any kind has been used on the floor to avoid the softening effects of the necessary acid treatment. Rather the floor has been treated with a non-skid wax. A lighting grid was provided with a 3½-foot mesh over the entire ceiling area. This has been extremely useful in facilitating the proper location of lights, microphones, drapes, etc. The studio area, while fairly compact is complete in providing the necessary facilities such as dressing rooms, an actor's lounge, adequate control room and a fair amount of prop storage space close at hand for storing items in which

there is the most traffic. The main storage room is located in the basement, handling the large items and dead storage. A large Client's Observation and conference room

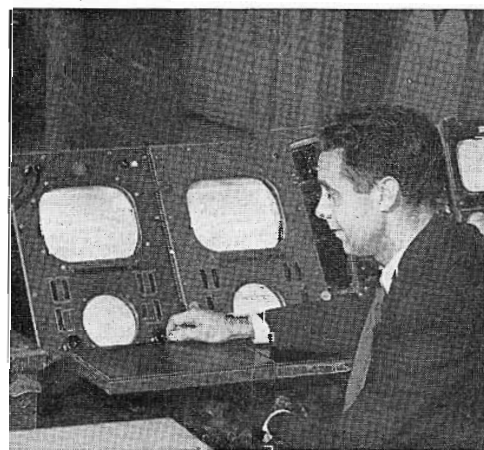

Closeup of Video Monitors with Mr. Ray Johler, KSD-TV Operations Supervisor, at the console.

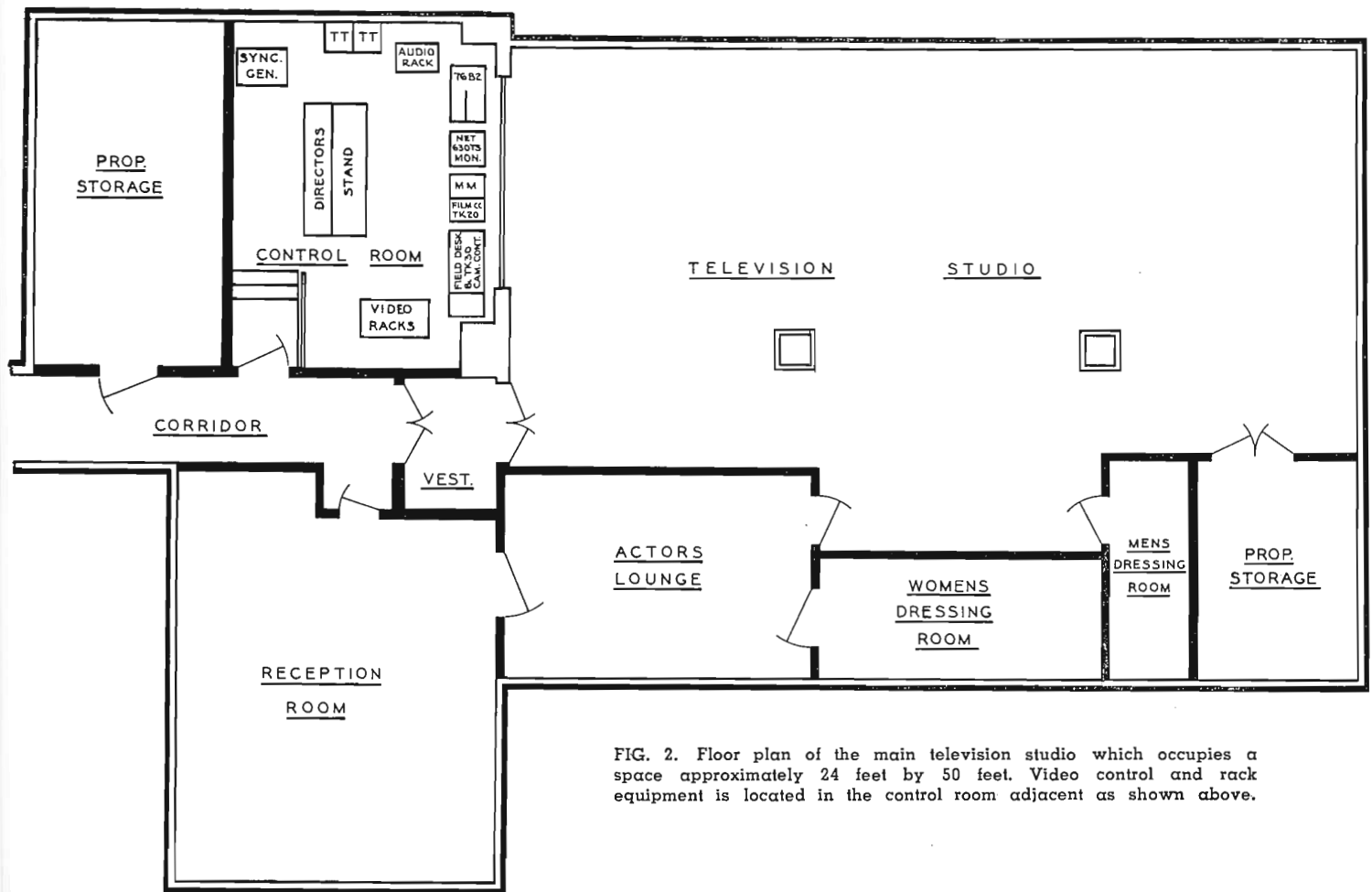

FIG. 2. Floor plan of the main television studio which occupies a space approximately 24 feet by 50 feet. Video control and rack equipment is located in the control room adjacent as shown above.

(Below) Mr. J. E. Risk, Chief Engineer of KSD-TV.

FIG. 3 (below). A second TV studio (converted from AM setup) is used as a completely operating "kitchen". Mr. Lawrence Trombly, KSD-TV Maintenance Supervisor, is shown at Control Console.



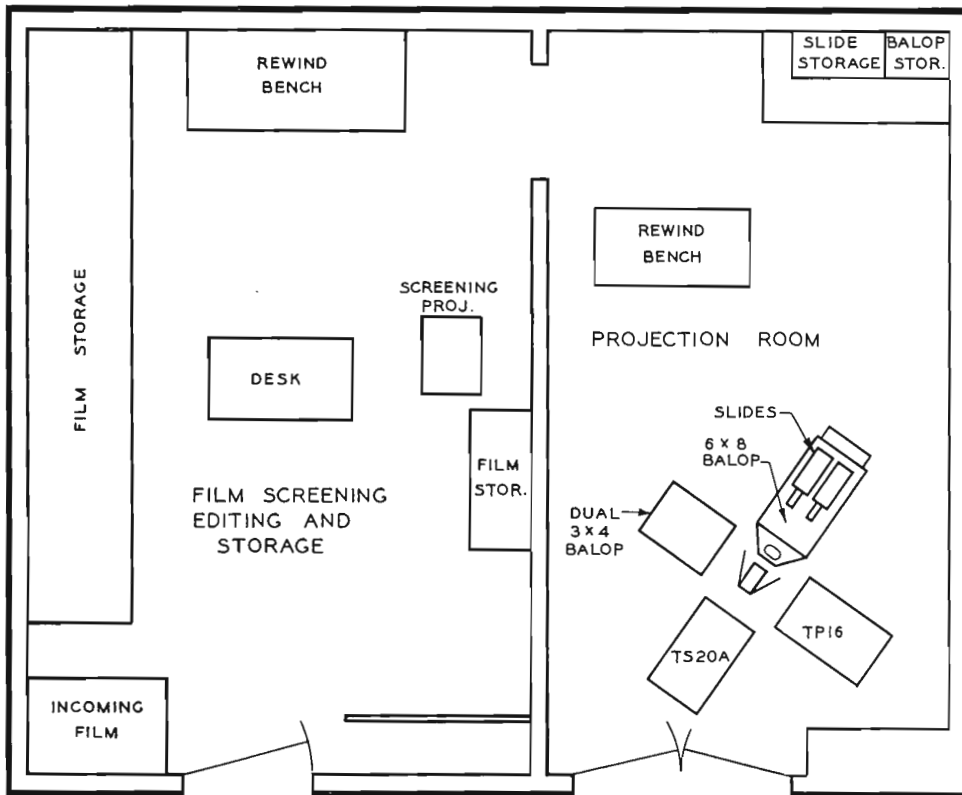
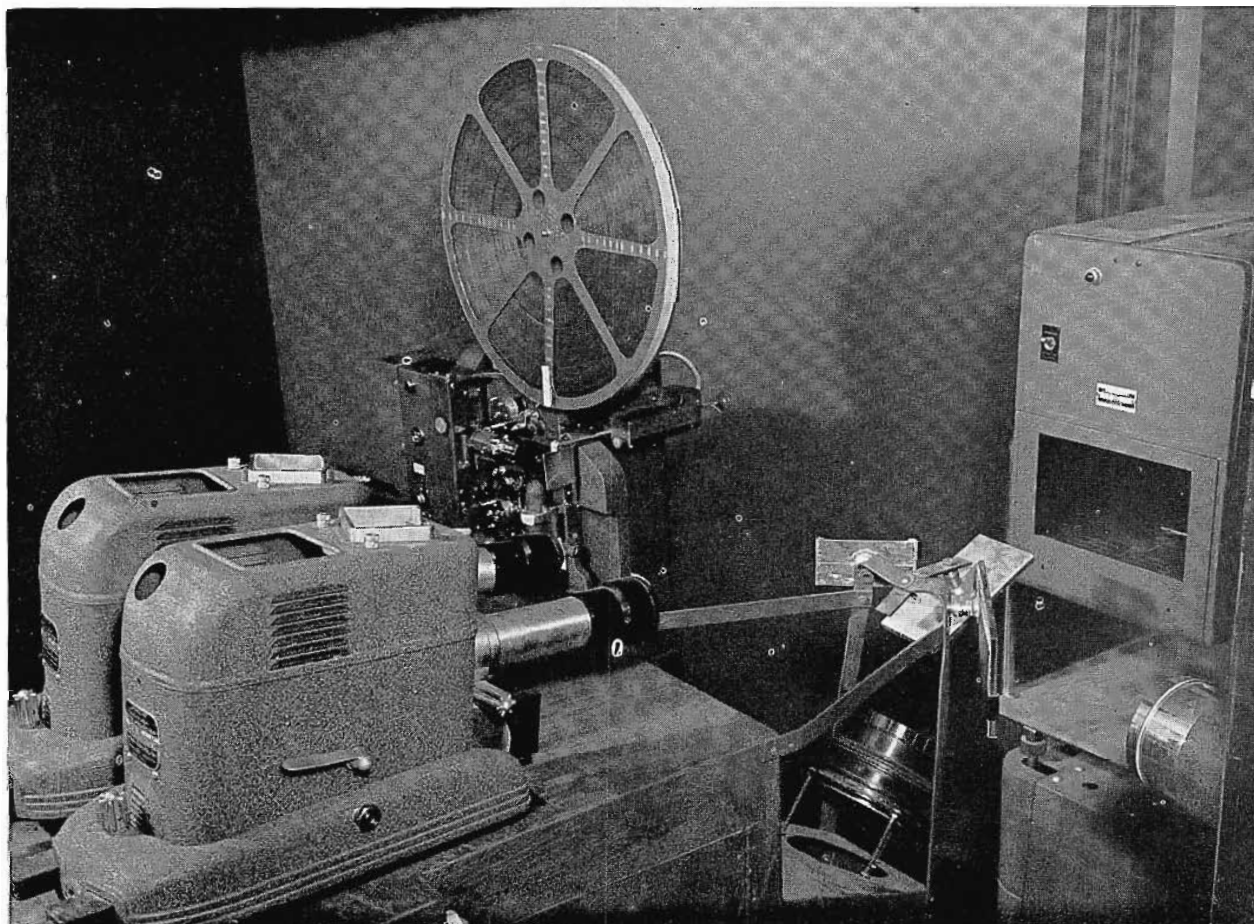

FIG. 4 (above). Floor plan layout of the KSD-TV Film Projection, Film Screening, Editing and storage facilities. Floor space occupied is approximately 600 square feet.

FIG. 5 (below). Corner-view of the KSD-TV Film Projection room showing the film projector and multiplexing system.



is located above the control room with observation space for the general public being located along the side of the studio above the dressing rooms.

The studio is equipped with two TK-30 cameras, a TK-20 film camera, a TG-1A sync generator, a 76-B-2 consolette, and two 70-C-1 turntables. The switcher is a composite unit designed and built by KSD-TV utilizing a TA-5B stabilizing amplifier and four sections of a distribution amplifier for adding the synchronizing pulse and laps. All cameras including the monoscope as well as network and remote appear on the switcher. A normal circuit to the transmitter is provided to allow any of these units to bypass the switcher freeing it for rehearsals. The switcher is relay controlled, and the control position is movable, and is used at the director's stand for live programming and at the camera control position when only network and film are being handled. The house monitors can be connected to either an air or preview bus by individual switches.

The projection room is located on a mezzanine floor where space was available for film storage and cutting. The film operation has grown so fast that the 600 square feet of floor space provided is scarcely enough. The projection equipment



FIG. 6 (above). Transmitter Room view showing flush mounted RCA transmitter, Supervisory Control Console and equipment racks. Mr. Gordon Rustemeyer, Transmitter Supervisor, is shown at the controls.

consists of one RCA TP-16A projector, a TK-20 film camera, two composite opaque projectors, one a dual unit, and two LaBelle model 301, 2x2 inch automatic slide projectors equipped with 7½-inch lenses providing optical dissolves and quick changes of slides. As many as 12 slides or more can easily be handled in 20 seconds. The composite multiplexing system allows for six pieces of projection equipment to be fed into one film camera. Optical dissolves are used between all six units, except the projector, which is equipped with the usual douser mechanism. The controls for all of the projection equipment are located at a position behind the slide projectors to provide efficient operation.

A second TV studio (see Fig. 3) just converted from an AM studio is equipped with a complete operating kitchen to handle the daily homemaking program. In addition, this studio will handle programs such as interviews, news and small instrumental

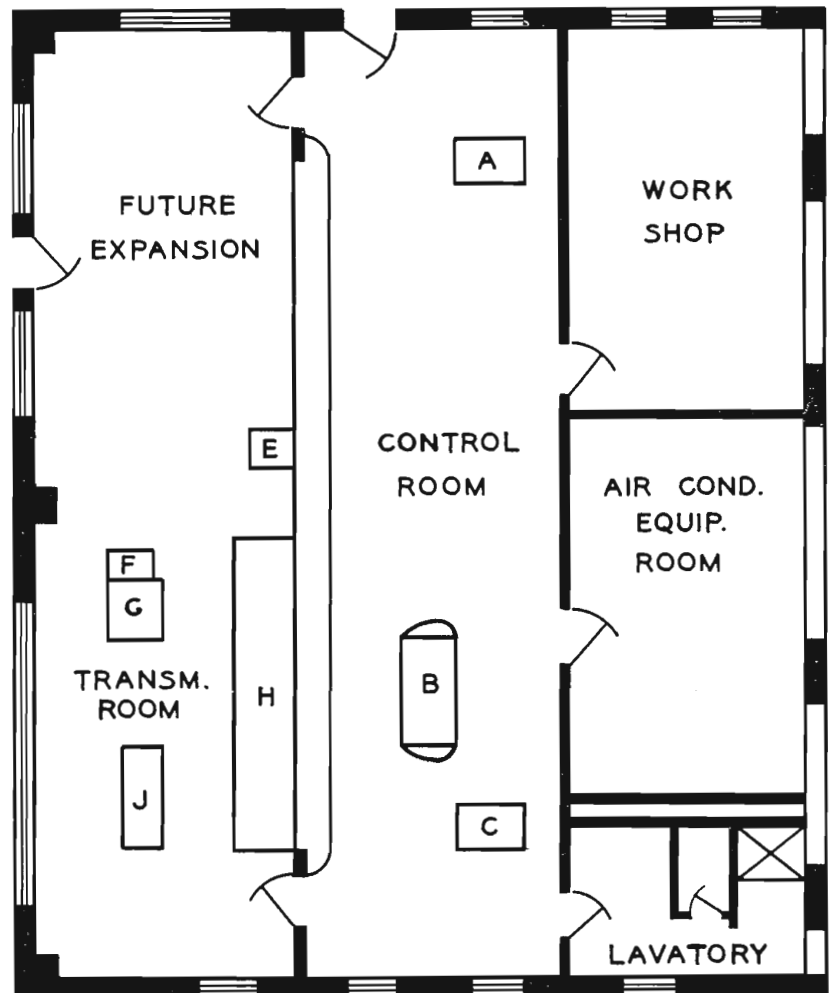

FIG. 7 (at right). Floor plan of the Transmitter Room which is located in a penthouse atop the St. Louis Post-Dispatch Annex Building. Key to floor plan as follows: A—Equipment Rack, B—TV Console, C—Equipment Rack, E—Tube Rack, F—Diplexer and Dummy Load, G—Sideband Filter, H—TV Transmitter, J—Water Circulation Pump.

groups. An observation room has been equipped to play the dual role of observation room and announcers' booth for this studio. The studio is equipped with two RCA TK-30 cameras, an RCA TS-10A switching unit, a 76-C console, the synchronizing pulses being supplied from the other studio. Five RCA 2T51 receivers are used as monitors. Three of these receivers are used in the control room to monitor incoming network or remote, film camera and air programs. One is used for a studio monitor, another in the observation room. The film camera control is located in the con-

rol room for the large studio which serves as master control. Network remote and film camera circuits are fed to the switching unit in each studio. The change from one studio to the other is accomplished by operating a single switch which controls both audio and video.

The communications system is essentially the same for each studio. It provides for the director, technical director and the camera control operator to talk to the camera men, projectionist, stage crew and floor manager. A party line system without talk-back from the studio has proven

to be most satisfactory. In addition, an intercommunication system has been set up between each studio, the projection room, transmitter and shop.

The mobile unit has been used for nearly three hundred remotes, while the greatest portion of these were baseball, all types of sporting events have been covered. In addition, KSD-TV has picked up a speech by President Truman, Vice-President Barkley's wedding and the funeral of an important civic official.

Cables have been permanently installed wherever several events are to be covered in one season. This has saved a tremendous number of man hours in the time required for setting up remotes.

The TT-5A transmitter is located in a penthouse on the roof of the Post-Dispatch Annex building. Adequate shop and storage space are provided as well as room for expansion. The transmitter room is air conditioned. This has provided clean air and an even temperature which is helpful to any operation striving for uninterrupted service. The dummy load, sideband filter, water pump and cooling unit are located behind the transmitter as shown in the floor plan. All units are connected with floor ducts.

The TF-3A Super Turnstile antenna is supported by a 450-foot Ideco tower which is atop the Annex building. The modification of the building to support such a structure was a considerable feat. It was necessary to enlarge the concrete beams of the building under the tower by increasing the radius approximately 6 inches to depth of two stories in order to properly distribute the load. The whole antenna structure is 544 feet above ground level and 530 feet above average terrain.

KSD-TV's operating staff consists of 24 men. The above figure includes four projectionists, and three stagehands. The technical operations supervisor is Mr. Ray Johler and the maintenance supervisor is Mr. Lawrence Trombly. The weekly program schedule has increased rapidly in the past few months and has now reached 95 hours per week. Of this, 35 percent is local studio production, 35 percent live network programs and 30 percent film programs including kinescope film.

All of the equipment has performed extremely well even under the strain of nearly four years of continuous service and has shown no sign of deterioration. Failures other than tubes are rare and 600 lines resolution from all cameras is routine. Much of KSD-TV's success can be attributed to the excellent equipment.

FIG. 8. View of the KSD-TV 3-bay RCA Super Turnstile Antenna and tower located atop the Post-Dispatch Building.

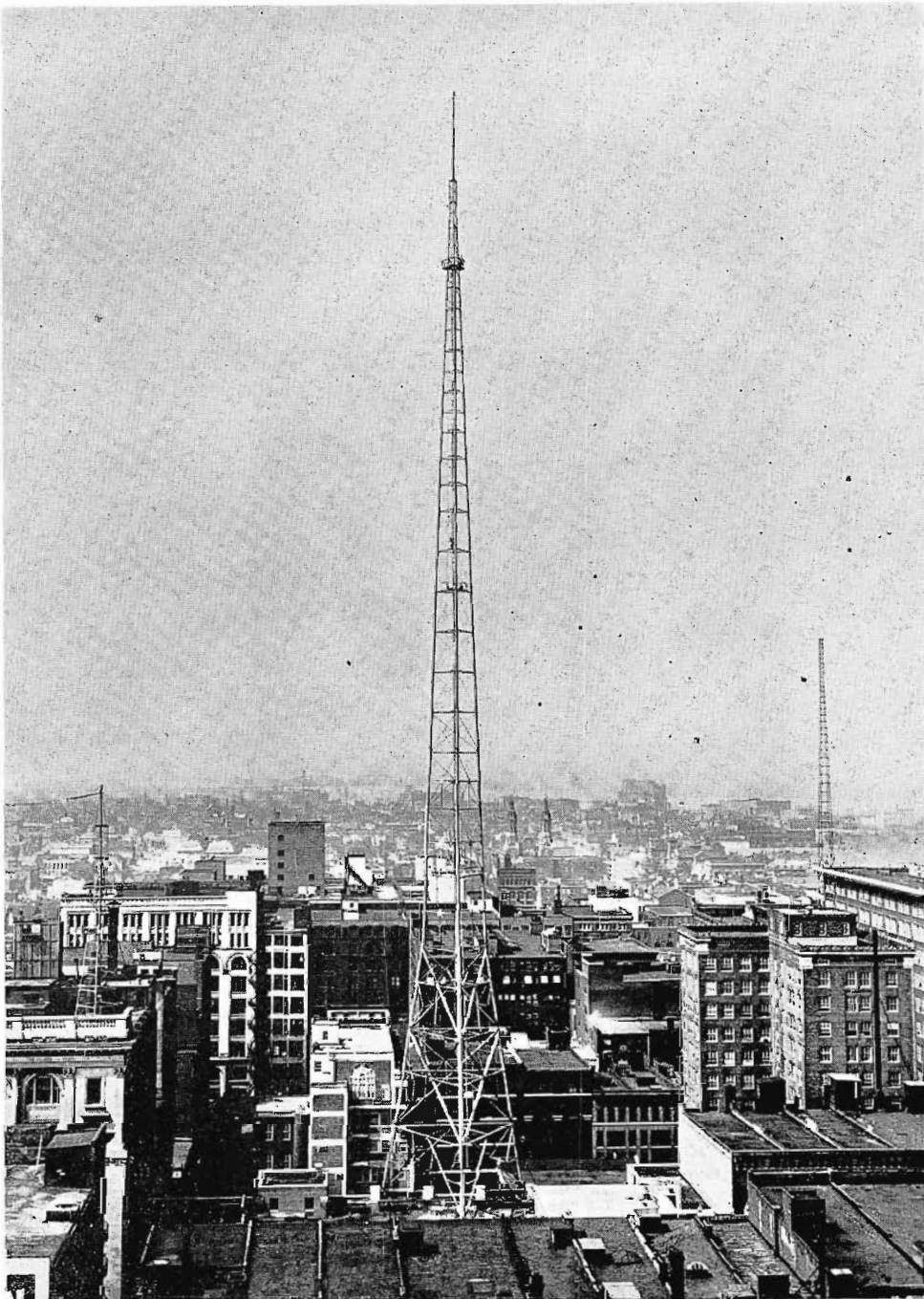

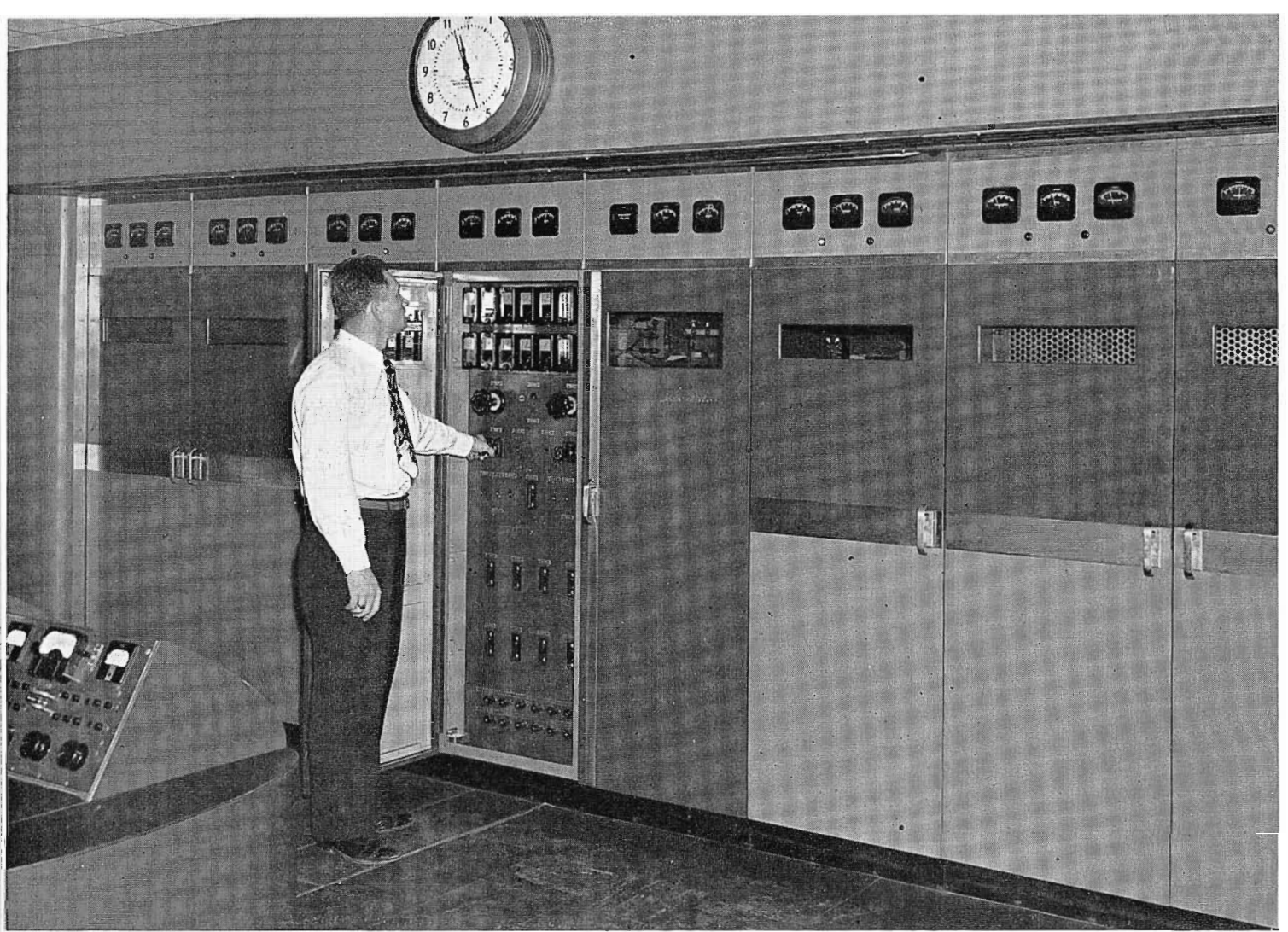
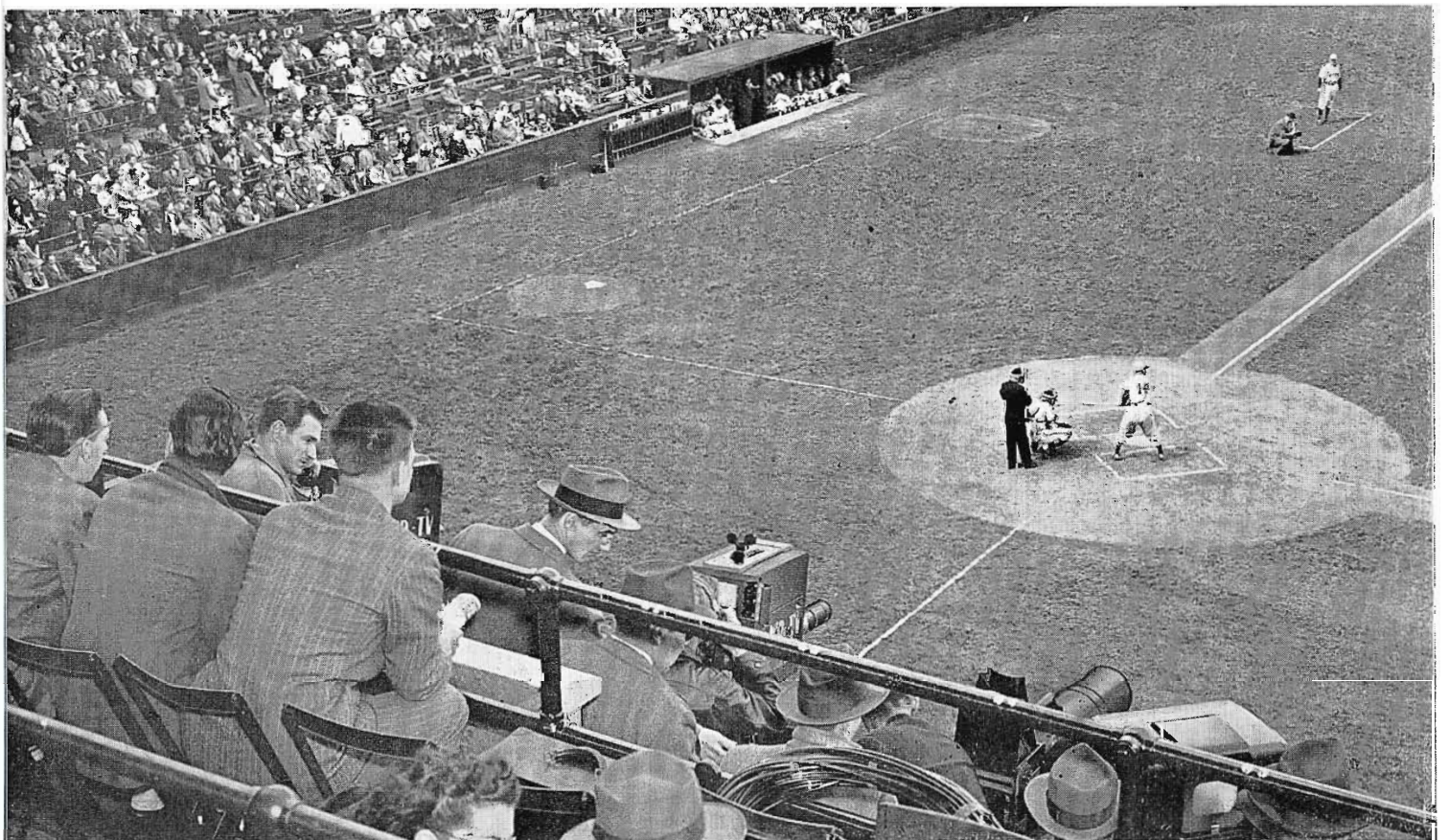

FIG. 9 (above). Front view of the TT-5A, RCA 5-kw transmitter which is flush-mounted in one side of the transmitter room. At left, part of the transmitter control console is visible.

FIG. 10 (below). View of a TV Pickup at Sportsman's Park, St. Louis, showing the camera positions. Mr. Harold Grams, Program Director, is shown between the two cameras.



THE REQUIREMENTS OF TELEVISION STATION DESIGN

By DR. WALTER J. DUSCHINSKY*

PART II The Planner's Approach To TV Station Design

In Part I, the general approach to the planning of a television station was discussed. The part played by a planning organization was briefly mentioned. In this second part we will discuss more specifically the work of the planner from the

view point of the station owner, the engineer and the producer.

THE BUILDING ELEMENTS

The planner may be compared with a builder or constructor since the materials he uses are as real as bricks, cinder blocks and mortar. The basic materials of the planner are the technical, production, administrative and public areas. Each of these areas must be set down and properly

tabulated in order to give them their unimpaired functional use—in the same way as the builder will make quantitative estimates of his materials before he starts to build.

THE BUILDING PATTERN

Both the builder and the planner will use a different pattern for each task in

* 425 E. Fifty-third Street, New York 22, N. Y.

THE PLANNER'S TOOLS

DATA

ALL FACTS ON POLICY OF STATION AND NETWORK.
PHYSICAL CHARACTER OF STATION.
TIME ON THE AIR AND ITS BREAKDOWN.
PROGRAMMING PRODUCTION EQUIPMENT, ETC.



AXIOMS

LAWS OF T.V.
PLANNING OF EMPIRICAL NATURE DEVELOPED BY THE PLANNER

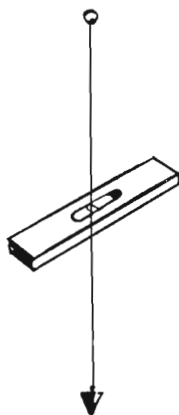

RESEARCH

RESEARCH WILL INQUIRE INTO THE DATA, STATISTICS, POLICIES AND EXISTING PHYSICAL LAYOUTS OF T.V. STATIONS AND ESTABLISHED BASIC RESEARCH FILES.

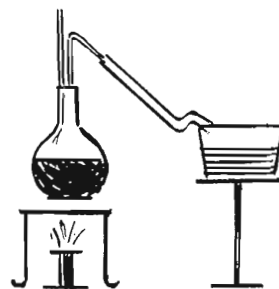

ANNALYSIS

TO PRODUCE AN ANALYSIS FOR ONE PARTICULAR CASE ALL AVAILABLE DATA, RESEARCH FILES AND AXIOMS ARE USED.



EDITOR'S NOTE: This is the second part of a four-part article written especially for BROADCAST NEWS by Dr. Duschinsky, well-known consultant on television plant design. The first part, which appeared in the last issue (Vol. No. 61) of BROADCAST NEWS, dealt with the general problem of TV station design and, in particular, with the relation of the various basic elements to the over-all scheme of layout. In this second part Dr. Duschinsky indicates the general technique which the TV station planner follows in attacking the design problem. In the third part of the article, appearing in the next issue, he will portray the evolution of a general design. In the fourth part, which will appear in the succeeding issue, he will show the application of this general design to a specific station problem.

It will be noted that the methods which Dr. Duschinsky employs in TV station planning are fundamental, and apply in the same general way to all industrial planning. The special consideration which he gives to traffic flow between areas is extremely important in all broadcast station planning—whether AM, FM or TV. Thus, it is felt that everyone connected with present or future planning of broadcast stations—and that includes almost all BROADCAST NEWS readers—will benefit from a study of these articles.

Caution: The color key used in the illustrations accompanying this second part is slightly different from that used in the first part. If this is noted there should be no difficulty in interpreting these illustrations.

order to create his building surfaces. For the planner, this pattern is his functional chain. Each building material lends itself to a variety of patterns and these patterns must be carefully arranged to provide the expected functional over-all unity without impairing the working proper to each individual member. The different patterns—

technical, production, and so on, have to be considered on their own merit, but also in relation to the whole building that the planner is creating. A simple building will demand a simple pattern and a large and complex station a complicated and highly organized one.

THE STRUCTURE

The builder and constructor are aware of the need for flexibility and expansion in all structures ranging from the contemporary private residence to the large industrial plant. Television stations are no exception to this rule. To provide such flexibility and expansion, the structure has

THE PLANNER'S WAY OF BUILDING

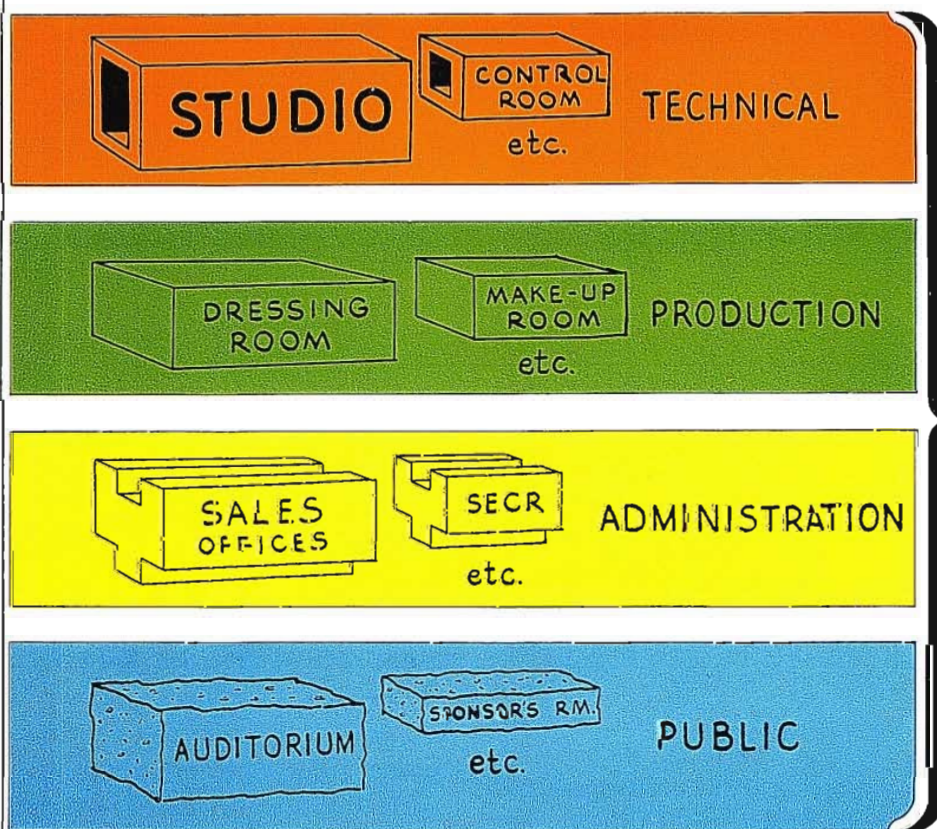

**THE BASIC ELEMENTS
•
THE PLANNER'S BUILDING MATERIALS**

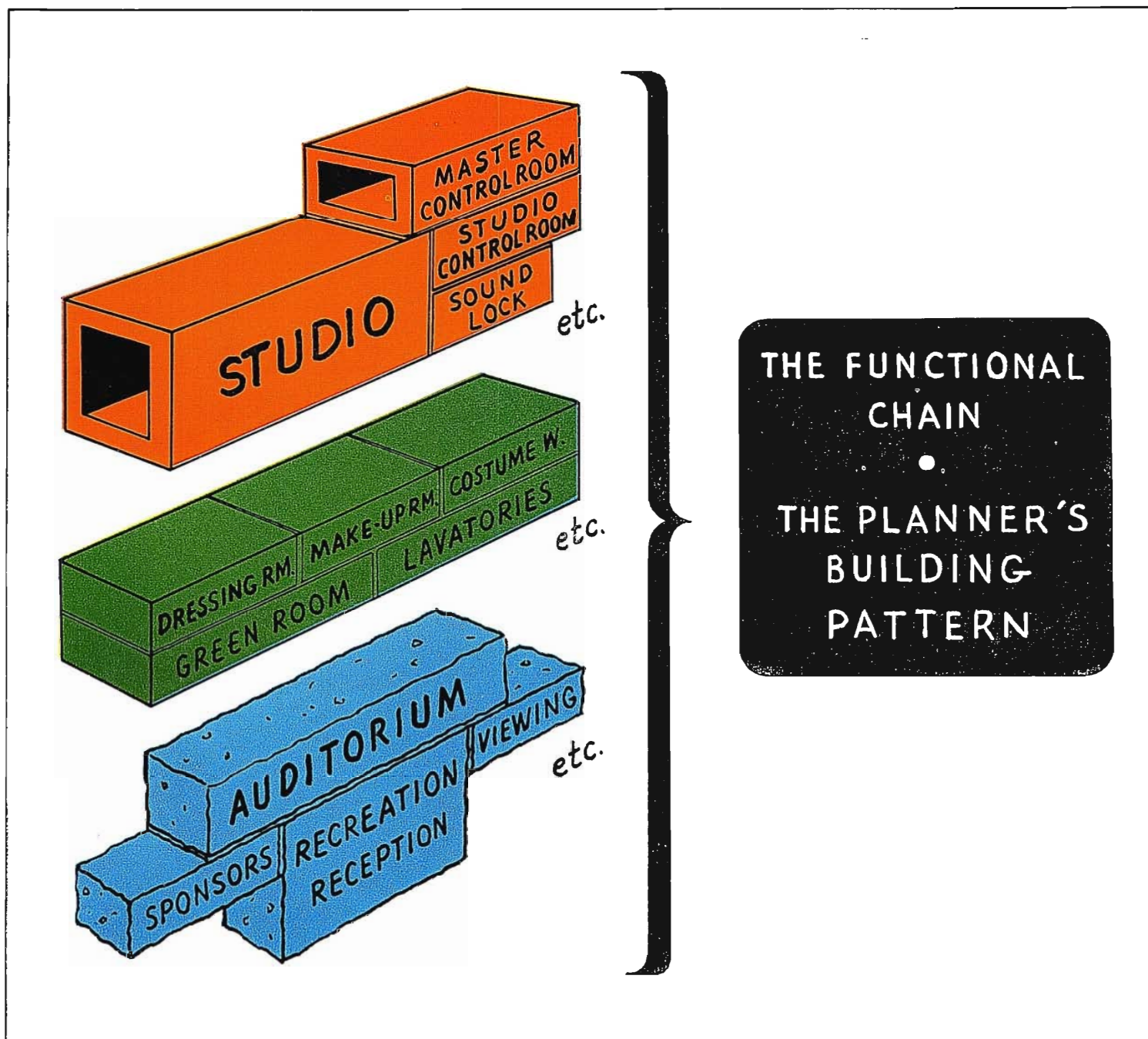

to consist of a well formulated free skeleton. Such structures—which should comprise the only fixed element in the physical planning—are the vertical traffic shafts, such as staircases, elevators, ramps and the vertical main duct system of electrical and mechanical nature. There are no other limitations in this primary planning for structure. All horizontal traffic and horizontal ducts and trenches rely on proper vertical distribution as, in the case of the builder, the column spacing decides the girder and floor construction.

THE BUILDING PRACTICE

To proceed with the building the planner, like the builder, needs tools. His are fourfold—data, axioms, research and analysis, and these compare with the excavation tools, building instruments and working drawings of the builder.

By the scientific use of these tools, the planner will be able to use his materials properly, shaping them into proper functional chains, producing the right building skeleton and thus finish the whole construction of the television station in a workmanlike and efficient manner.

THE PLANNER'S PRODUCT

Like any other craftsman, the planner will be judged by the quality of his finished product. For the builder, this is a physical product, while the planner's creation shall be a well rounded complete study and analysis, fully illustrated and self explanatory. The station owner with architect and engineering department should receive complete information regarding master plan policy, development recommendations, specific information, data and requirements permitting them to prepare

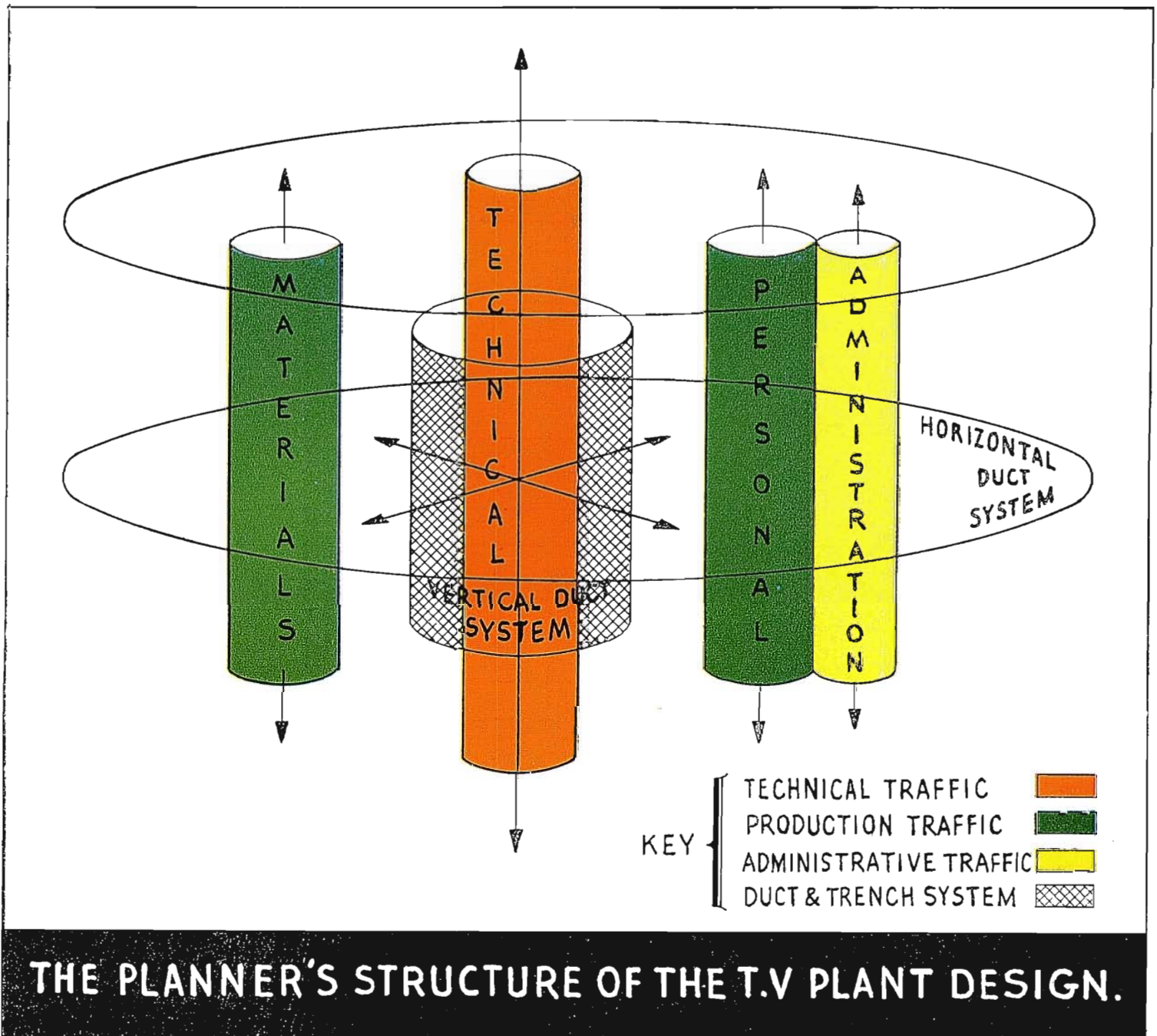

without difficulty detail design and working drawings of the station.

The value of this product can be measured in the money saved in capital investment, such as providing and establishing essential areas and reducing certain spaces and locating them in the less high dollar value levels. More money will be saved by the preparation of well organized traffic flows which are important for the long term operation and maintenance of the station.

General maintenance and production expenses will be reduced to essentials—by

not guessing at the value of the essentials, but by a scientific method of elimination. The savings of the first month's operation of a medium sized television station will prove the value of such planning and will easily pay the study fee.

The planner should help the station owner to see problems in advance—before any definite drawings have been prepared by the architect. This is important because, as mentioned before, information collected by the architect today is, at best, individual expressions of the operational department

of the client. Only a planning organization can prepare and evaluate data and information of many sources. The best architectural and engineering design will fail if the information is based on assumptions, guesses and personal opinions. Therefore, it is the job of the planner to give the architect correct information and expound to him the needs of the station.

A COMPLEX PROJECT

The collection of data, statistics, graphs, program time, breakdown tables, etc., for

GENERAL COORDINATION OF BASIC REQUIREMENTS.

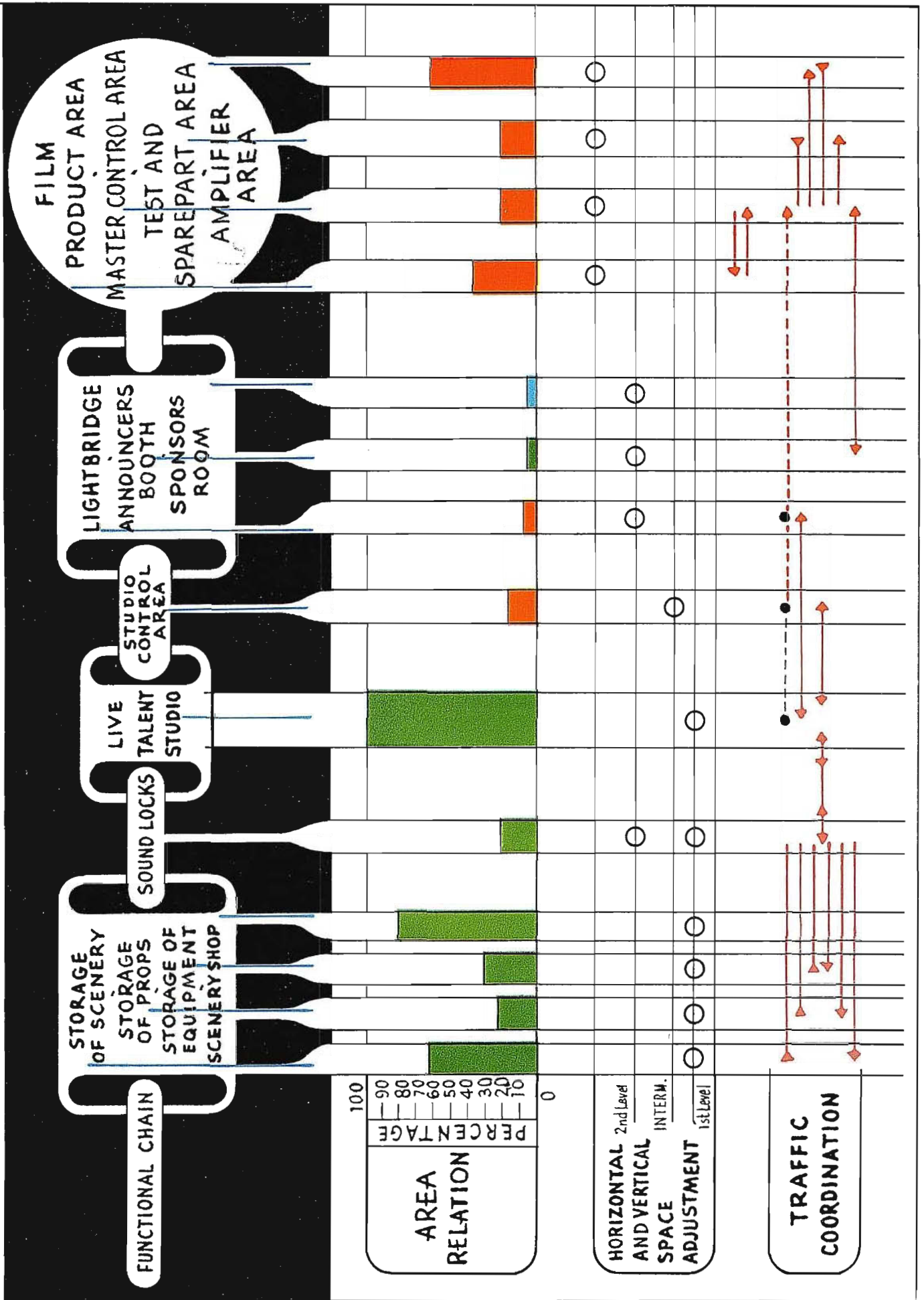

THE PLANNER'S PRODUCTS

FOR THE T.V. STATION MANAGEMENT

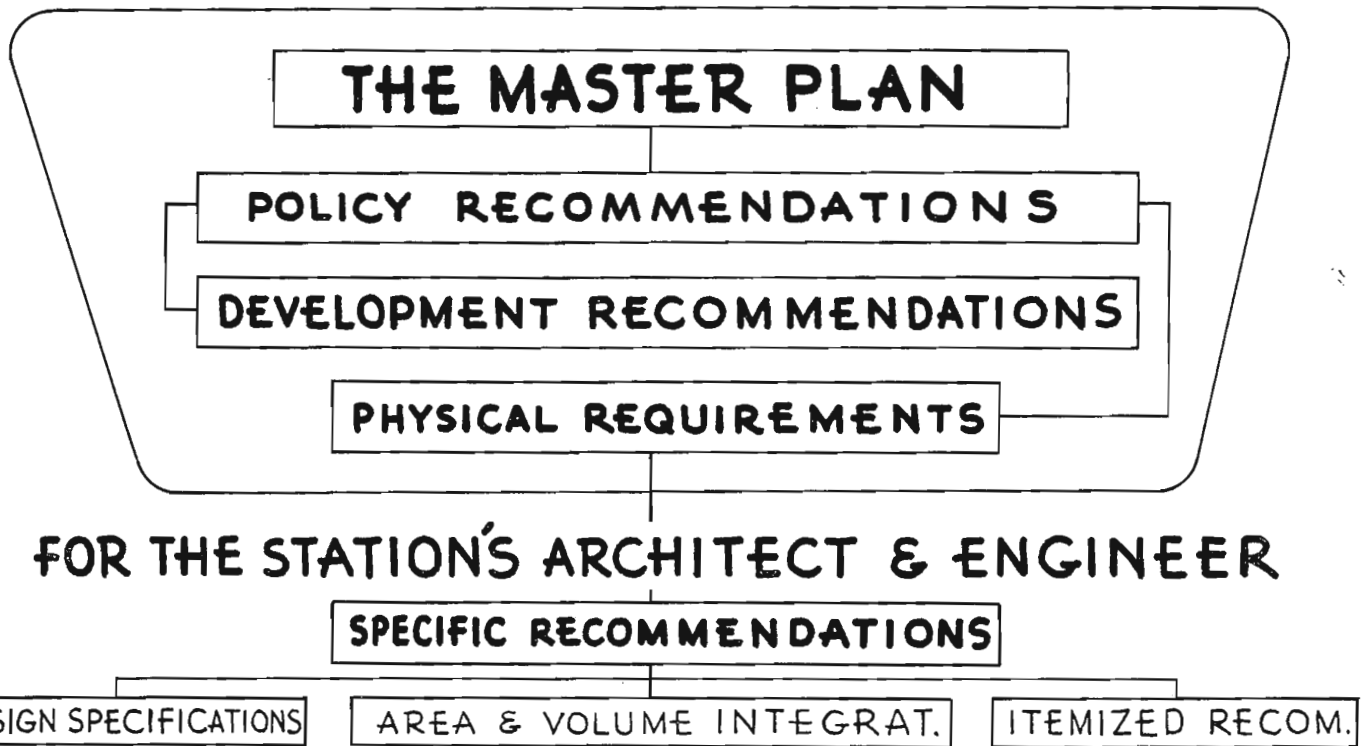

each specific job is a major task. The determining factor in producing any space and volume must rightly develop out of information collected and analyses by the planners' staff. Existing stations must be scanned to provide background information, drawings must be studied and programming tables be broken down so as to determine where immediate improvements have to be made. Comparison of expansion ratios of stations for each functional chain have to be prepared. Besides this, there are aspects of television station design that as yet have barely been touched. One of these, a major one, we have designated as "the Tempo of adaptation" which determines whether the station is to be de-

signed ahead of, in pace with, or behind general industry trends.

The increase in the general space requirements of stations is indication of undoubted growth. A more detailed cross sectional cut through special areas will reveal the complexity of television plant expansion and the difference in increase for each area. This requires careful scrutiny before any physical design recommendations are developed.

The accompanying illustrations indicate the interrelation of spaces in a developed functional chain, the relation towards the whole, their horizontal and vertical adjustment and their traffic pattern. Some of the

foregoing will give a general idea of the complexity of a planning job for a television station. Research and analysis will sometimes take months, but the result will justify the expense of time and money. Planning should not be rushed. The gradual spread of TV is an advantage in this respect—in that it permits future owners and operators to use the intervening time for an exhaustive analysis of future plans. Stations looking forward to a future expansion of their present plant facilities should also take ample time now to consider and plan ahead.

(Part III of this article will appear in the next issue)

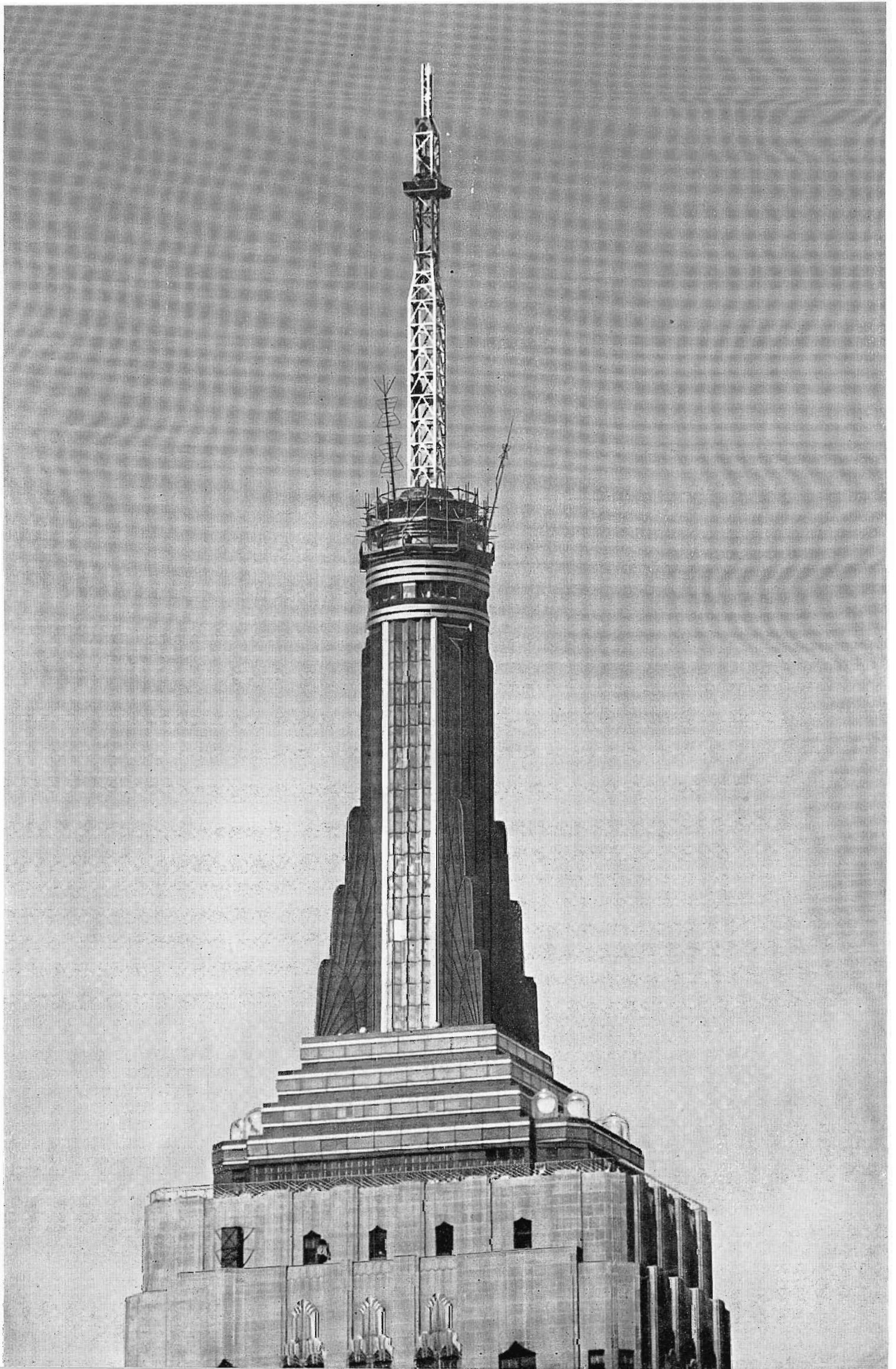

The 222-foot tower which will support five TV and three FM antennas 1472 feet above New York City is nearing completion. This photograph, taken with a telephoto lens, shows part of the third and last tower section to be erected. Completion of the tower will be followed by assembly of the Super Gain dipoles and screens around the four sides of the tower. A 4-section Super Turnstile will top the tower.

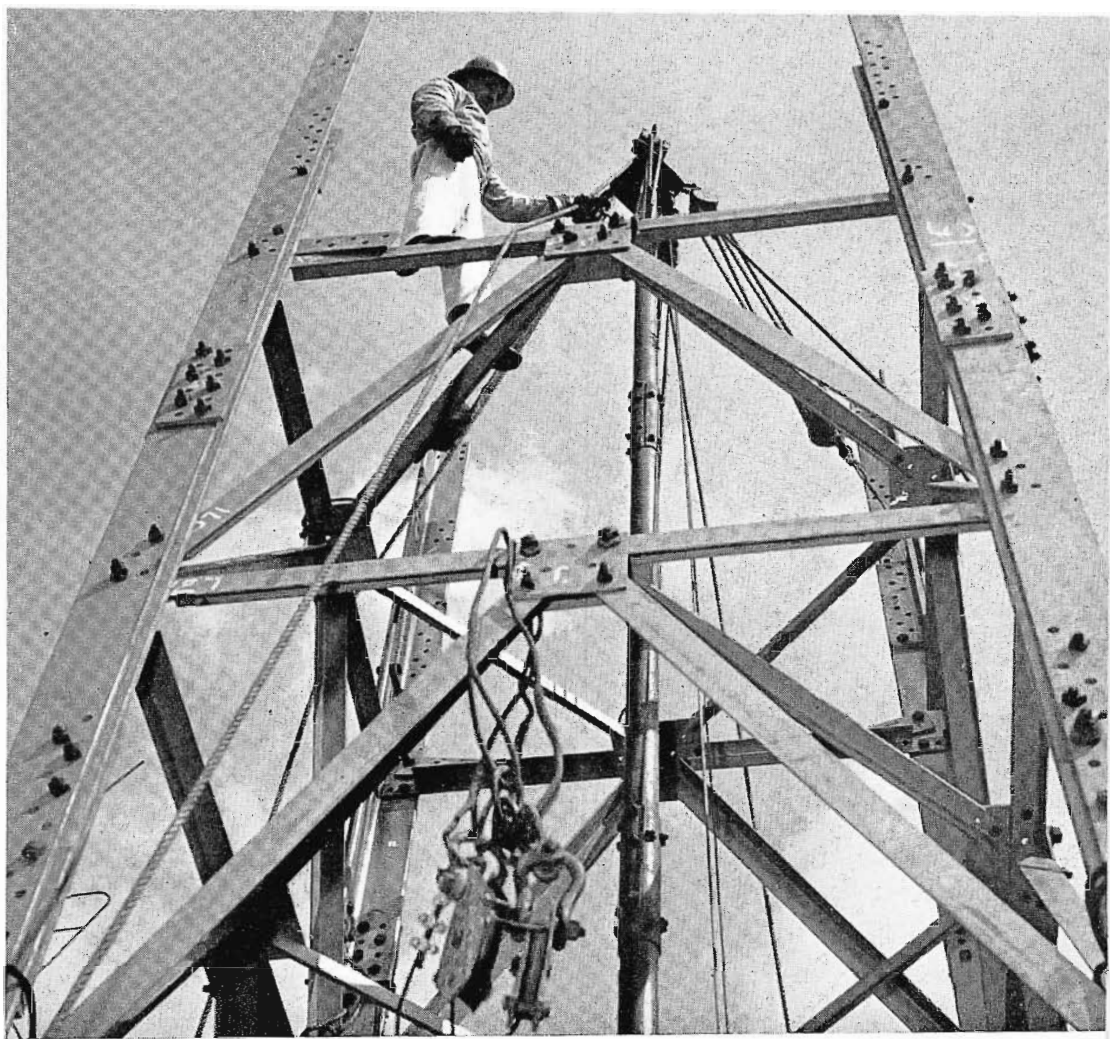

In raising the tower, steel sections are brought up inside the Empire State elevator shaft and then raised to position by block tackle on suspended gin pole shown at the top of tower.

EMPIRE STATE TOWER NEARS COMPLETION

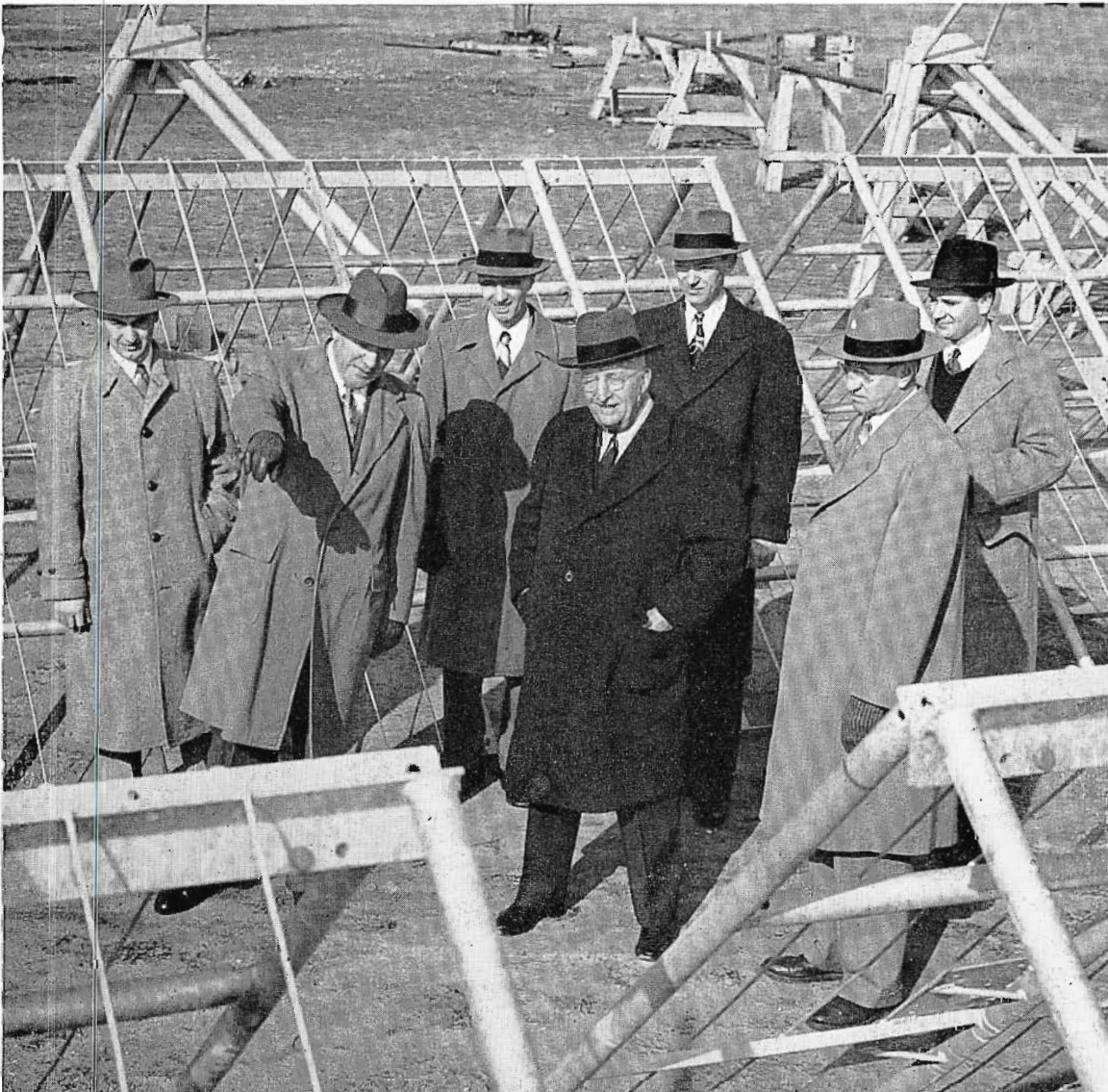

W. W. Watts, Executive Vice President of RCA Engineering Products, points out interesting details of the CBS antenna to General Hugh A. Drum, President of Empire State, Inc., who inspected the antenna prior to shipment from Camden. Others in the photograph are, left to right: Dana Pratt, RCA Sales; Mr. Watts; H. E. Gihring, RCA Engineering; T. A. Smith, RCA Engineering Products Sales Manager; L. J. Wolf, RCA Engineering; and C. W. Lyon, Jr., Executive Vice President of Empire State, Inc.

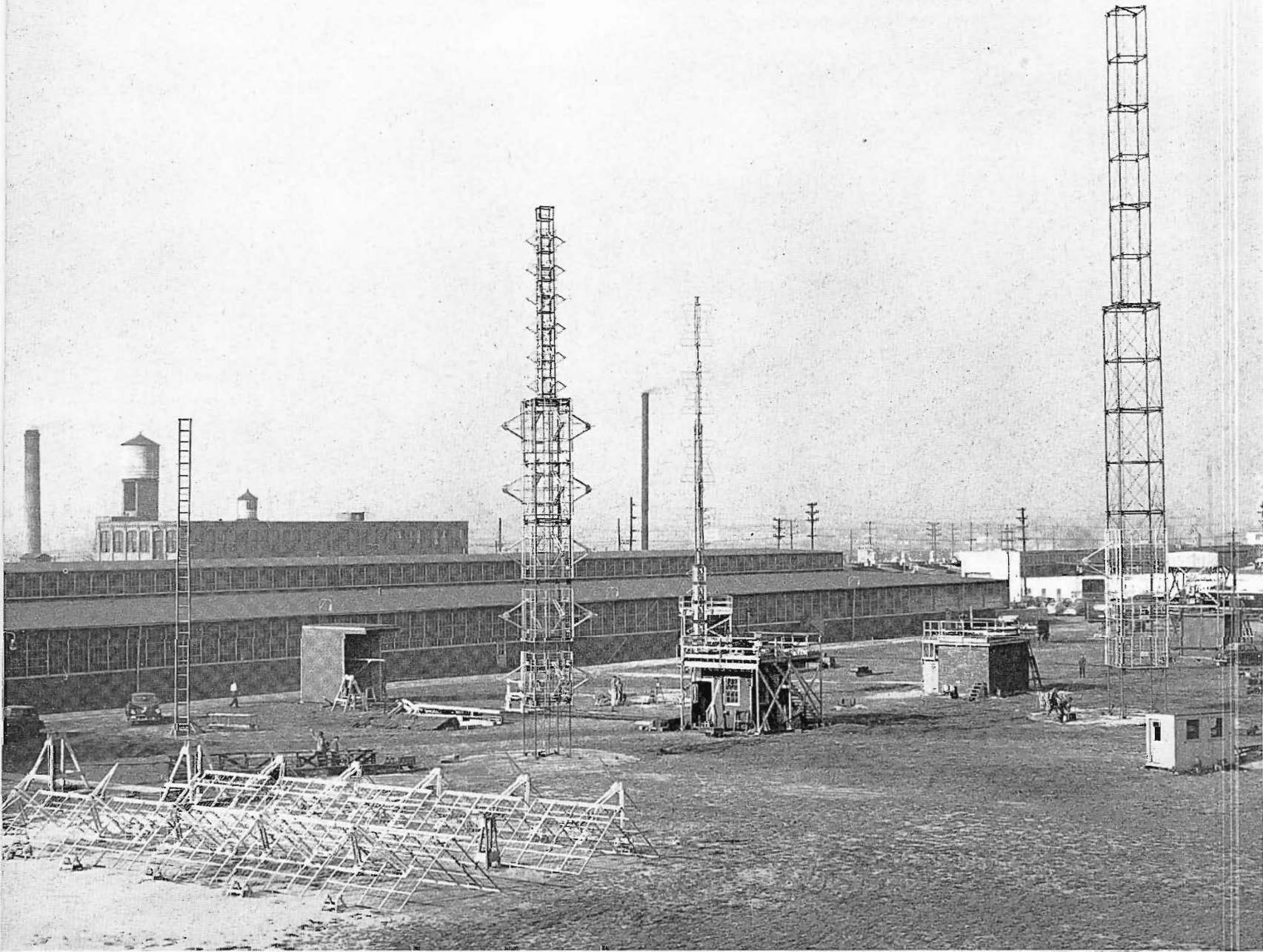

View of the RCA antenna test grounds at Camden showing towers which were erected especially for the Empire State antenna tests. Radiating elements are assembled on the towers and adjusted for minimum interaction and feed line SWR. Elements in the foreground are those of WCBS-TV.

RCA EMPIRE STATE ANTENNAS GIVEN FINAL TESTS PRIOR TO SHIPMENT

Operation tests are being conducted daily on the five TV antennas which will eventually be erected on Empire State Building early next year. The antennas, which will be used by WJZ-TV, WJZ-FM, WCBS-TV, WCBS-FM, WPIX, WABD, WNBT, and WNBC-FM, are being tested separately and together to determine the effective decoupling which can be obtained from these antennas.

Accompanying photos show the four towers which have been constructed at the

RCA test yard in Camden. These towers are arranged to support adjacent antennas in the same manner in which they will be located on the tower above the building. The largest tower in the photo supports the elements of Channels 2 and 5. To determine the possible decoupling, energy is fed into one antenna and the amount picked up by the adjacent antenna is measured. For instance, the Channel 2 antenna is excited and the energy measured which is picked up by Channel 5. Then the process is reversed, the Channel 5 an-

tenna is fed and the pickup by the Channel 2 antenna is measured. Tests of this nature are made to assure that the energy picked up by an adjacent antenna does not exceed limits which can safely be fed back to the output circuits of the transmitter.

After the decoupling tests are completed the standing wave ratio is measured for each antenna while in the presence of other antennas, and adjustments made for lowest SWR.

A. Channel 2 dipole being hoisted into position for assembly to the backing screen on the tower. Note WCBS-FM dipole installed between the TV elements. The FM signals of WJZ-FM and WNBC-FM will also be radiated from the Empire State tower.

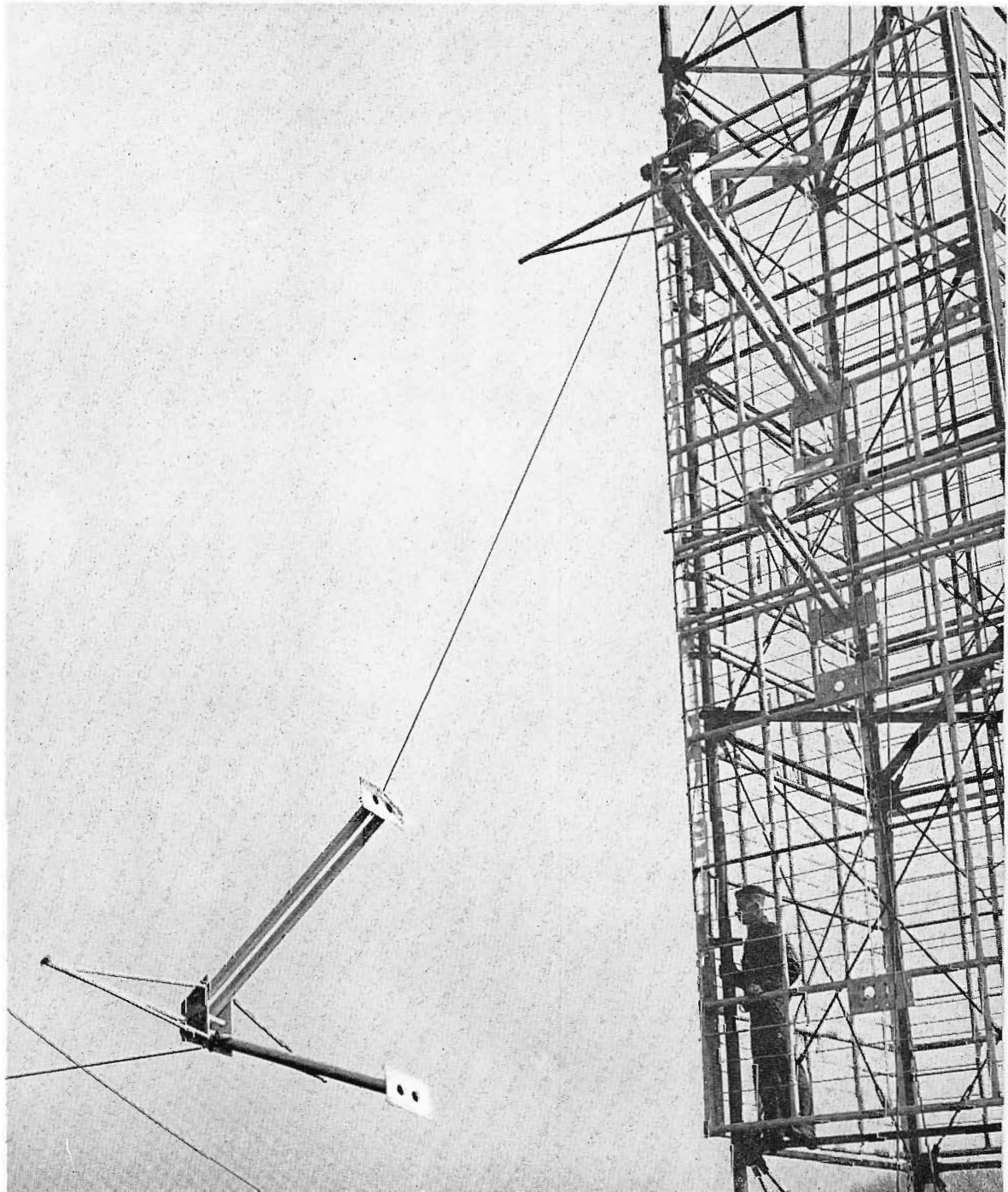

Channel 2 radiating elements being assembled on the screens prior to erection on the tower. Prefabrication of the screens and dipoles speeds erection.

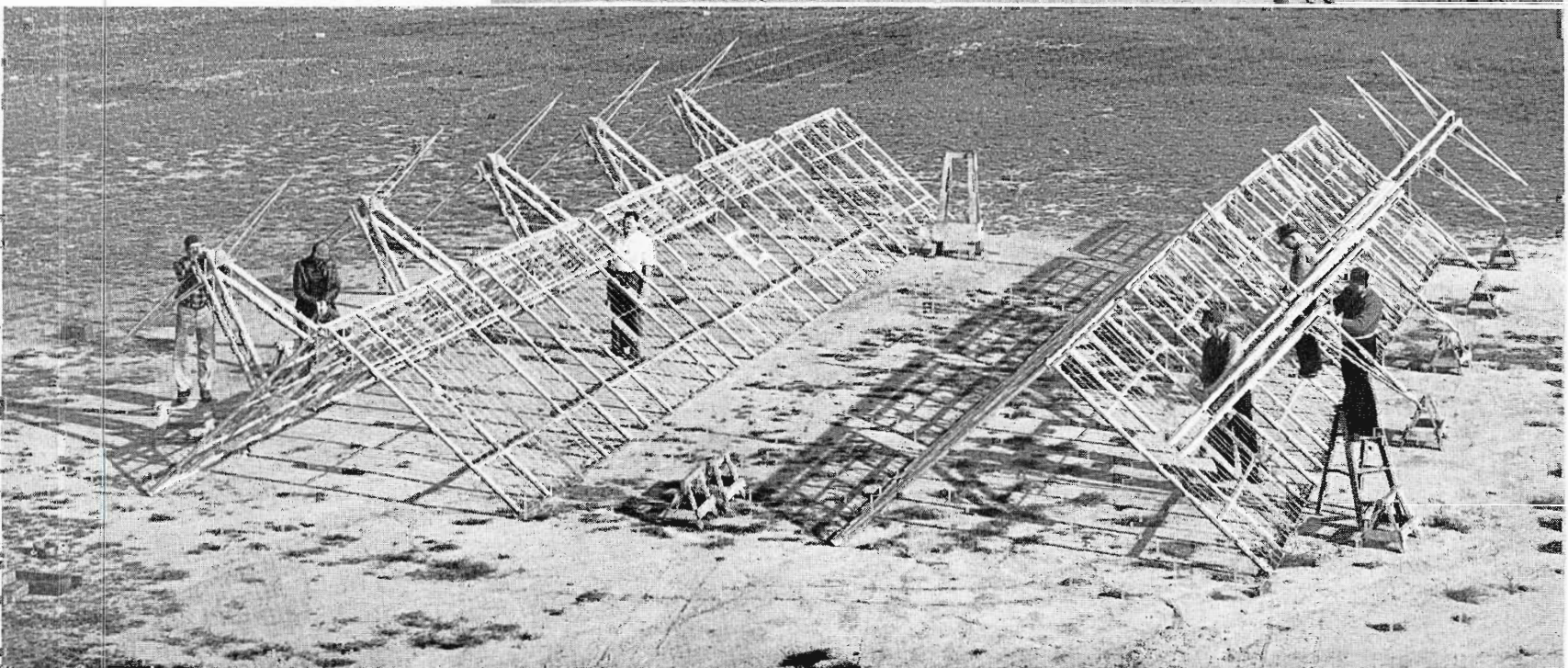

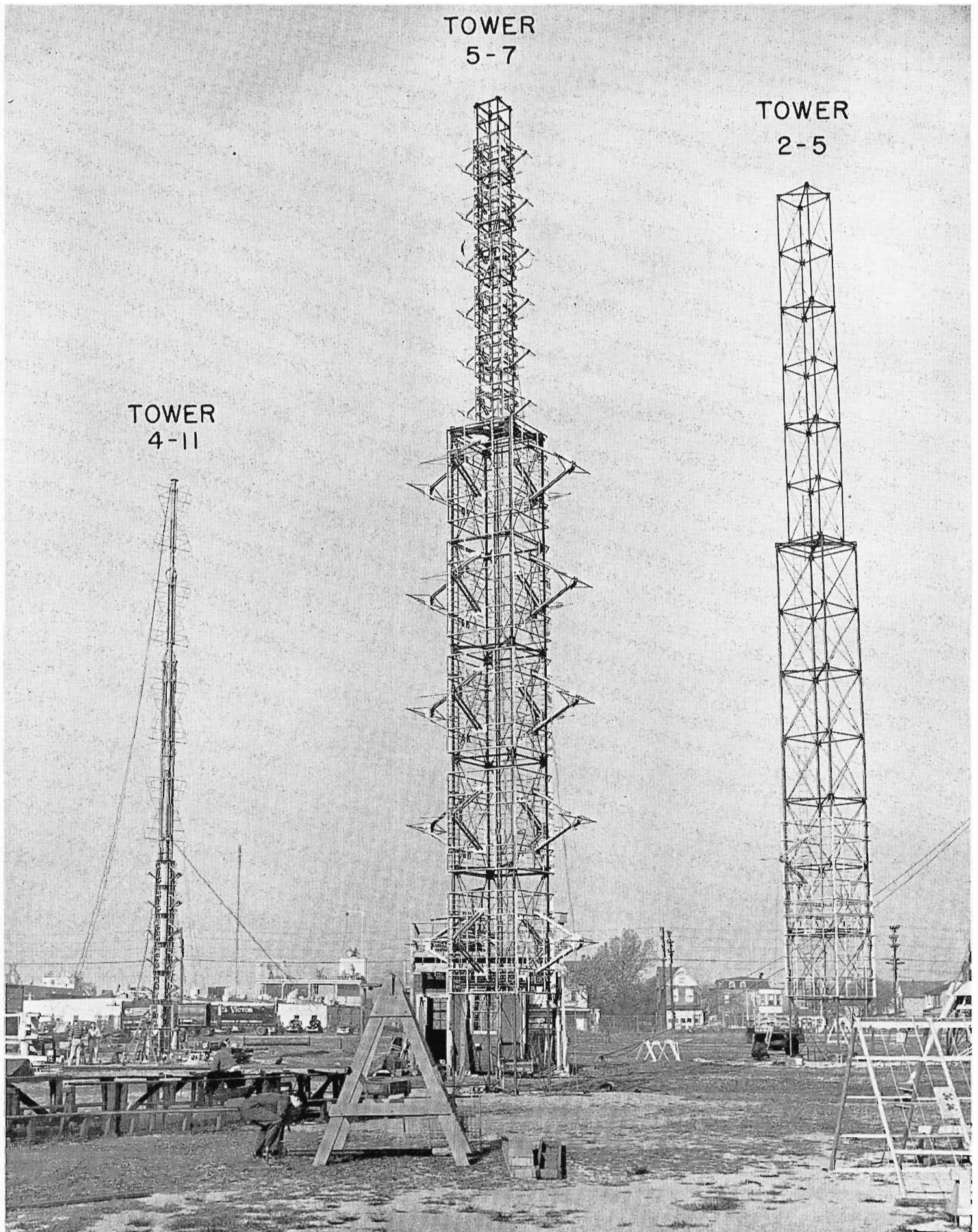
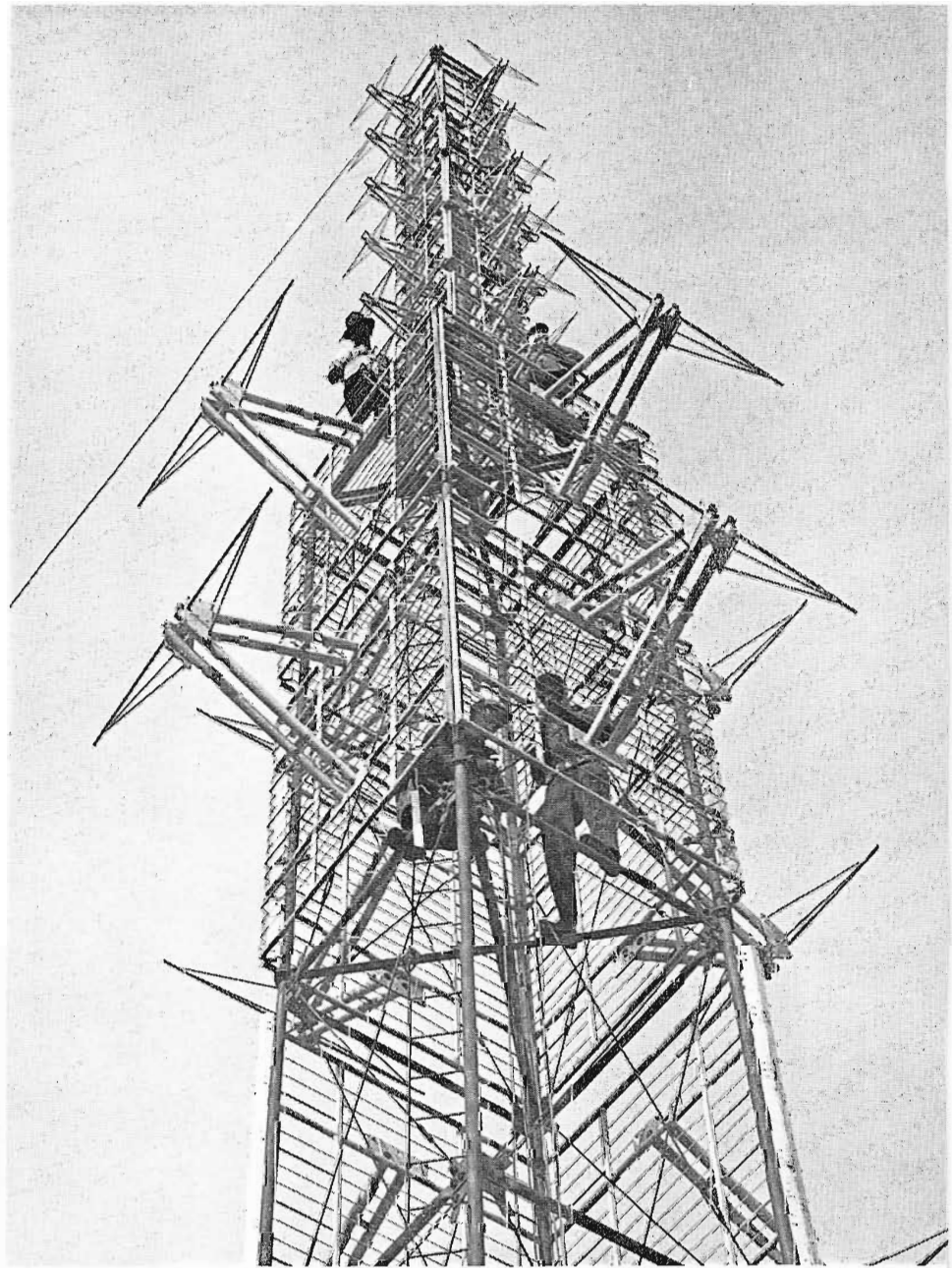

Photo above is a closeup of three of the four towers erected in Camden. The "5-7" tower in the foreground supports the elements for Channels 5 and 7, the "2-5" supports the elements for

Channels 2 and 5, etc. The "4-11" tower consists of both Super Gain (lower) and Super Turnstile sections, since the Channel 4 TV station will utilize a four-section Super Turnstile as radiator.

View looking up tower 5-7. The backing screens assure maximum forward radiation from all four sides of the tower. Super Gain antennas will consist of six vertically-stacked sections for each of the Channels 7 and 11, five sections each for the Channels 2 and 5.



TOWER
7-11



After tests have been completed on the 5-7 and 4-11 towers, the elements for Channels 7 and 11 will be moved to the 7-11 tower shown at left for further interaction tests. Installation of a wye in the transmission lines will permit feeding only part of the antenna for emergency operation.

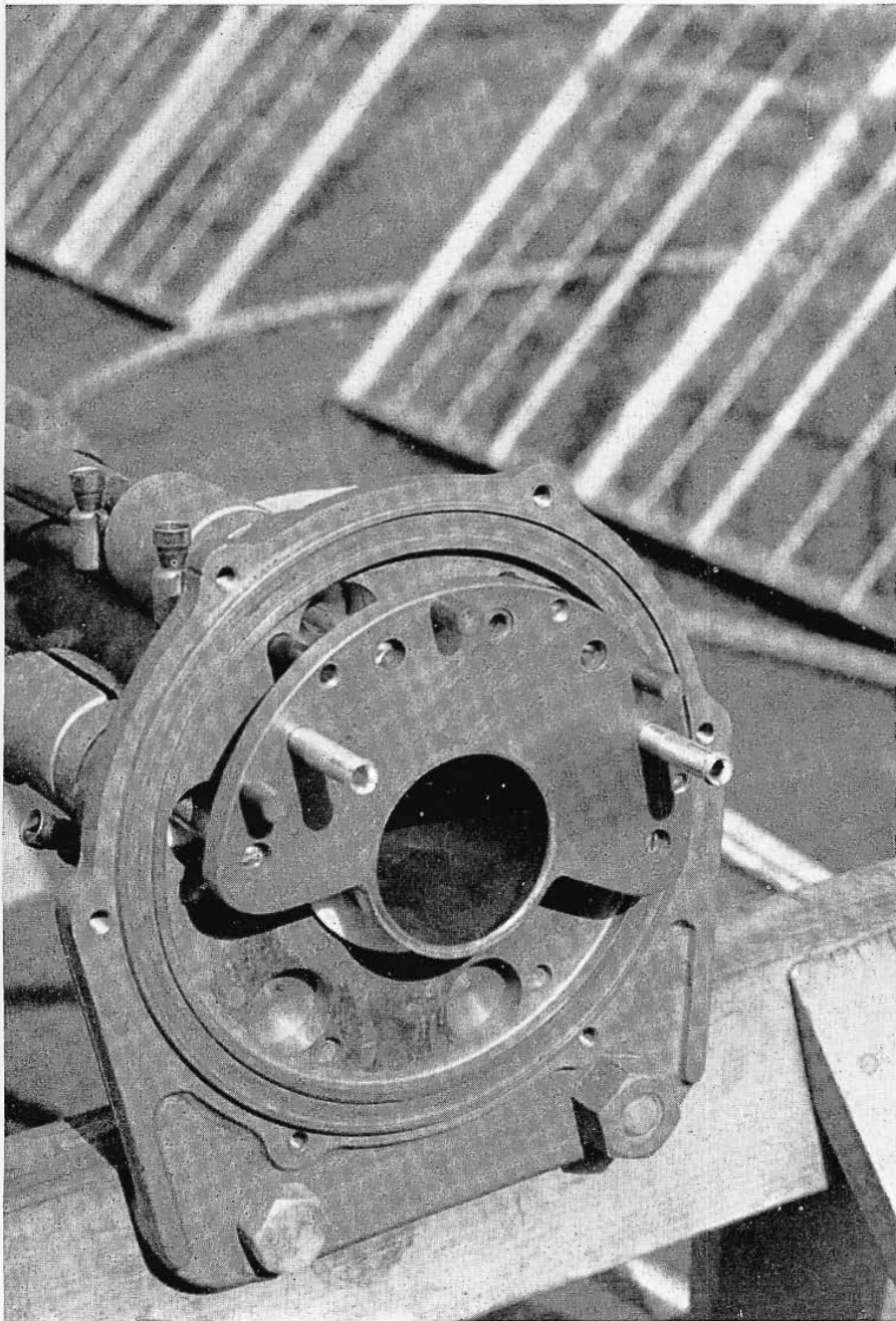

◀ Disassembled junction box shows the method of interconnecting feed lines to the main transmission line which is a 52-ohm air-dielectric coaxial line.

Below is a view of the upper two bays of the Channel 4 Super Turnstile antenna placed on trestles for wiring. Junction boxes mounted on opposite sides of pole receive the RG-35U cables from the eight sections (two for each bay, North-east and South-west). Flanged section below junction box is an impedance transformer.

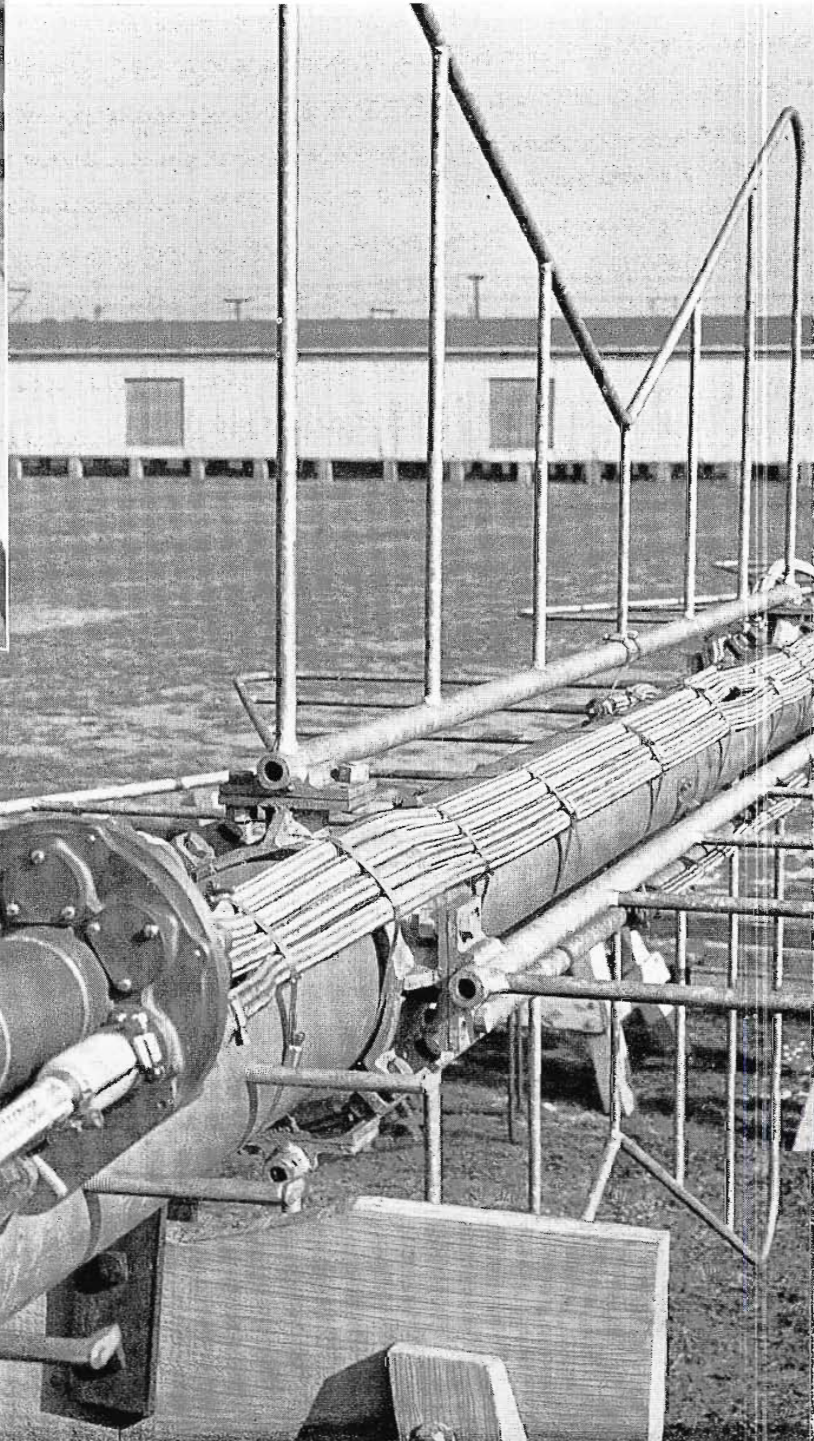

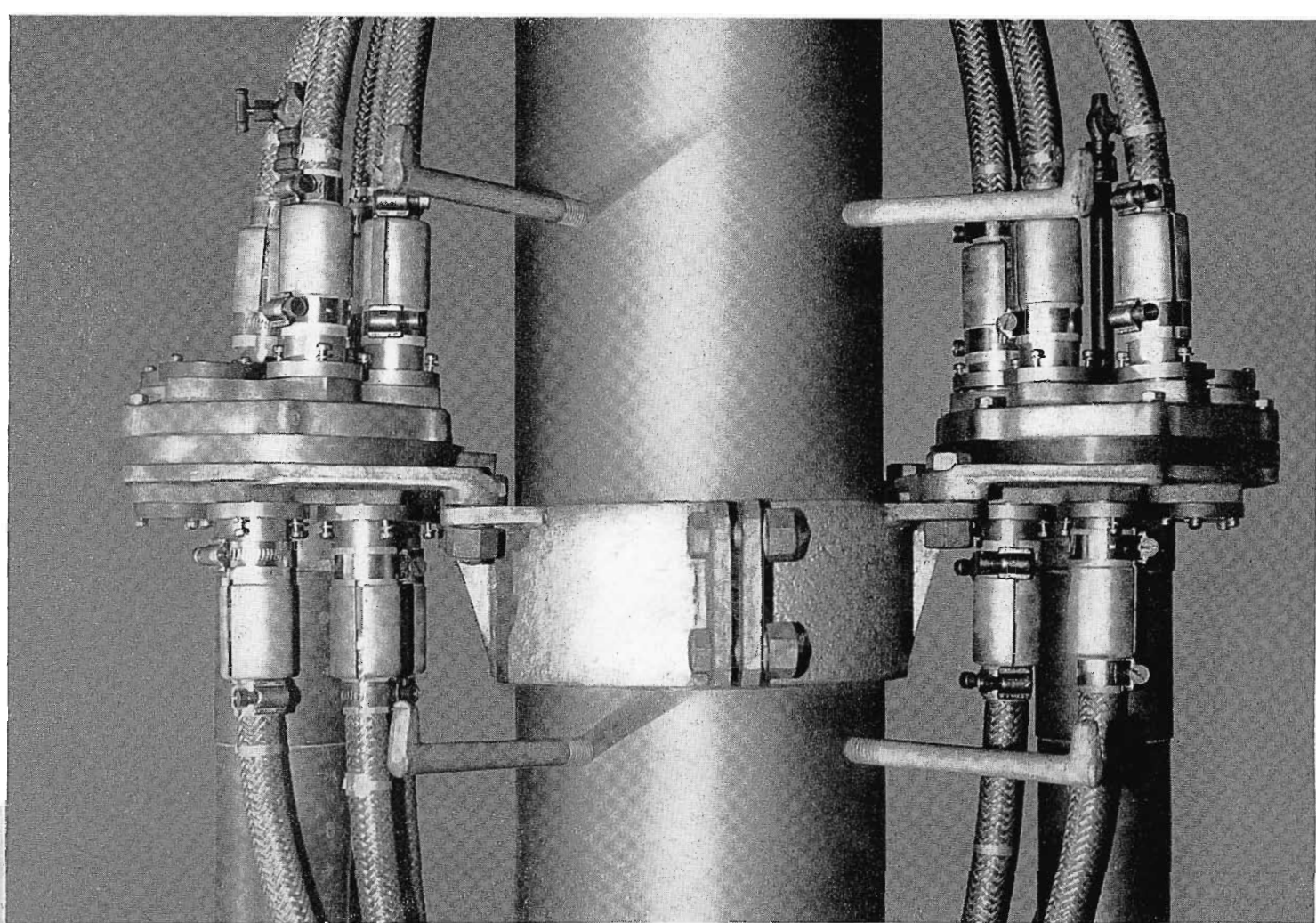

Junction boxes which connect individual feed lines to the rigid coaxial lines shown mounted on supporting pole for Super Turnstile. Junction boxes for Super Gain elements mounted within tower.

The SWR is checked for each individual element (placed in the proximity of other elements), and finally, SWR measurements are made on the main feed line with all elements connected. Below, tests are being made on Channel 7 radiators with Channel 5 elements visible in the foreground.

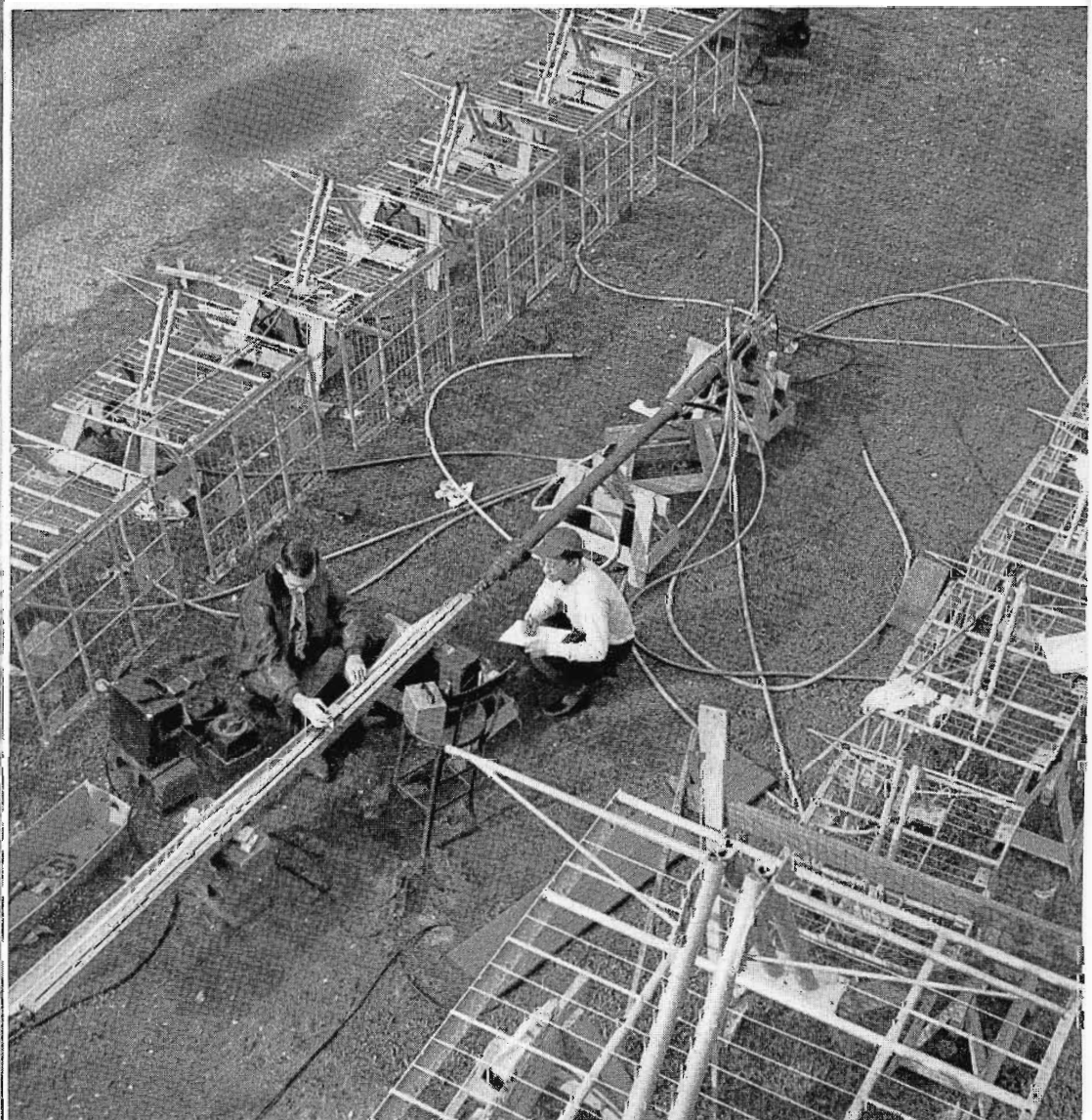
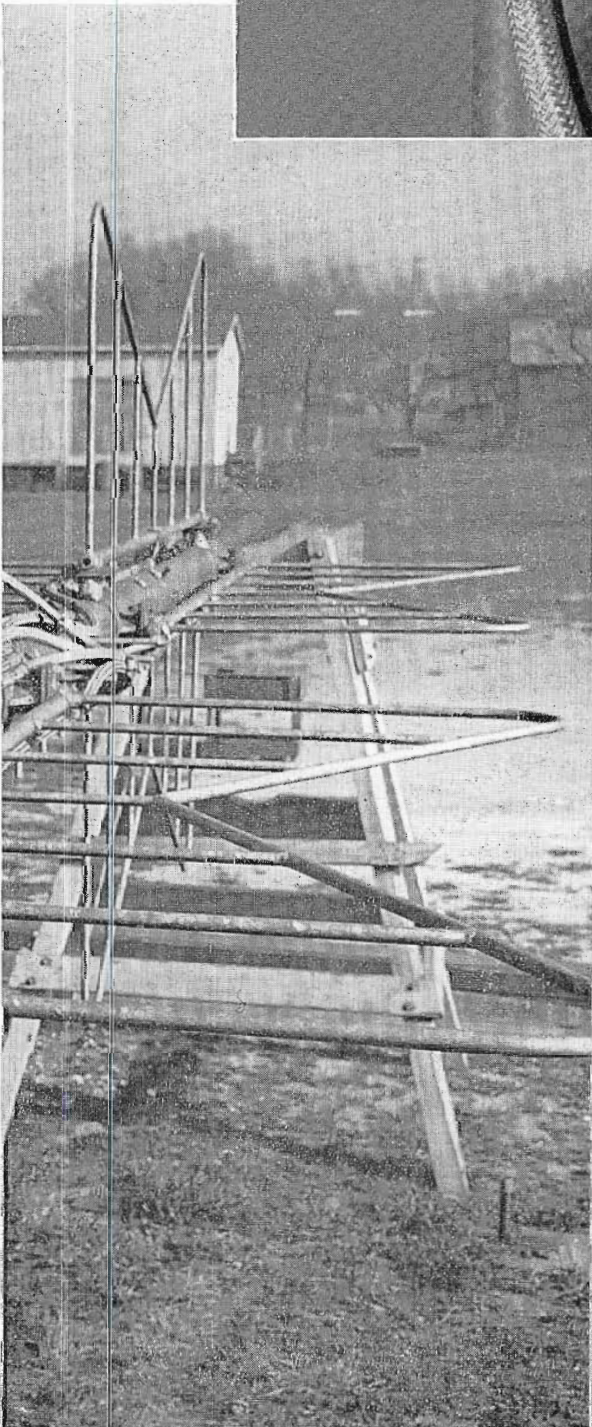

Serving Millions From Atop The Alleghenies

WJAC-TV

*Johnstown
Penna.*

*Channel
13*

Identification slide of Johnstown's only TV station.

WJAC-TV, Johnstown, Penna.

by Nevin L. Straub, Chief Engineer



Mr. Walter W. Krebs, President of WJAC, Inc.

WJAC-TV, located 1600 feet above the city of Johnstown on Laurel Hill Mountain, began commercial operation September 15, 1949. The station is owned and operated by WJAC, Inc., which in turn is 100 per cent owned by the Johnstown Tribune Publishing Company. Also in Johnstown is WJAC, the parent AM station, as well as WJAC-FM. The FM transmitter is located in the mountaintop TV transmitter building. This modern building is 32 feet wide and 60 feet long.

Mr. Walter W. Krebs is President of WJAC, Inc. and to him credit must be given for bringing television to Johnstown. In addition to Mr. Krebs, the staff includes: Mr. L. W. Barnes, Executive Vice President; Mr. Alvin Schrott, TV Manager; Mr. Frank Cummins, Program Director; Mr. Nevin L. Straub, Chief Engineer; and Mr. Theodore (Ted) Campbell, Assistant Chief Engineer.

WJAC-TV operates on Channel 13 and due to its extreme height (antenna 2872

View of WJAC tower taken during erection of TV Super Turnstile on top the Pylon FM antenna.

feet above sea level, 1120 feet above average terrain) the FCC limited the ERP to 6.5 kilowatt visual and 3.7 kilowatt aural. This unusually low ERP could be obtained by using either a 500-watt transmitter and a high gain antenna or a 5-kilowatt transmitter and a relatively low gain antenna. The latter course was chosen as it provided for future expansion; also it was thought that a broader radiation pattern in the vertical plane would be of help to fill the valleys of the extremely mountainous terrain in and around Johnstown. A two-bay RCA Super Turnstile Antenna was chosen as the radiator.

TV Facilities

The equipment and layout of equipment was selected to require a minimum of operating personnel, while at the same time provide a high-quality, professional-type operation from the TV viewer's standpoint. The transmitter operating console, the program switcher (MI-19063), preview monitor and FM audio control were placed side by side in order that the trans-

Photo below is a view from WJAC-TV tower of AT & T New York to Chicago microwave link (structure at right). WJAC-TV was interconnected to this network link in June of this year.

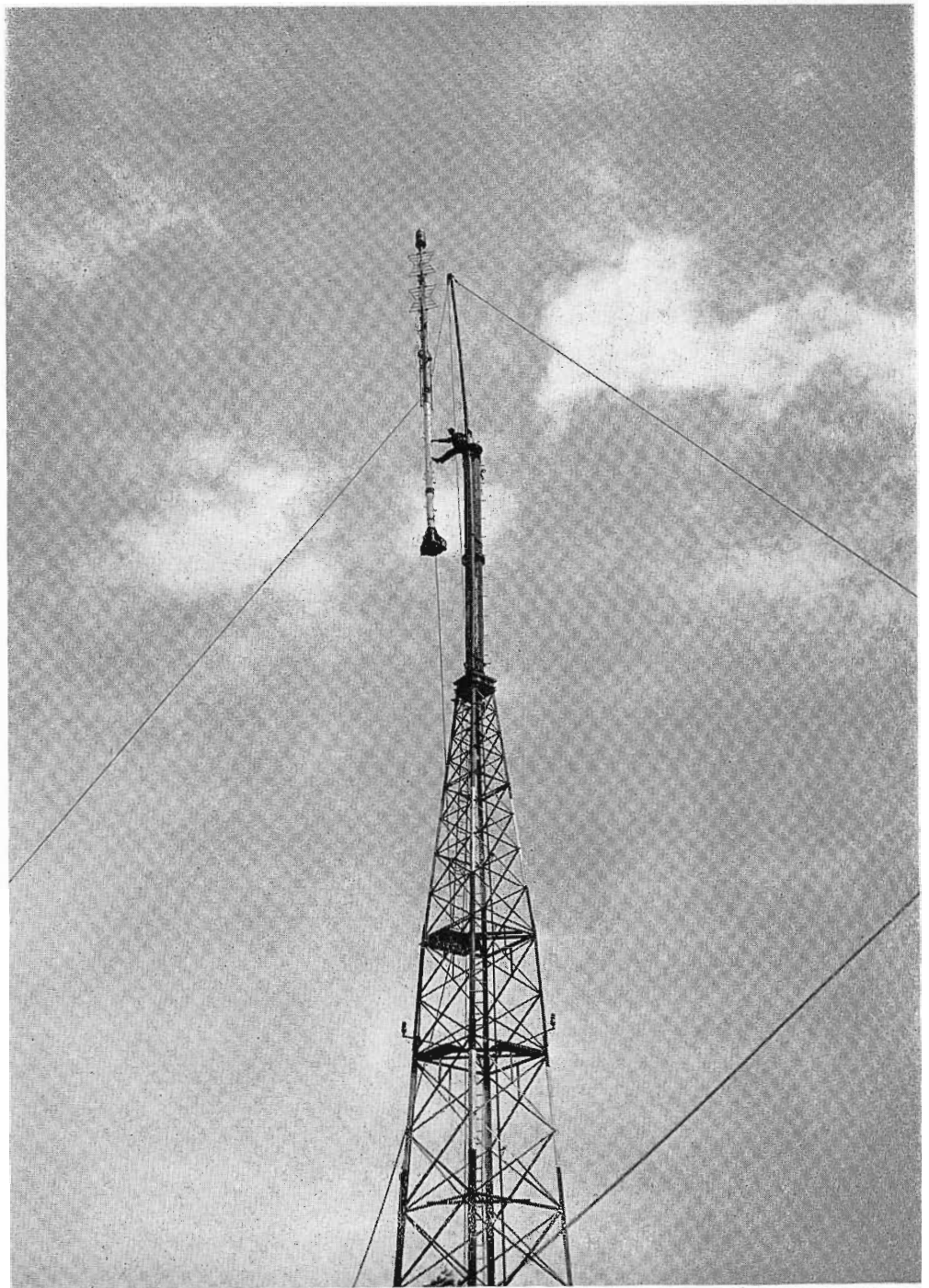

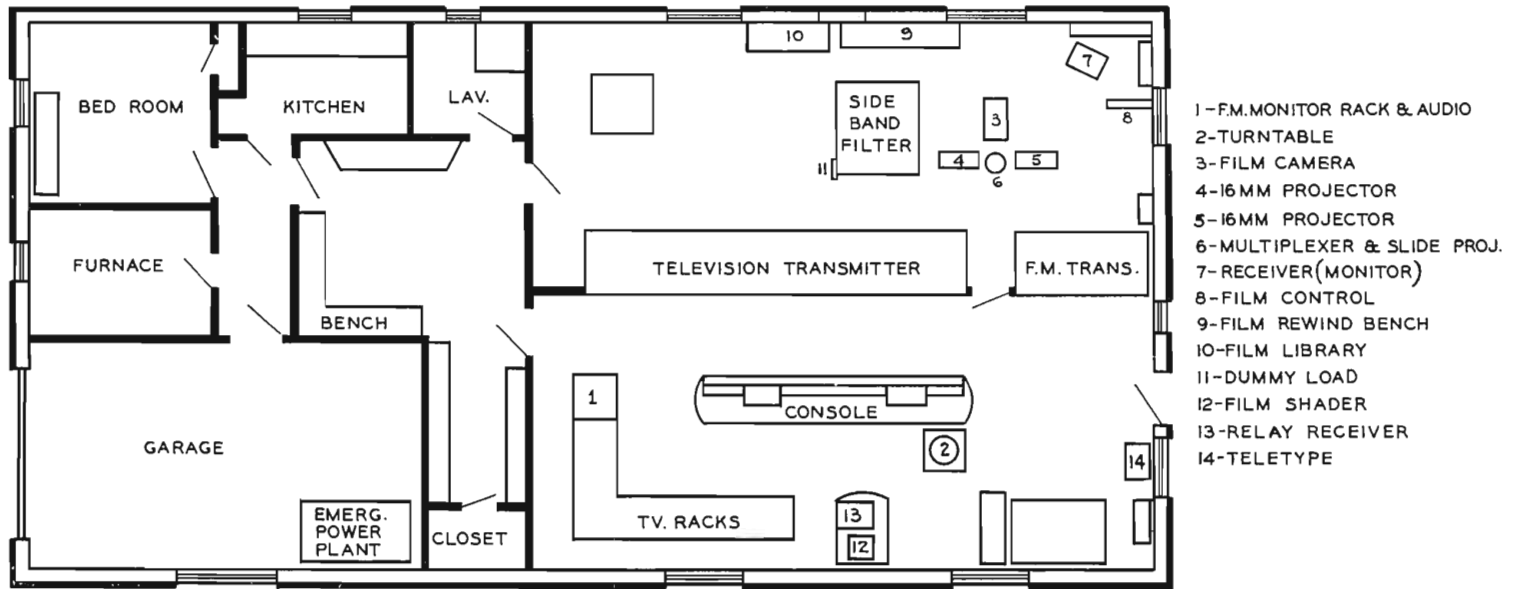

Diagram above is a floor plan layout of the WJAC-TV transmitter building. The transmitter console combines FM, TV and program control functions as described in the text.



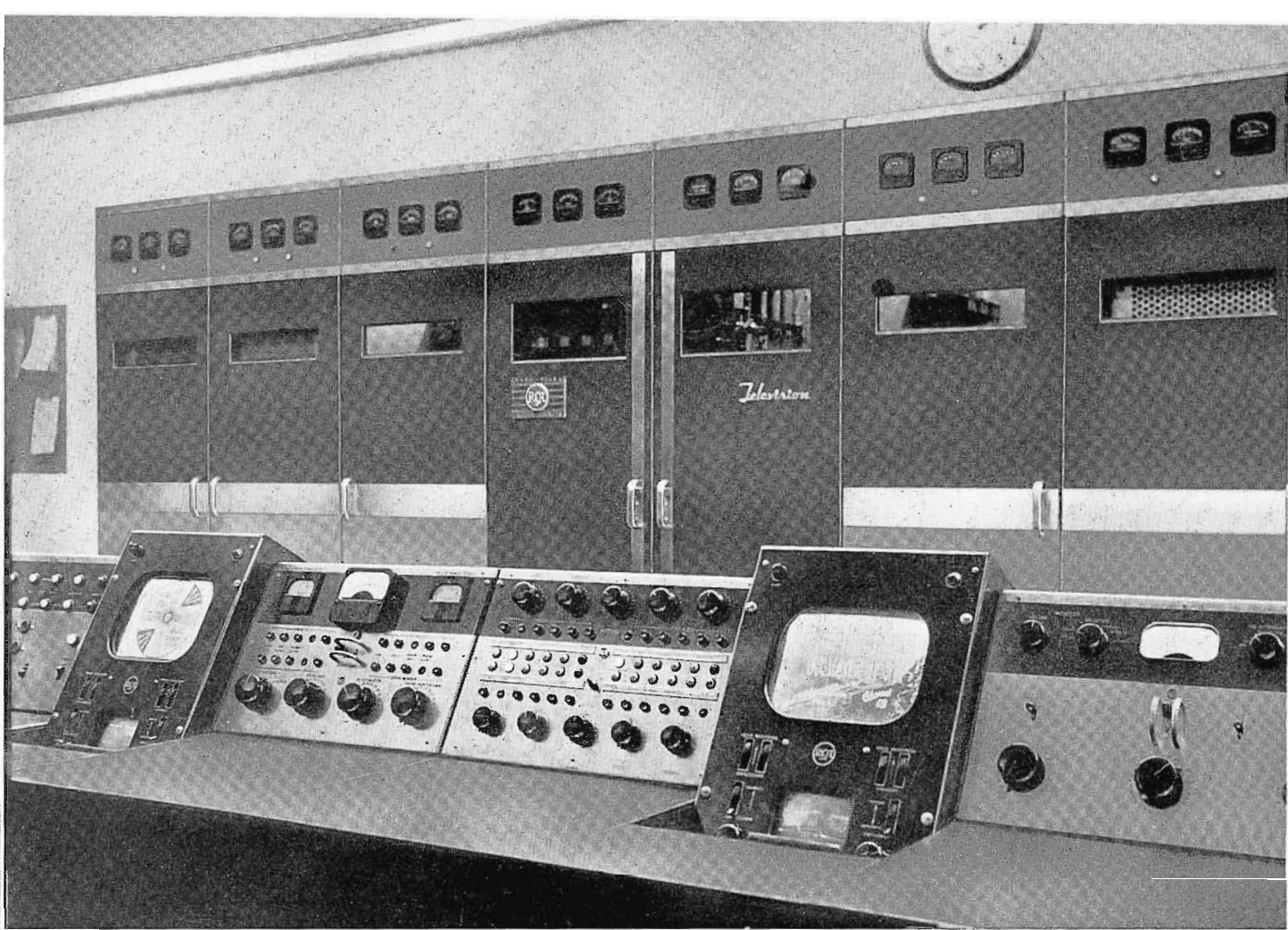
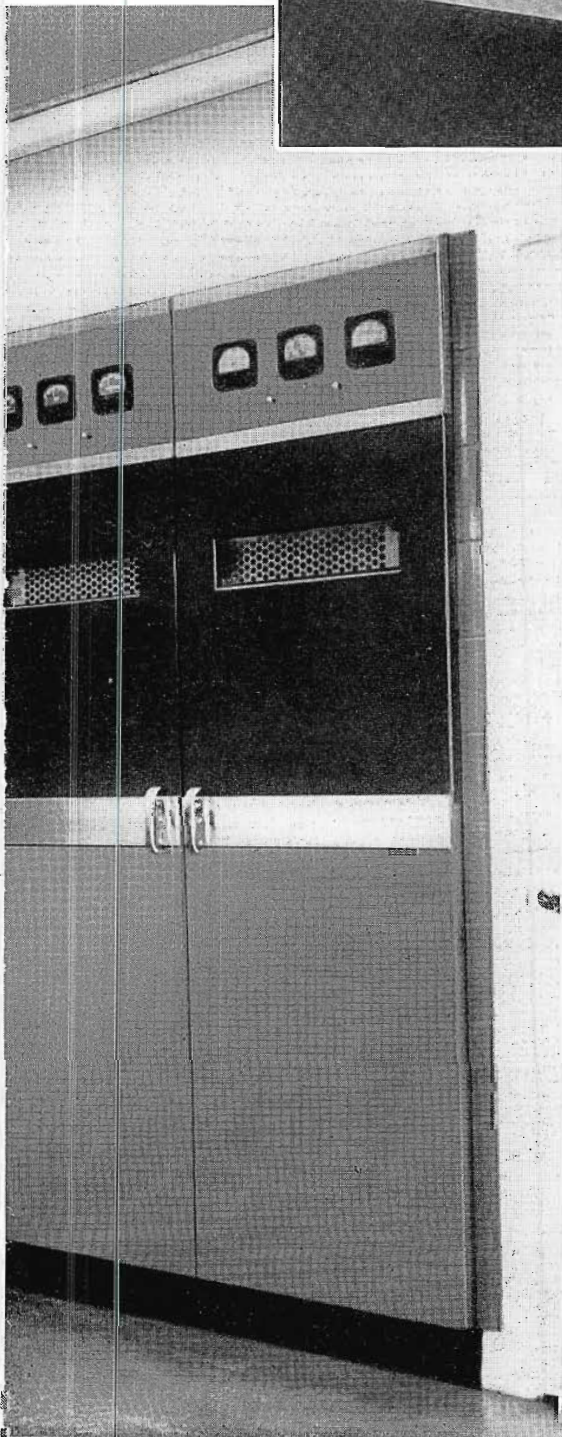

Photo above gives a better view of the FM-TV transmitter console, and TV program switching turret (center of photo). FM turret is at extreme right, TV transmitter monitor and control turrets at left. Right hand monitor unit is for program preview.



mitter operator would be available during switching periods, while at the same time he could watch the transmitters and keep his two FCC transmitter logs. A second man, the technical director, is also present at the main control console during program time. The technical director is responsible for cueing the projectionist and the switcher, and in general, overseeing the operation from a program point of view. The film shading console is separate from the main control console, in order that the film shader may concentrate on the shading operations. These are particularly important during station breaks when different spots and slides are flashed on the air.

Film projection equipment which consists of two 16mm projectors, a film camera and multiplexer is located to the rear of the transmitter. The film camera is mounted on a special swivel device so

that it can be swung from the multiplexer and slide projector to a balop for opaques.

MI-19063 Audio-Video Switching Turret

The MI-19063 Audio-Video switching system is a turret only, but it is designed for mounting in a desk section



Mr. Nevin L. Straub,
Chief Engineer of WJAC-TV.

Transmitter room of WJAC-TV showing the RCA 5-kw TV transmitter and control console. Transmitter console shown here includes standard RCA TV console plus additional sections for FM transmitter control and TV program switching.

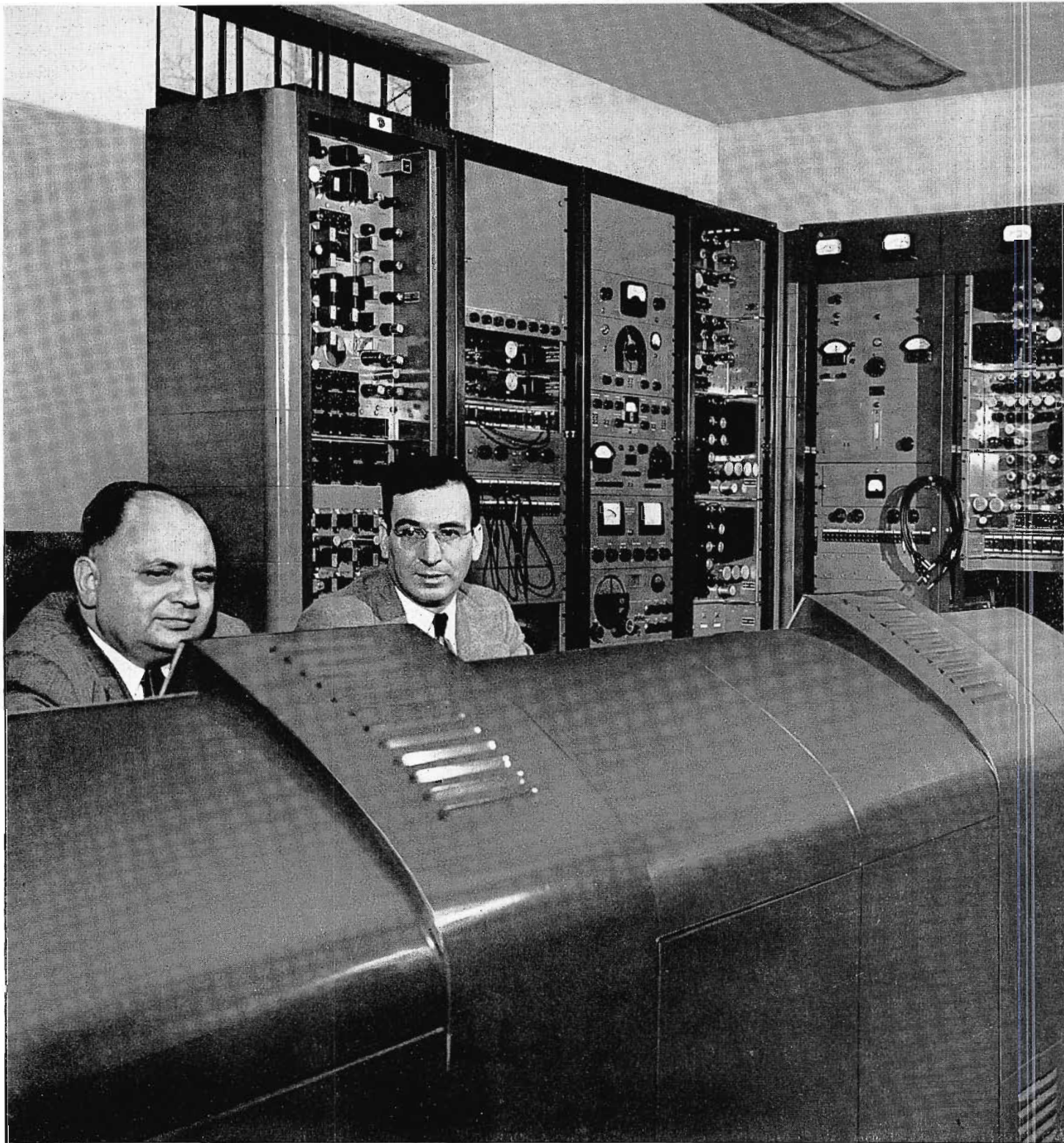

View from opposite side of transmitter room showing equipment racks arranged in one corner. Equipment consists of sync generator (left hand rack) audio and video patch panels, input and monitoring equipment, power supplies. Seated at the console with Nevin Straub is Ted Campbell, Assistant Chief Engineer.

(MI-28401-1) so that it can be used in conjunction with a master monitor for previewing. The system incorporates fader controls for adjusting video levels, for program and preview. The block diagram on the opposite page shows how the turret is employed at WJAC-TV. Stabilizing Amplifiers and Mixing Amplifiers are used for mixing and fading of video signals. Distribution Amplifiers, which can be mounted in the desk, are used for isolation.

All switching is accomplished by push-button switches arranged so that the normally associated picture and sound push buttons are one above the other and can be operated simultaneously with one hand. However, the switches are independent; thus sound and picture can be switched separately if desired.

Audio Circuits

Five audio push buttons are arranged so that any one of them can be operated

to feed its signal to the output. The #5 position, intended for a microphone, can be mixed with the signal from #1, #2, #3 and #4, or used alone as desired. Each audio channel includes a 20-step gain control with 2 db steps tapered to infinity. Audio input and output impedances are 600 ohms, balanced. OFF push buttons remove all signals from the output. Audio circuits are electrically interlocked, giving the program circuit priority over audition

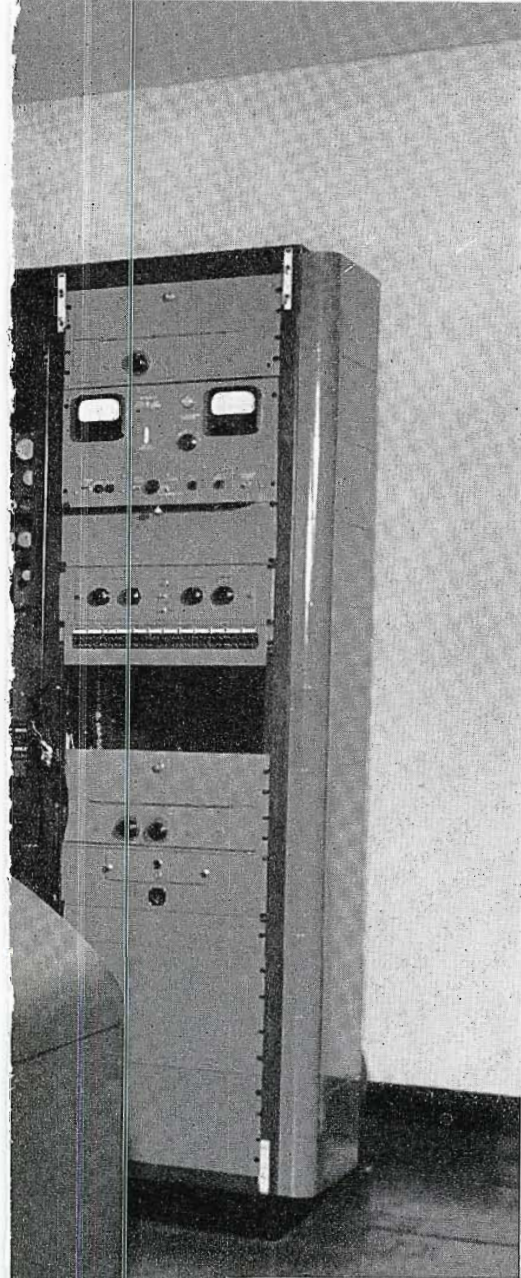

circuits. Headphones can be used for auditioning the signal by use of a jack supplied for mounting below the desk top. A minimum of -20 dbm audio input level is required.

Video Circuits

Five video circuits are arranged to receive signals from external preamplifiers (one for each program source), and select signals desired for preview and program uses. Three of the five video channels are designed for use with Stabilizing Amplifiers, Type TA-5B (or TA-5C with slight turret modifications). These channels, which require a video input of 0.15 to 2.0 volts peak, are normally used for remotely generated composite signals, but they can be used to mix sync with local signals if necessary.

The other two channels are designed for use with mixer amplifiers, Type TA-10A, and can be used for local signals where

sync and video are available separately. They require 2.0 volts $\pm 25\%$ video signal, and 4 volts sync signal. The preview and program video circuits are completely isolated. Two identical outputs are obtained from each preamplifier and connected to the turret through 75-ohm coaxial cable. In the turret, each cable is terminated by a special isolating network. This network permits switching of any of the five video inputs to a Distribution Amplifier mounted in the desk, without the loss of high frequency response. One channel of the five-channel Distribution Amplifier supplies the preview monitor, two channels provide signals for the transmitter and transmitter input monitor, and the remaining two channels provide signals for the preview channels #4 and #5.

Although not shown in the block diagram on this page, another source of video was added by WJAC-TV's interconnection with the network cable early this year.

Block diagram of WJAC-TV video facilities. Turret MI-19063 is the program switching unit which is mounted in the transmitter control console. Other connections not shown on the diagram are the network line from AT & T, and a line from the grating generator.

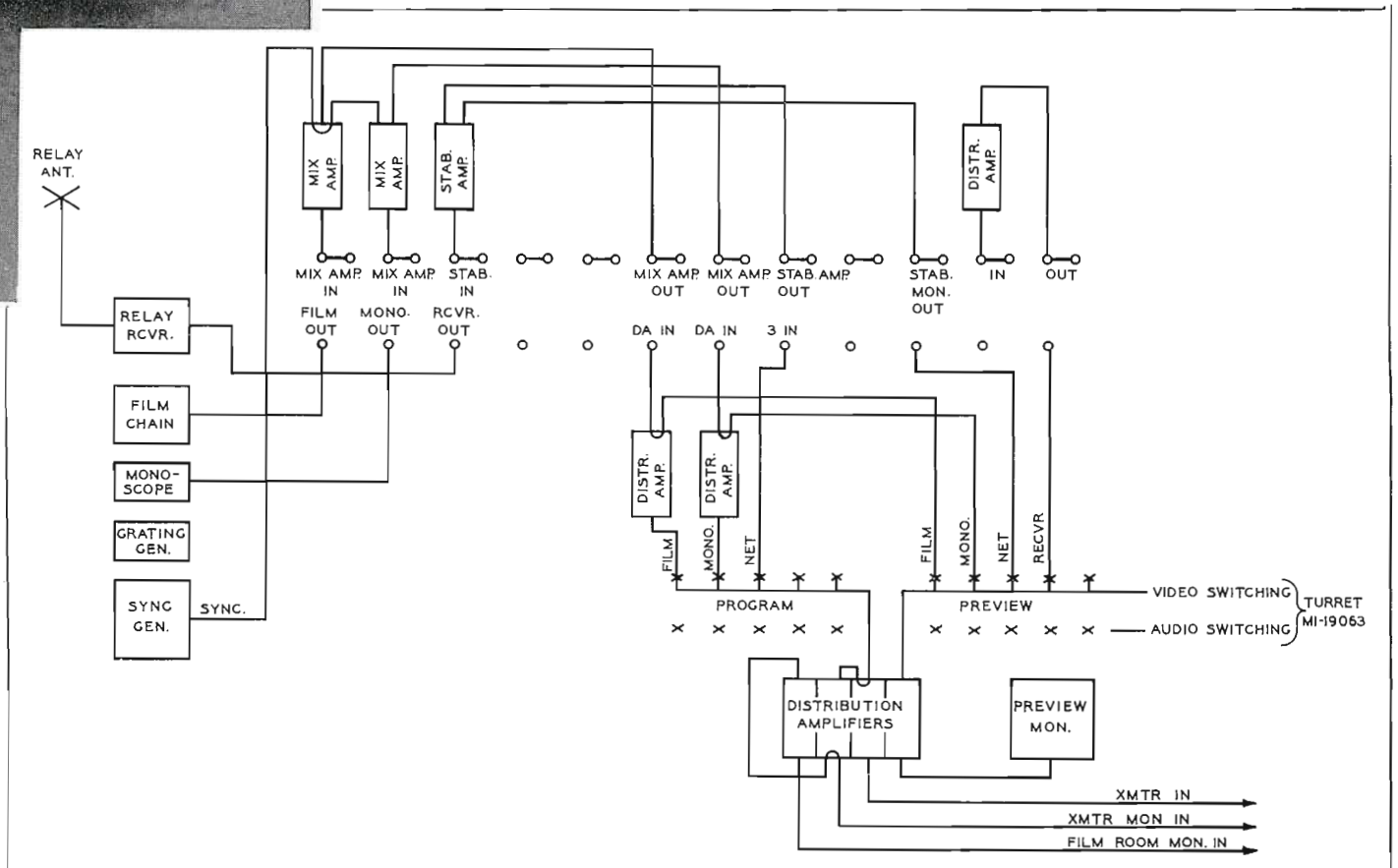

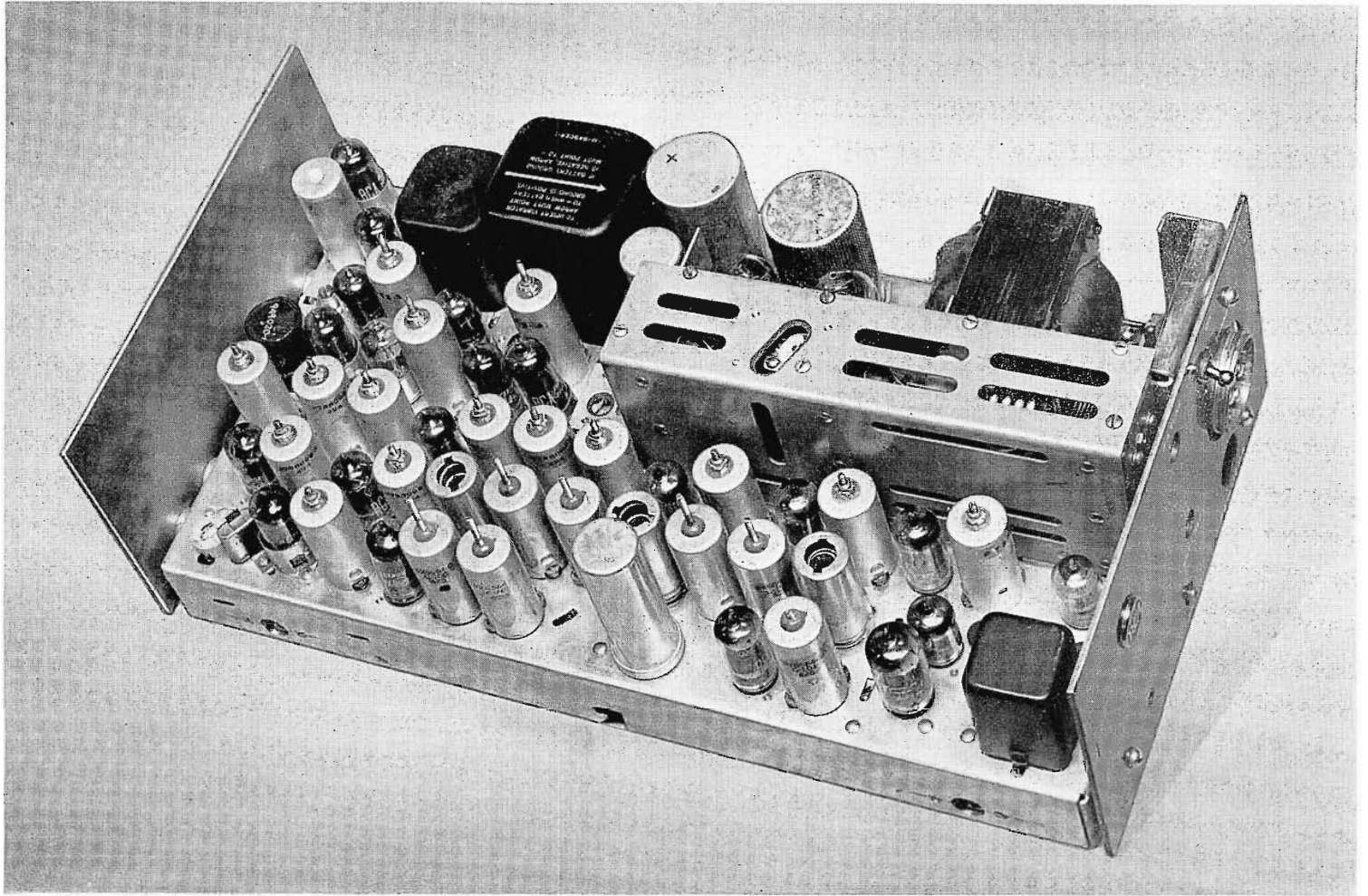

FIG. 1. The 15 watt RCA Carfone shown above, was the first adjacent channel two way radio equipment on the market. Completely open, accessible construction puts every component and every connection "on top". The unit can be removed for service in thirty seconds.

DESIGN OF MOBILE TWO WAY RADIO COMMUNICATION EQUIPMENT AT 152-174 MC.

By **R. A. BEERS, W. A. HARRIS, A. D. ZAPPACOSTA**

Mobile Communications Engineering, RCA Engineering Products Department

Broadcasters have been well acquainted with the use of two way radio for many years. Mobile two way radio equipment has been used with great success as a standby line and for covering remote pick-ups where telephone lines have not been readily available. This medium of communication has also been used with great success by police departments as early as 1931. As more people realized the convenience of radio, the number of users increased and the FCC was literally deluged

by applications for frequency assignments. The 152-162 megacycle band was opened on an experimental basis to the land-mobile services, and its utilization was so rapid that all available channels for assignment quickly reached the exhaustion point in many localities. This band had been set up on the basis of 60-kc channels and a block of continuous channels was designated for each type of service. Actual assignments were on an alternate channel basis in the same locality.

With alternate channel operation in the same locality, it was not long until considerable interference between stations was encountered. Some of this interference was caused by insufficient alternate channel selectivity in the intermediate frequency portion of the receiver. In other instances where the intermediate frequency selectivity was adequate, the receiver front end selectivity was insufficient and the receiver became desensitized by a strong

alternate channel signal and hence could not receive the desired signal.

In areas where three or more alternate channel services were simultaneously in operation, a type of interference was encountered which was not anticipated. The alternate and next alternate channel signals mixed in the receiver front end, and produced a third signal whose frequency was exactly the same as that to which the receiver was tuned.

Example:

Desired signal frequency = 152.00 megacycles

First alternate signal frequency = 152.120 megacycles

Second alternate signal frequency = 152.240 megacycles

$2 \times 152.120 = 304.240$
152.240

152.000 megacycles the
desired frequency

The same condition also exists if the two unwanted signals are 120 and 240 kc respectively, below the desired frequency.

Mathematical exploration showed that this condition, which now is generally called intermodulation interference, existed because of third-order plate characteristic curvature of the receiver radio-frequency amplifier tubes and fourth-order plate characteristic curvature of the mixer tube, and laboratory work pointed to the fact that the mixer tube was the worst offender. It was found that two transmitters located closely together and separated by 120 kc in frequency also would produce and re-radiate off-frequency signals, both above and below their actual frequency, whose frequency would be their carrier frequency plus or minus the frequency difference between the two transmitters. Transmitter intermodulation usually is much less serious than receiver intermodulation, unless the two transmitter antennae are located very closely together.

As the use of the service grew beyond expectations, it was soon apparent that more channels would become a necessity, particularly in the metropolitan areas. Adjacent channel operation in the same locality would double the number of channels, but was considered impractical for one or more of the following reasons:

1. Difficulty of obtaining the required selectivity and over-all stability.

2. Transmitter modulation products and spurious radiations must be materially reduced.

3. Receiver intermodulation.

4. Size of mobile equipment to give desired performance.

5. Equipment cost.

Before adjacent channel operation was discarded as impractical, a thorough investigation of the matter was undertaken to determine if the problems involved could be adequately solved.

FIELD TESTS

Preliminary Operational Tests

Extensive field tests were carried out with transmitters of various power rating from 2 to 30 watts under conditions of favorable terrain and in various industrial sections such as Philadelphia, Pa., and Camden, N. J., to determine what power was needed in the transmitter and what sensitivity was required of the receiver. Data collected on the Radio Manufacturers Association's recommendation was gathered on the maximum temperature and

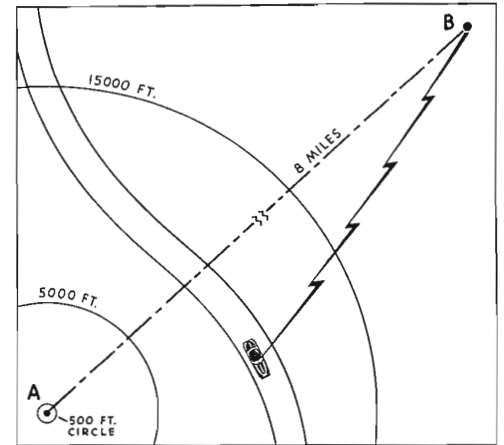

FIG. 2. Benefits of the Carfone's high selectivity are most effectively demonstrated where stations, which have overlapping areas of signal coverage, are assigned adjacent channels. Greater selectivity makes it possible for the RCA mobile equipment to maintain interference-free communications over a much greater area in the region of the overlap. Actual test showed that the RCA Carfone could operate within 500 feet of an adjacent channel station without interference while other equipment had interference radius of 5,000 to 20,000 feet. The new 30 watt Super-Carfone, shown below, operates efficiently within A FEW FEET of adjacent channel station.

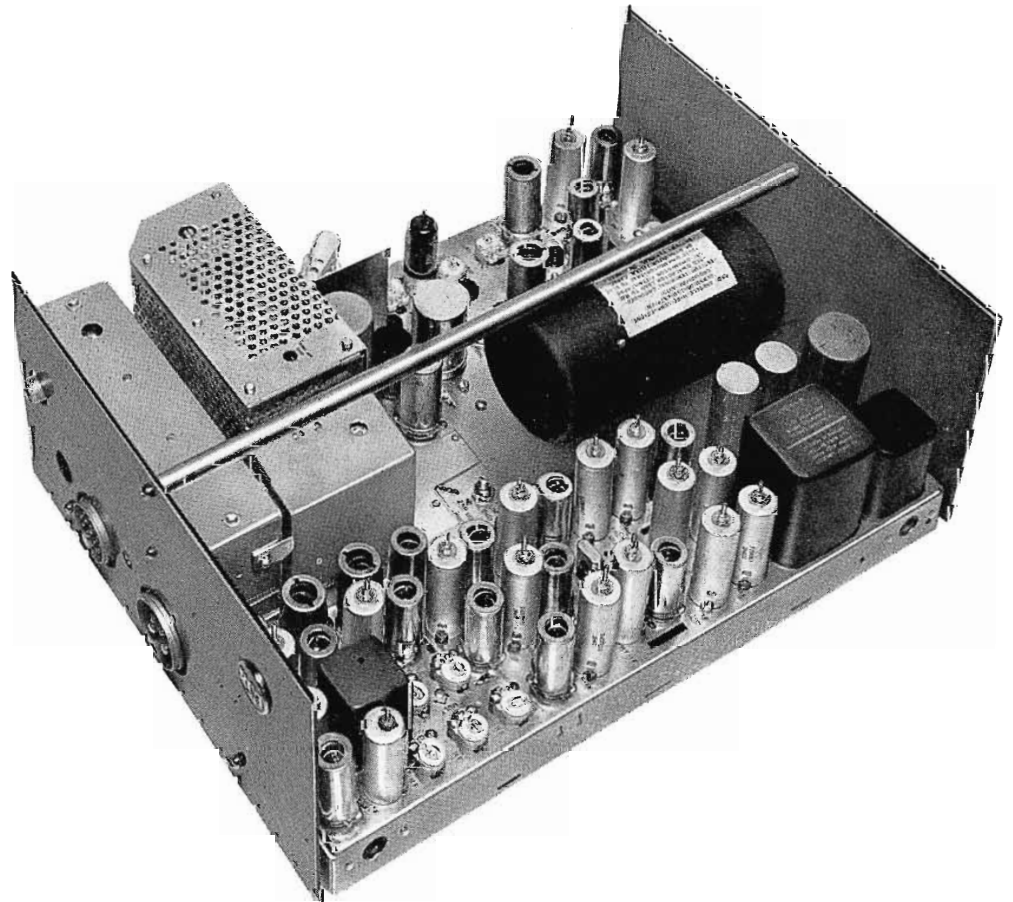

FIG. 3. The 30 watt RCA Super-Carfone, introduced recently, provides excellent performance in crowded metropolitan areas as well as farther out in the suburbs where the going is tough. Unique grounded-grid r-f input circuit provides high receiver sensitivity and simplified tuning.

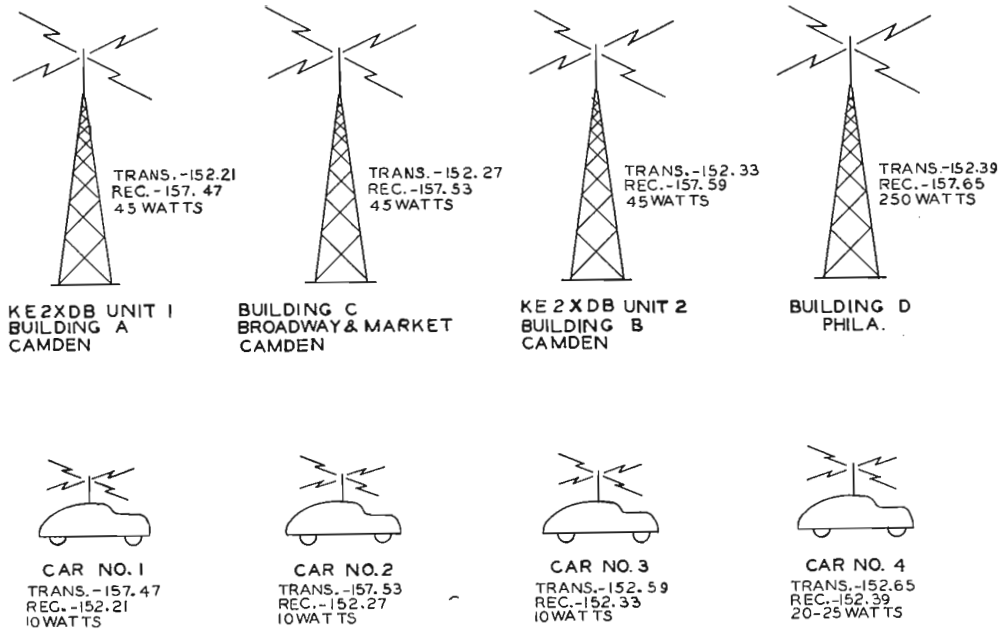

FIG. 4. Four separate stations transmitted on adjacent channels during the series of tests.

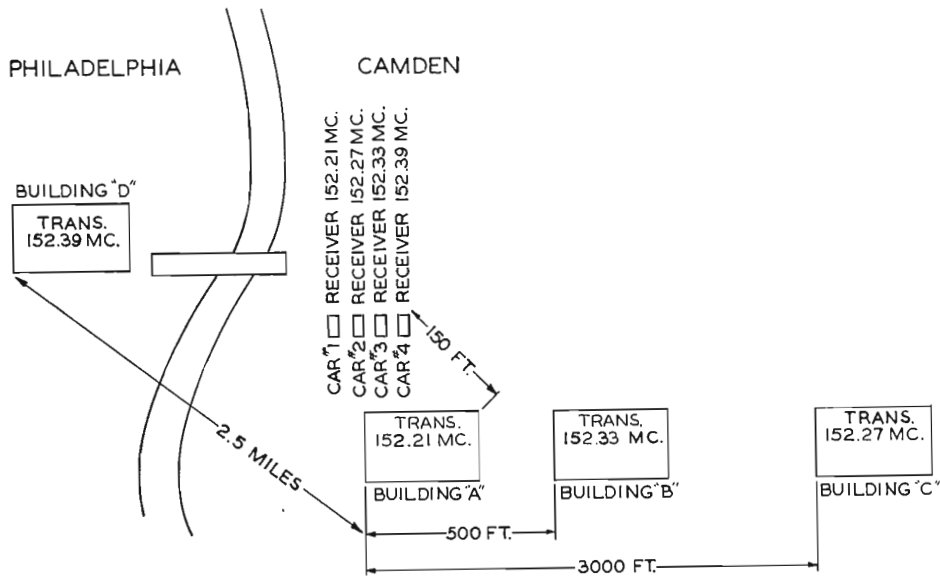

FIG. 5. Diagram shows location of mobile and land station during four channel test Number One.

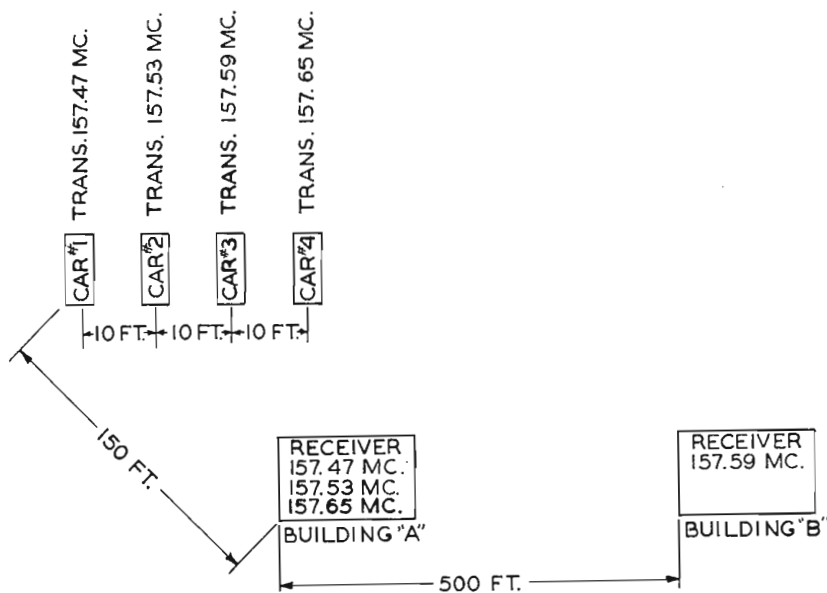

FIG. 6. During the second test of four adjacent channel operation with RCA mobile car radios on air, signals heard in each car were free of interference.

humidity conditions to be expected anywhere in North America. Calculations and some field tests were made to determine the maximum adjacent channel signal strength to be expected from a land station of 250-watt power in a mobile receiver to determine the required receiver adjacent channel selectivity. This was necessary so that the mobile receiver would be able to receive a weak desired signal when located very close to a powerful land transmitter. Adjacent channel field tests were run using a very selective receiver to determine the degree of modulation control required to allow practical adjacent channel systems. Tests were run with a number of different persons, both male and female voices, under widely varying conditions of ambient noise with abrupt changes in sound level to evaluate the performance of various modulation limiters for the transmitter.

Two Adjacent Channel Tests

Two 45-watt land station transmitters, designated as *A* and *B*, with a carrier separation of 60 kc, were operated simultaneously, see Fig. 2. The $\frac{1}{4}$ wavelength ground-plane antennae for both stations were approximately 100-feet high.

Using mobile equipment available in late 1948, the mobile receiver was interfered with to such an extent that the desired signal was "captured" by the non-desired signal whenever the mobile car was within one to three miles of the adjacent channel 45-watt land stations. The new mobile receiver was able to listen to the desired frequency without interference up to 250 feet or less of the adjacent channel 45-watt transmitter.

Four Adjacent Channel Tests

In order to best simulate normal operating conditions, the tests were run in conjunction with two commercial services that were already in operation. These services were the Yellow Cab Company of Camden, N. J., and the Bell Telephone Company of Pennsylvania.

The equipment in building *C* was operating on 152.27 megacycles and 157.53 megacycles, while building *D* was on 152.39 and 157.65 megacycles. Experimental transmitters were placed in opera-

tion on 152.21, 152.33, 157.47, and 157.59 megacycles. This resulted in four adjacent channel systems, each having two frequencies. The test is shown in Fig. 4.

In the first test that was run, the four mobile units were parked in front of building A which housed one of the transmitters. The four land station transmitters were separated from the mobile receivers by 100 feet, 1½ blocks, 7 blocks, and 2½ miles respectively. All four of the mobile receivers responded with clear and interference-free reception. A sketch of this test is shown in Fig. 5.

In the second test the procedure was reversed and the mobile transmitters were put on the air. The equipment in building B was remote controlled so that the signals could be heard in building A, and station receivers were installed on the two commercial channels with antennae on building A. In this way all of the mobile transmitters could be heard from one building. The second test was as successful as the first in that signals heard in each receiver were free from interference. The sketch of this test is shown in Fig. 6.

The outstanding improvements in intermodulation response of these receivers were observed in the third test of the series. Mobile units numbers 2 and 3 were placed 0.4-mile from building A and mobile units numbers 1 and 4 were placed 5 miles away.

FIG. 8 (at right). Schematic shows a portion of the receiver intermediate frequency amplifier.

FIG. 9. The 30 watt Carfone, shown below, is a compact transmitter-receiver built into a single steel case which can be mounted in any convenient place in the vehicle. The loudspeaker, microphone, control unit and an antenna unit (not shown), are provided with the equipment.

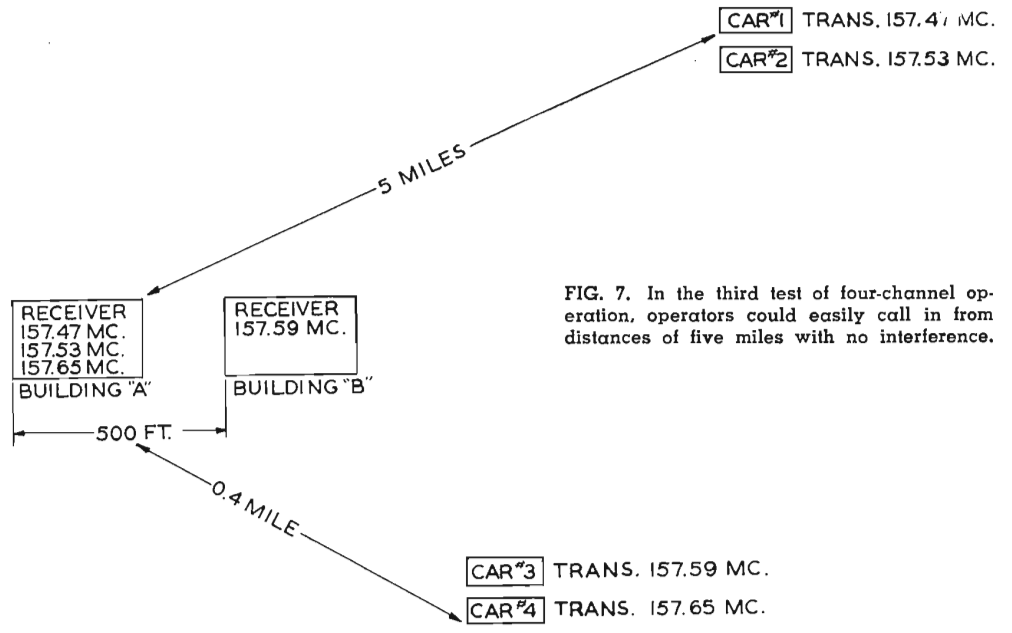
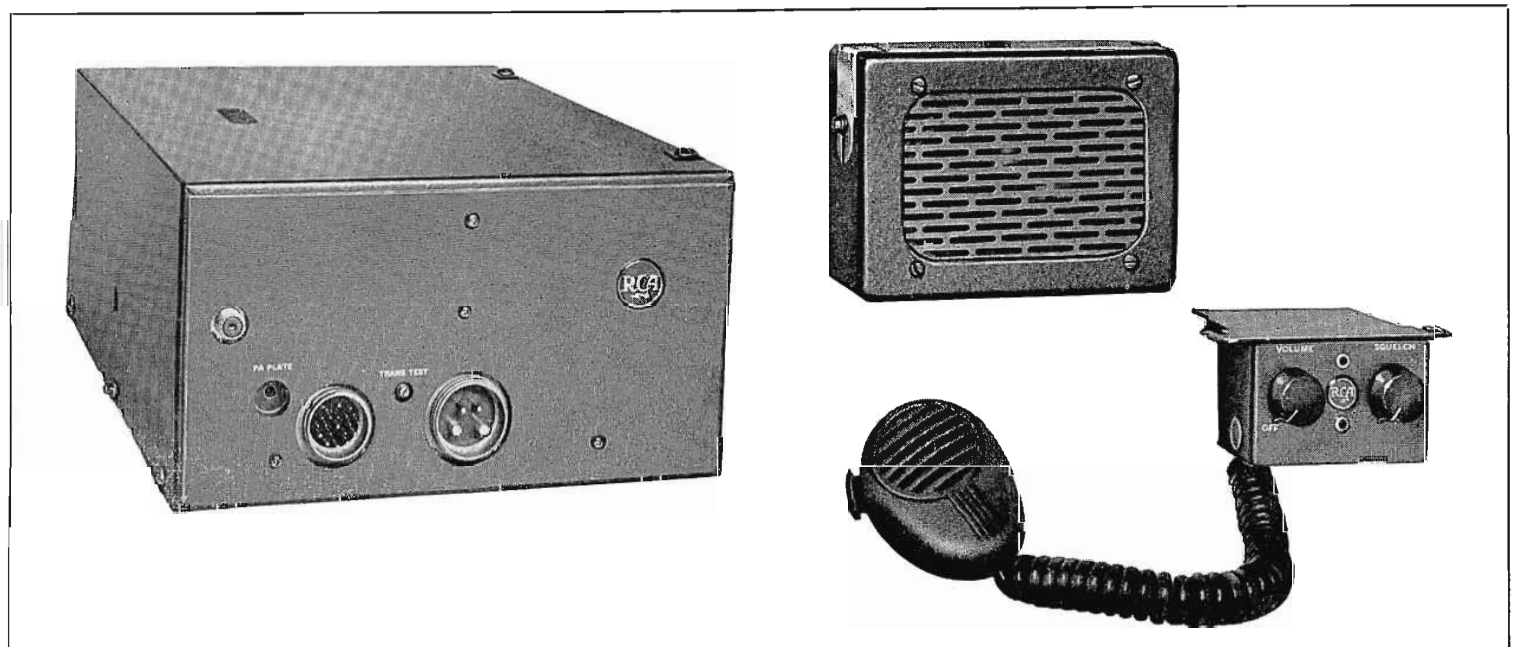
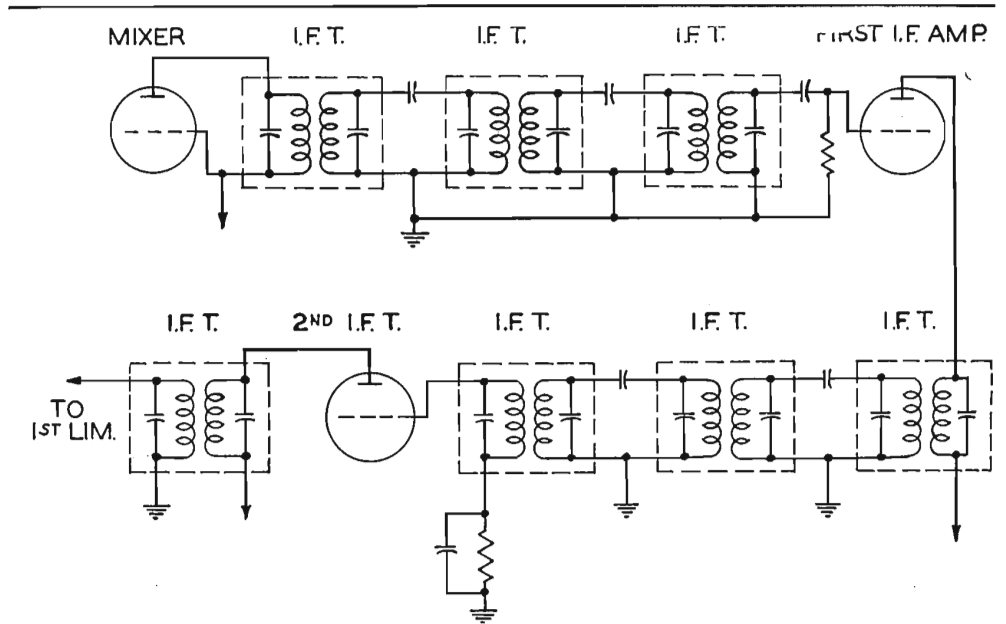

FIG. 7. In the third test of four-channel operation, operators could easily call in from distances of five miles with no interference.



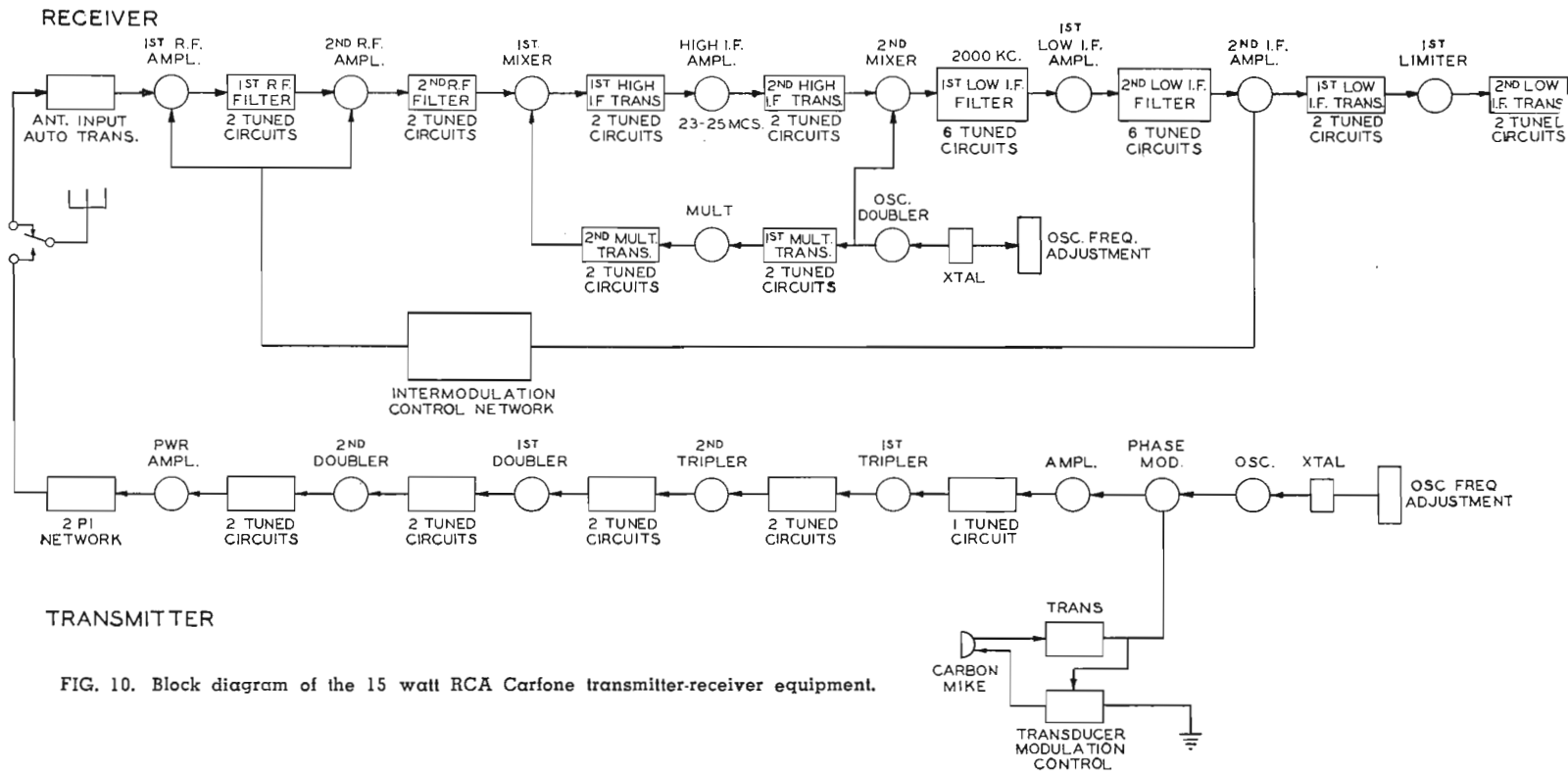

FIG. 10. Block diagram of the 15 watt RCA Carfone transmitter-receiver equipment.

The two nearby mobile transmitters produced intermodulation products in the receivers tuned to the distant transmitters, as shown in the preceding section. However, the distant mobile transmitters, were able to call in from a distance of 5 miles with no interference, as shown in Fig. 7.

If the mobile units that were producing the interference were brought in nearer,

some intermodulation response would have been noted, but they could come very close before they would block out the transmitters which were 5 miles away. This represents a remarkable improvement over the older designs which have an interference area of about a mile and a half as compared to approximately 0.4-mile with the new Radio Corporation of America equipment.

When a 4-channel system is put into operating using this equipment, interference-free reception could be expected in all cases except where two interfering channels are within 0.4-mile of the receiving antenna. For practical operating conditions, the number of times that two interfering transmitters will be operating simultaneously within 0.4-mile from the receiver will be small enough to provide very satisfactory performance.

The object of these field tests was to determine the parameters necessary to produce a new product economically while assuring adequate performance. The following decisions were made in order to provide adjacent channel operation in a low cost mobile system:

Mobile Receiver

1. Sensitivity—0.5 microvolt for 20-decibel quieting.
2. Adjacent channel selectivity—100-decibel attenuation at ± 60 kc.
3. All spurious responses to the attenuated 85 decibels.
4. Frequency stability—0.003 per cent from -30 to $+60$ degrees centigrade, ambient.
5. Frequency range—152 to 174 mc.

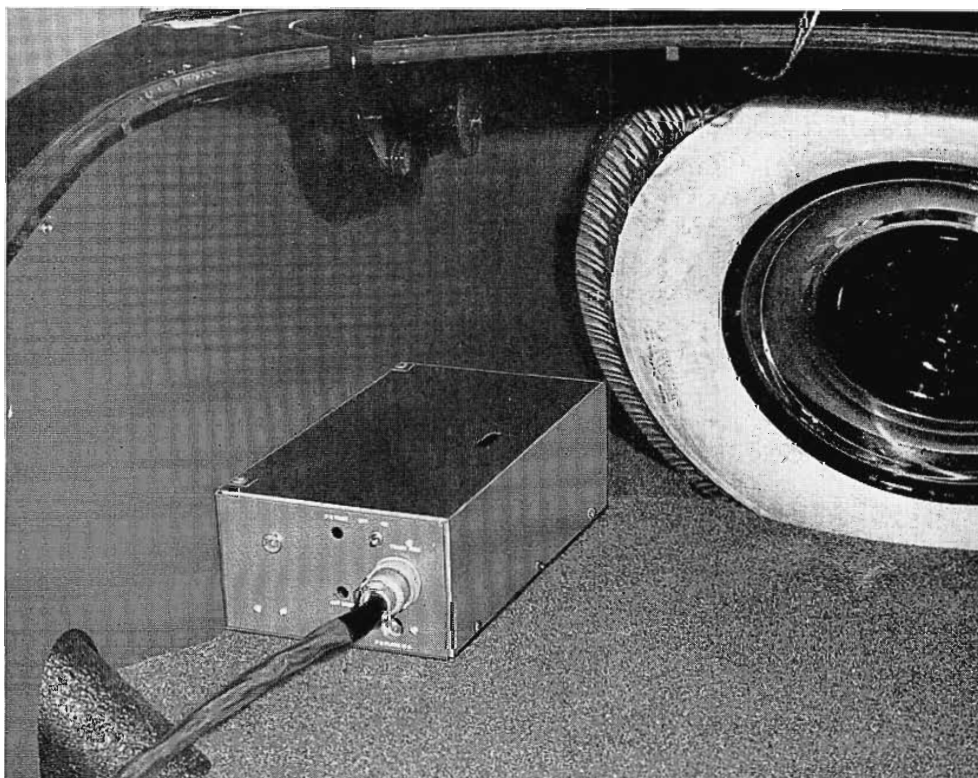

FIG. 12. RCA two way radio communications equipment takes up very little space in car trunk. It mounts in space behind the spare tire, as shown, and is very easily available for servicing.

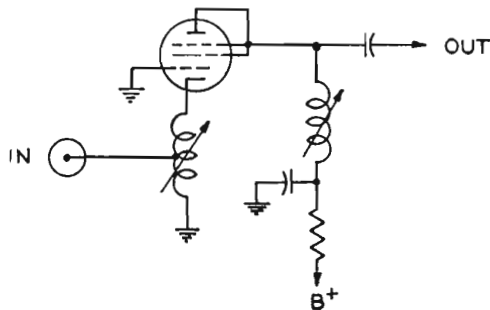
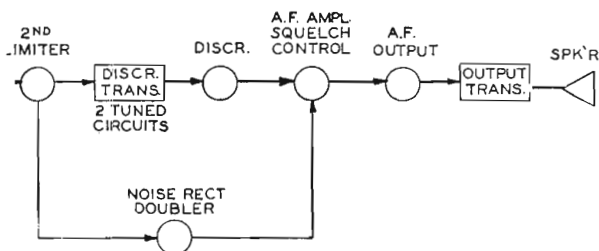

FIG. 11. Radio frequency amplifier in the first stage of the receiver.

Mobile Transmitter

1. Power output of 12 to 14 watts.
2. Modulation limiter which produces a high average modulation on sudden increase of speech energy. The limiter should prevent overmodulation and introduce no distortion or microphonics.
3. All spurious emissions to be attenuated at least 60 decibels.
4. Frequency stability—0.003 per cent from -30 to +60 degrees centigrade, ambient.
5. Frequency range—152 to 174 megacycles.

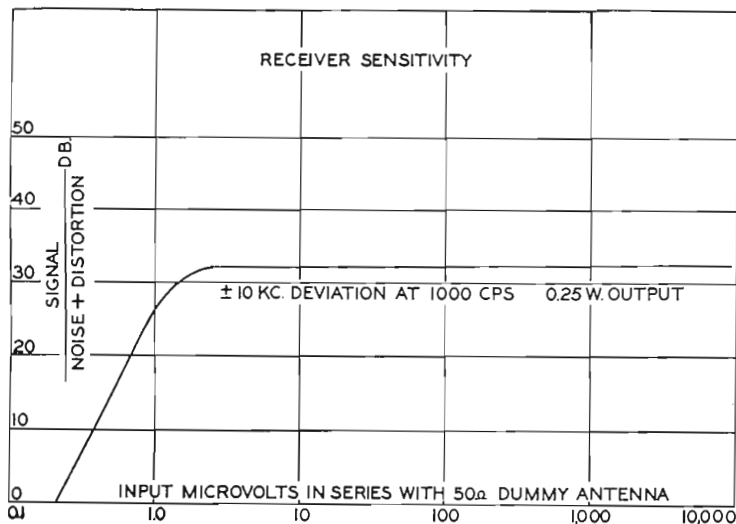

FIG. 14. Receiver sensitivity.

The land station equipment must necessarily equal or better the performance of the mobile receiver and transmitter as outlined before.

RECEIVER DESIGN

General Requirements

It was determined that sufficient intermediate frequency selectivity and over-all system stability could be achieved without too much difficulty for adjacent channel operation in the same locality if a peak transmitter frequency deviation of ± 15 kc and a maximum audio-modulating frequency of 3,500 c.p.s. was maintained.

Measurements and tests indicated that the receiver should have a sensitivity in the order of 0.5 microvolt input for 20 decibels of noise quieting, because the ambient noise level was found to be low enough in a number of areas where the equipment may be used to provide reliable communication on a 0.5 μ v signal if the receiver had the required sensitivity.

As far as the intermodulation problem is concerned, it was reasoned that intermodulation should be very little more severe with adjacent channel operation than with alternate channel operation. Little radio-frequency selectivity can be achieved with components that will fit into a mobile receiver at either 60 or 120 kc off resonance. Anything that could be done to improve the receiver's susceptibility to intermodulation interference and desensitization by improvements in circuit design, aside from increased radio-frequency selectivity, should therefore be equally effective for adjacent or alternate channel operation. From results of these early calculations and tests, a receiver was

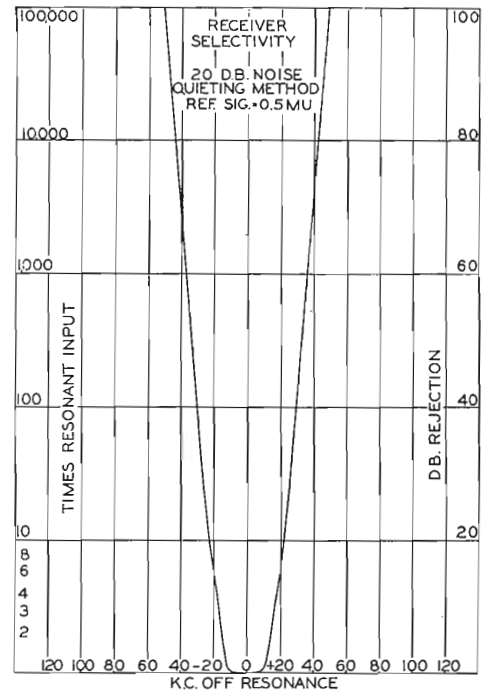

FIG. 13. Receiver selectivity.

designed incorporating the features believed necessary to make adjacent channel operation in the same locality possible

Circuits Required

One hundred decibels of selectivity was provided at 45-55 kc off resonance. This selectivity was obtained with more or less conventional intermediate frequency transformers, except that three transformers were coupled together between the mixer and first intermediate frequency amplifier stages, and three more transformers were coupled together between the first and second intermediate frequency amplifier stages, see Fig. 8. The over-all receiver is designed so that most of its gain occurs after the major portion of its selectivity, thereby permitting the receiver to receive

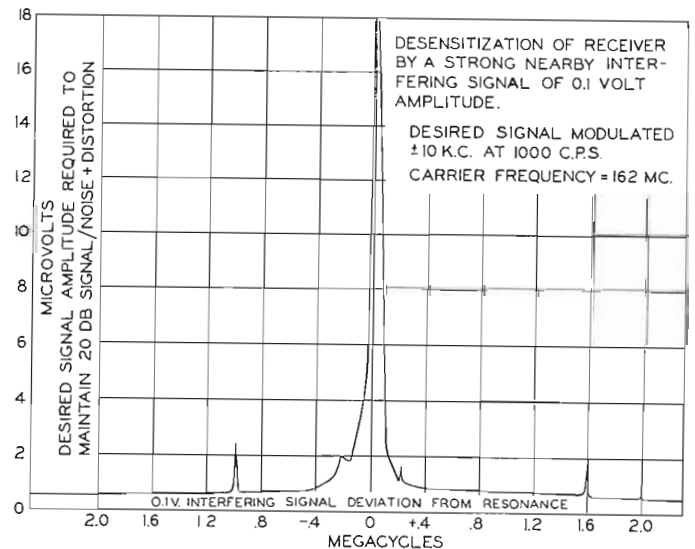

FIG. 15. Receiver spurious response rejection.

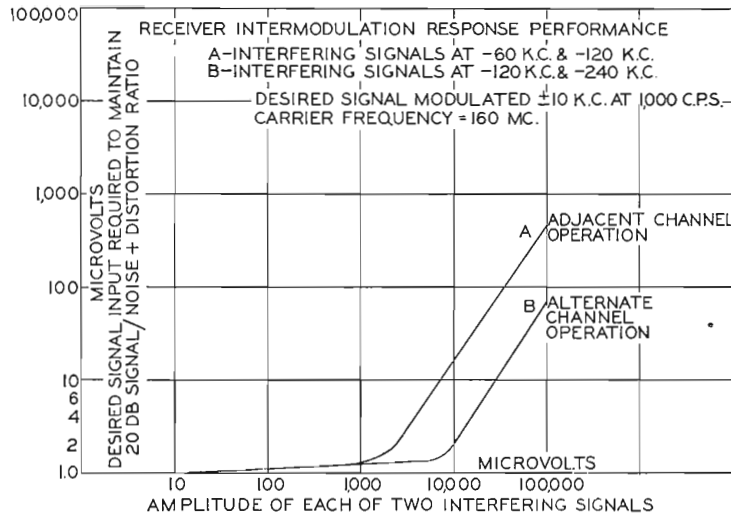

FIG. 16. Receiver intermodulation rejection.

a very weak desired signal with a strong undesired signal present.

The sensitivity requirement was met by using a type 6BH6 pentode tube, triode connected in a grounded-grid radio-frequency amplifier circuit, see Fig. 11. This circuit provided approximately the same amount of sensitivity that could be obtained with a type 6AK5 in a conventional radio-frequency amplifier circuit at a greatly reduced tube cost, and with the same tube type used extensively throughout the remainder of the equipment.

Automatic volume control bias from a limiter stage is applied to the grids of the radio-frequency amplifier tubes. This, along with some refinements in the radio-frequency amplifier and first mixer design, considerably improve the intermodulation rejection performance, because the desired signal will bias off the radio-frequency amplifier stages and reduce the amplitude of the undesired signals at the first mixer grid. Since the selectivity to the automatic volume control takeoff point is in the order of 100 decibels, the undesired signal can never produce a control voltage.

Performance of the Receiver

The series of curves illustrated in Figs. 13-18 show the performance of the new receiver. Fig. 13 shows the noise quieting

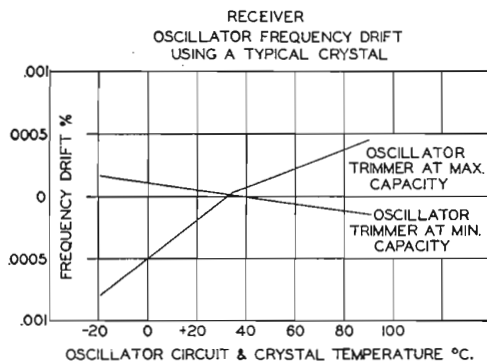

FIG. 18. Receiver oscillator stability.

selectivity of the receiver. The information for this curve was obtained by inserting sufficient radio-frequency signal input to the antenna at the receiver's resonant frequency to produce 20 decibels of noise quieting. The signal generator was then detuned above and below resonance to 60 kc, the adjacent channel in steps of 10 kc, and the signal generator output increased until 20 decibels of noise quieting was obtained.

Fig. 14 shows the receiver sensitivity in terms of signal-to-noise plus distortion ratio versus input microvolts in series with a 50-ohm dummy antenna. The input signal was modulated ± 10 kc at 1,000 c.p.s.

Fig. 15 shows how much the receiver is desensitized by a strong signal close to the receiver resonant frequency, and also the spurious responses of the receiver. To obtain this information two signal generators were coupled into the receiver antenna connector. The interfering signal amplitude was kept constant at 0.1-volt and its frequency was varied ± 10 megacycles from receiver resonance. The desired signal was modulated ± 10 kc at 1,000 cycles per second and its amplitude was adjusted to maintain a 20-decibel signal-to-noise plus distortion ratio.

Fig. 16 shows the performance of the receiver under conditions causing intermodulation. Curve A is for two signals, -60 kc and -120 kc off resonance, and curve B is for two signals, -120 kc and -250 kc off resonance. The amplitude of each of the two interfering signals was equal for each measurement, and the amplitude of the desired signal was adjusted for each measurement to produce a 20-decibel signal-to-noise plus distortion ratio. It will be noted that the receiver's susceptibility to intermodulation response averages only about 9 decibels more for ad-

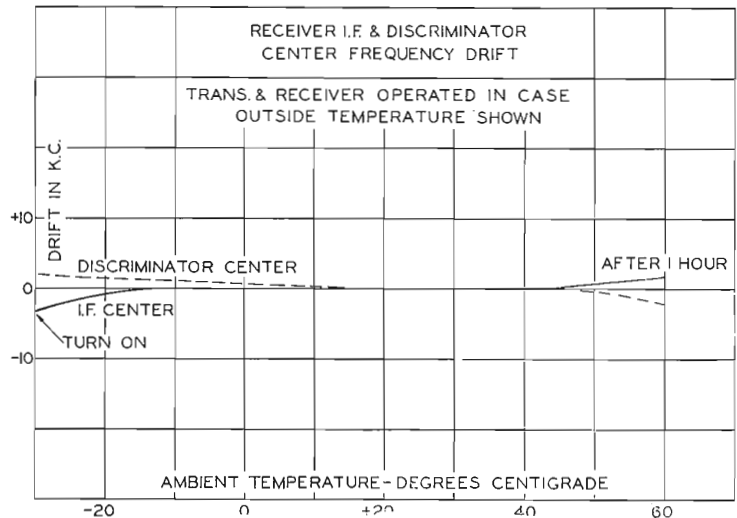

FIG. 17. Receiver intermediate-frequency drift.

acent channel systems than for alternate channel systems. This variation is largely due to the difference in the receiver's adjacent and alternate channel rejection plus the difference in receiver desensitization for the two cases.

Fig. 17 shows the intermediate frequency amplifier and discriminator center frequency drift over an ambient temperature range of -30 to +60 degrees centigrade. In making these tests the receiver was operated in its case along with the transmitter, and the transmitter was operated to produce the normal temperature rise inside the equipment case.

Fig. 18 shows the complete oscillator circuit frequency drift with a typical crystal and with the oscillator frequency trimmer capacitor set at both maximum and minimum capacity.

TRANSMITTER DESIGN

Spurious Emissions

The problem of reducing spurious emissions from the transmitter was attacked by using a low crystal multiplication, by using double-tuned circuits in all multipliers and using a maximum per stage multiplication of three, by filtering all B+ leads and by using a 2-section band-pass filter for matching the power amplifier to the antenna.

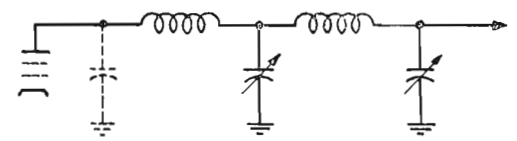

FIG. 19. Transmitter output circuit.

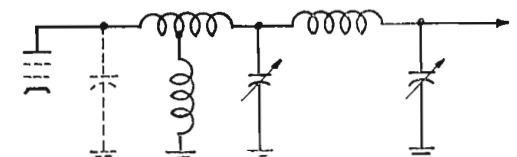

FIG. 20. Transmitter output filter circuit.

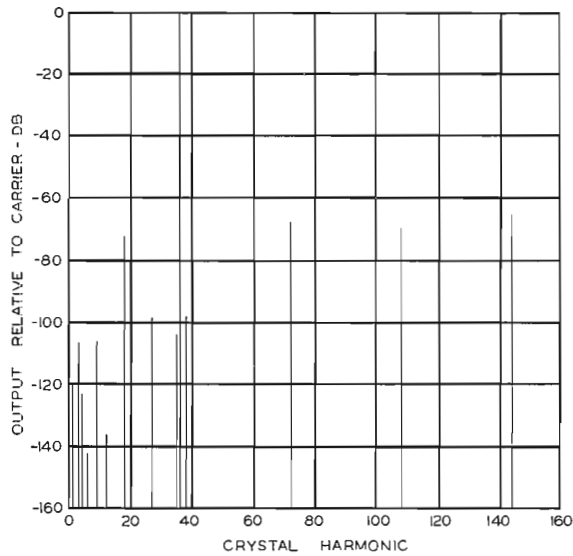

FIG. 21. Chart of spurious emissions of RCA Carfone transmitter, type CMV-1A, tuned to 158.31 mc.

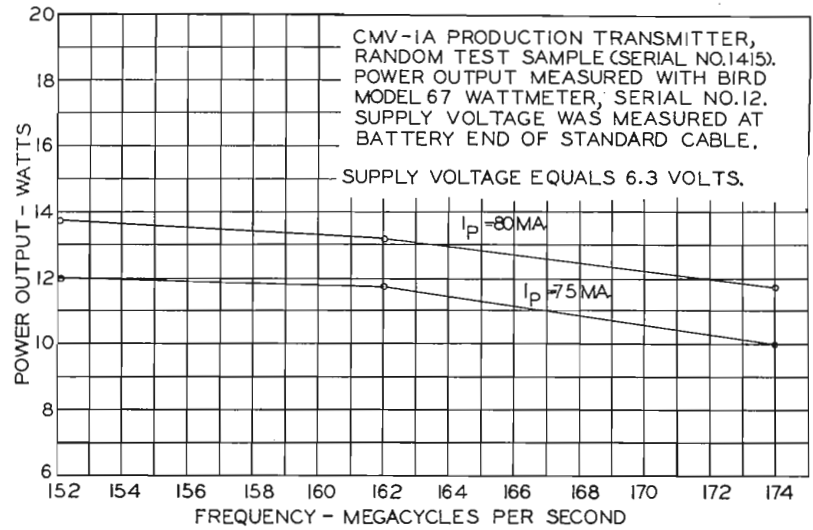

FIG. 22. Power output chart of transmitter random test sample.

A transmitter using phase modulation normally employs considerable frequency multiplication in order to achieve ± 15 -kc carrier frequency deviation at low-audio frequencies. The phase modulator used in this apparatus is capable of approximately ± 90 degrees shift so that a multiplication of only 36 is required to allow full deviation for a 300-cycle modulating frequency. This multiplication is arrived at by use of two triplers and two doublers.

All multiplier stages were double tuned in order to obtain the selectivity required. Double tuning also is quite helpful in reduction of difficulty caused by ground currents, since magnetic coupling allows circuit isolation except for stray capacity coupling.

All $B+$ leads were filtered by resistance-capacitance combinations in order to re-

duce coupling from this source. Resistors are actually better than chokes for this service since they do not have resonant transmission points and therefore filter over an extremely wide band. An additional advantage of this method of isolation is that trouble shooting is considerably simpler in the case of $B+$ short circuits, since the resistors will either burn up and act as a visible blown fuse or will provide isolation so that an ohmmeter can be used to detect the bad circuit.

In the initial design work of the power amplifier output circuits, we had planned to use a simple 2-section network of the low-pass type as shown in Figs. 10 and 19. While this operated as predicted to reduce carrier harmonics, it allowed transmission of a one-half carrier frequency component which would normally have been elim-

inated by a parallel resonant circuit in the plate of the power amplifier; a parallel resonant circuit does not, of course, eliminate carrier harmonics to anything like the extent of the low pass π circuit under consideration. This one-half carrier frequency component was getting through the doubler plate and power amplifier grid circuits with sufficient amplitude to be amplified by the power amplifier and cause trouble. Accordingly the first π circuit was changed to a band-pass network by the addition of a shunt coil tapped on the first series inductance, as shown in Fig. 20.

Care was taken in circuit layout, shielding, and grounding in order to prevent coupling around the circuits provided. Particular attention was paid to the antenna changeover relay, which is of a type proved by many years of successful aircraft serv-

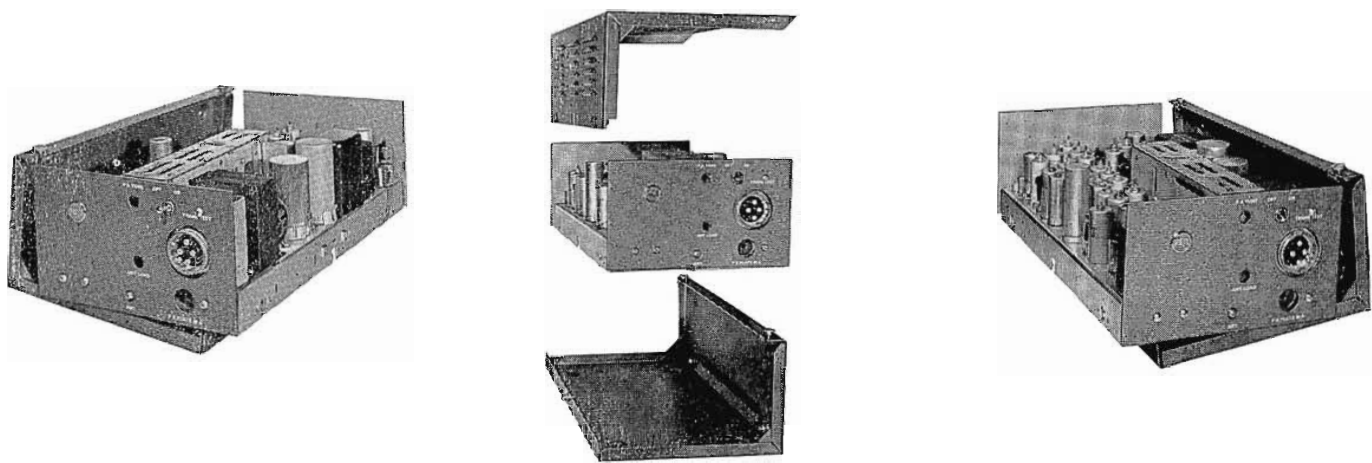
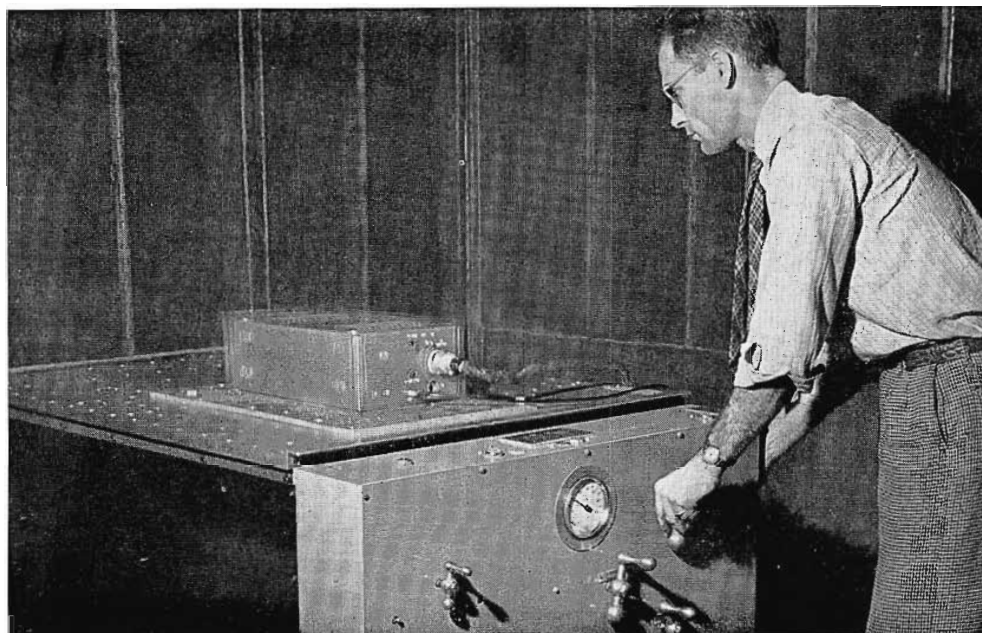
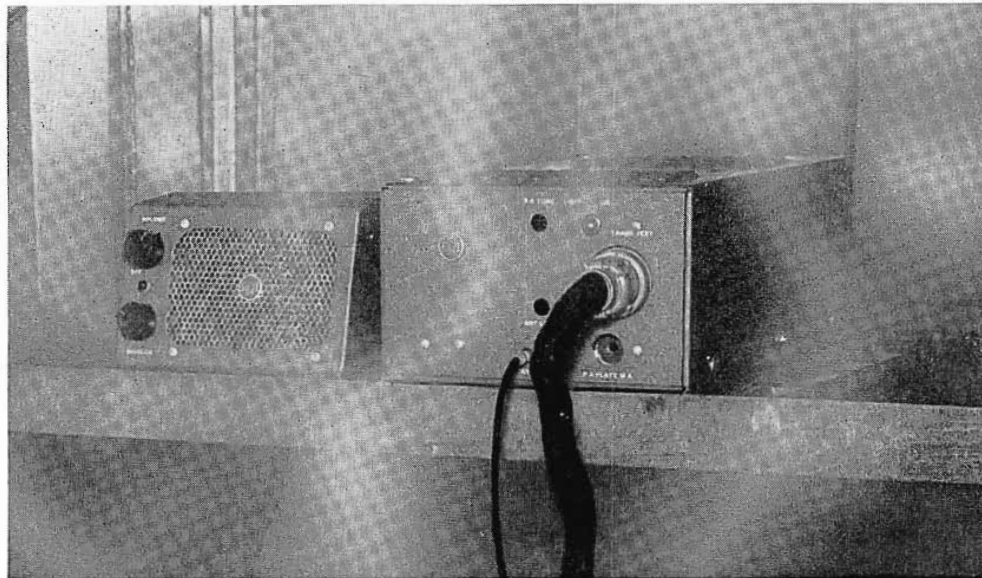
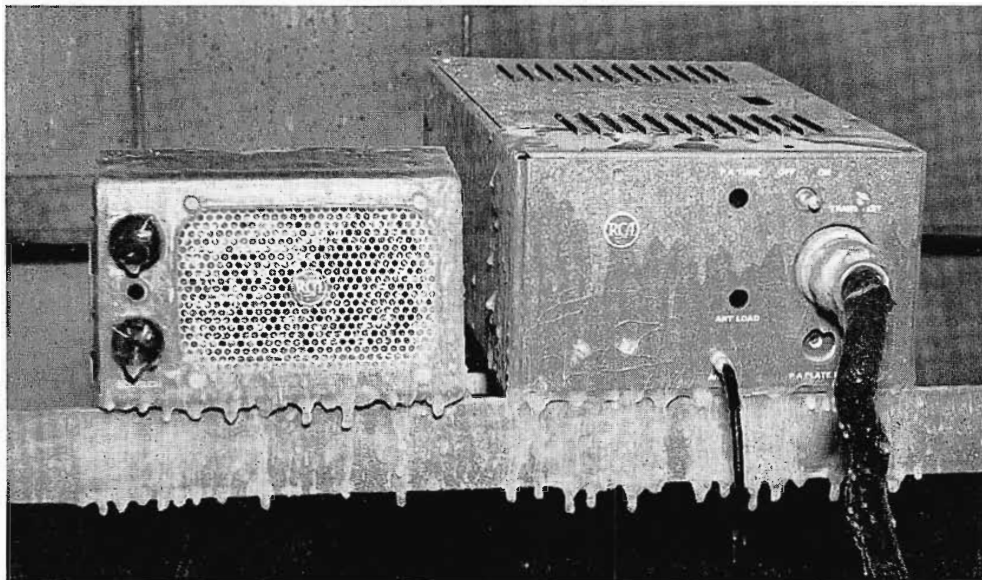

FIG. 23. The ingenious construction of the Carfone permits the widest choice of installation locations. The mounting base of the mobile equipment becomes one-half of the case. The cover becomes the top of the case forming "sandwich case" construction and providing such great flexibility as reversing the chassis 180 degrees without changing the position of the case plate or cover. This type of construction simplifies servicing, and requires no headroom as in drawer type cases. As shown at left, the chassis is ready for left-hand mounting; and for right-hand mounting at extreme right. Accordion view, in center, shows the construction of the chassis and housing.

RCA CARFONE PASSED "Torture Chamber" TEST WITH FLYING COLORS



ice to give less trouble than has been encountered with available coaxial types. The relay is carefully shielded, yet the contacts are readily accessible for service.

The engineering model showed no spurious emission in excess of 70 decibels below carrier frequency, as shown in Fig. 21. Measurements were carried from 4.2 megacycles (the crystal frequency) to about 800 megacycles. Production models which have been tested have shown variations of about ± 6 decibels from the values given in Fig. 22.

Power Output

The total power amplifier plate network efficiency is slightly better than that which is obtained by use of a more conventional parallel tuned circuit, thus allowing a power amplifier efficiency of approximately 50 per cent. This efficiency is quite good for a 2E26 tube with only a 310-volt plate supply at 152-174 mc. Power output versus frequency is shown in Fig. 22.

Power Supply

Two power supplies are used for the transmitter. A small power supply is used for either the receiver or for the transmitter low level and audio circuits. A larger supply is used for the doubler-driver and power amplifier stages only.

The small power supply utilizes a self-rectifying vibrator and delivers 50 milliamperes at 200 volts. This supply runs continuously when the equipment is turned on and is switched from receiver to transmitter by contacts on the antenna relay.

The larger power supply delivers 135 milliamperes at 325 volts, using an interrupter-type vibrator and a separate full-wave rectifier. The vibrator has two sets of interrupter contacts which are wired separately to individual primary windings on the power transformer to obtain good contact life. The rectifier is either a single OZ4-A or two 6X5GT tubes connected in parallel. The two 6X5GT tubes may be used in applications where maximum reliability is required on much-used systems. The OZ4-A is recommended for normal

FIG. 24. To insure optimum performance under extreme conditions of temperature, humidity, and vibration, RCA engineers subjected the Carfone equipment to much tougher treatment than it has to take in actual practice. The Carfone passed tests illustrated (left). ICE TEST: -30 to $+60$ degrees; HUMIDITY TEST: 90 percent humidity at $+60$ degrees C. for several days; VIBRATION TEST: several hours of constant vibration in three planes with amplitude of $\pm 1/32$ inch at a frequency variation of 5 to 55 cycles per second.

use where battery drain is important and usage is not too frequent. The OZ4-A is a cold cathode-gas rectifier and its life is approximately 15,000 to 45,000 starts.

Transmitter Tests

Spurious emissions were tested on the antenna line by a substitution method. Each crystal harmonic was measured on a receiver. A calibrated signal generator was then adjusted until the receiver signal strength readings were the same. The ratio of the generator output to the line voltage existing at the carrier frequency was taken as the ratio of spurious signal to desired carrier. It was necessary to trap out a portion of the fundamental carrier frequency to prevent its reaching the receiver; it was found that the receivers used would produce harmonics of their own if fed a very strong signal.

Actual field intensity measurements also were made with equipment installed in an automobile. In this case, field intensities were obtained for the carrier and the various crystal harmonics, and were compared directly. The automobile itself was rotated for maximum pickup and both the horizontal and vertical components of radiation were obtained.

Limiting action was checked by use of an oscillograph connected across the discriminator of a suitable receiver and calibrated for deviation. Normal voice inputs were used with widely varying inflections and levels. Both male and female voices were tried. It was found possible to over-modulate the equipment for the first portion of certain syllables if spoken very loudly after a prolonged quiet period; however, as expected, quality was very good throughout the range of inputs used. To check the seriousness of the occasional short burst which could get through, systems were operated on adjacent channels (60 kc separation) and it was found that while an occasional burst could be heard when the interfering signal was very loud and close to the receiver, it was of such short duration that no intelligence was lost.

SYSTEM DESIGN CONSIDERATIONS

Exact Frequency Adjustment

Simplicity in adjusting the mobile receiver to the land station transmitter was accomplished by providing a vernier capacity in the crystal oscillator circuit to give a frequency adjusting range of ± 0.01 per cent. This vernier capacity is adjusted to give zero discriminator voltage when receiving the desired signal. It is not neces-

sary to change the adjustment of the discriminator or intermediate frequency amplifier circuit. The mobile transmitter crystal-controlled oscillator circuit also is provided with a vernier capacitor which is adjusted to give zero discriminator voltage at the land station receiver.

Temperature, Humidity, and Vibration

To insure optimum performance under extreme temperature variations from -30 to $+60$ degrees centigrade ambient temperature, the completed equipment was carefully tested and measured as shown by Figs. 17 and 18. The equipment was tested for several days at 90 per cent humidity and 60 degrees centigrade, as shown by Fig. 24. The mobile equipment was designed to operate at optimum per-

formance while subjected to several hours of vibration in three planes with an amplitude of $\pm 1/32$ inch and a frequency variation from 5 to 55 c.p.s. See Fig. 24.

Mounting and Servicing

The mounting base of the mobile equipment becomes one-half of the case. The cover becomes the top of the case, see Fig. 23. The chassis is reversible 180 degrees without changing the position of the base plate or of the cover. Also, the equipment can be mounted in two planes. The chassis is removed from the case without requiring any headroom as in a drawer-type case. One main battery cable connects the equipment to the battery and to the control unit on the front dash board.

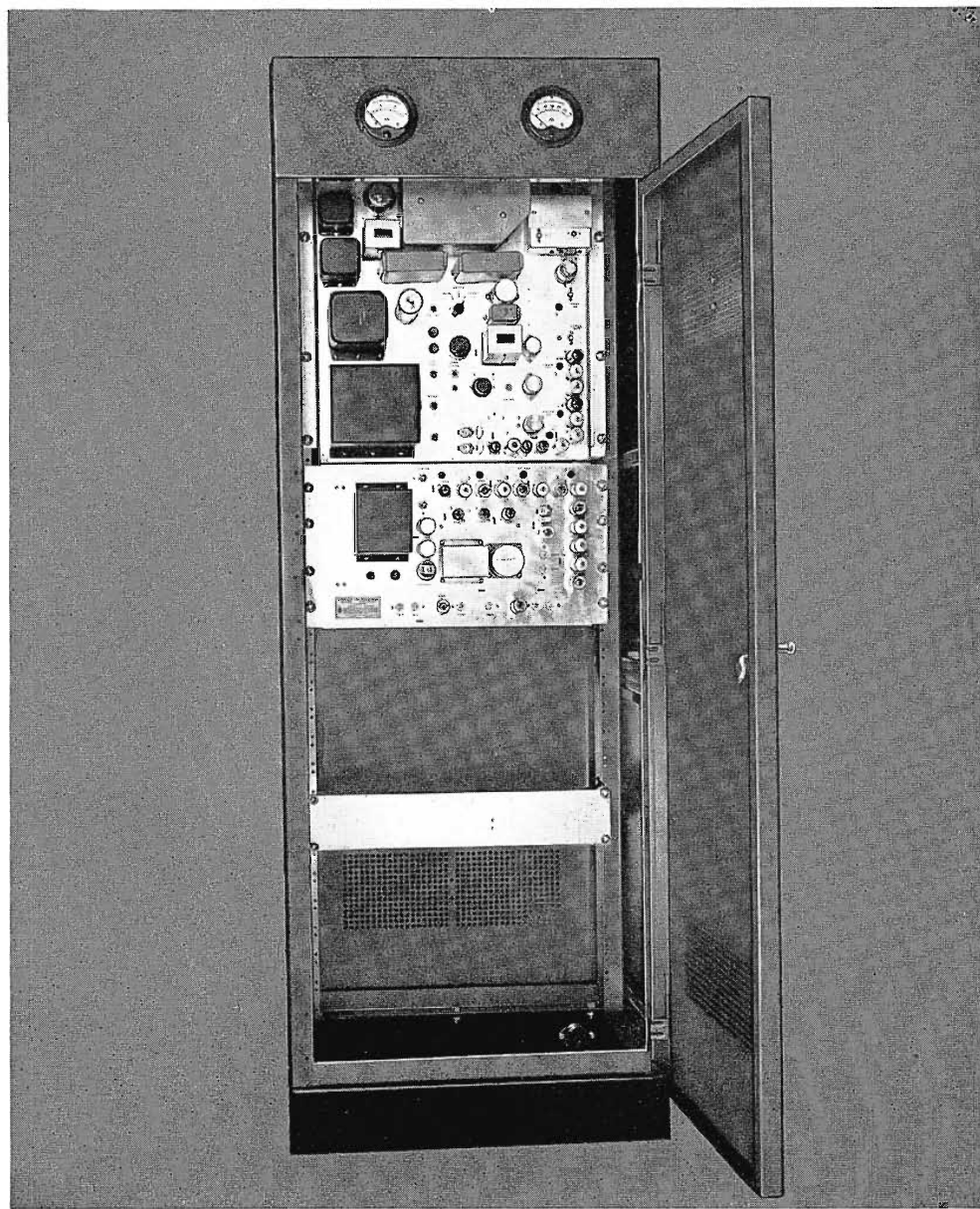

FIG. 25. RCA's two way radio systems are built to the same exacting standards as its broadcasting and television equipment. Shown above is a 70 watt station transmitter and receiver with separate built-in power supplies. Cabinet can accommodate additional receiver for dual frequency operation.

A FLEXIBLE TV AUDIO SYSTEM

In a previous article (see "Combining TV Transmitter Control and Program Switching," BROADCAST NEWS, No. 59) a simple audio-video switching unit was described. Also, it was shown how this equipment, RCA Type TTC-3A1, would permit a television system to be placed on the air with a very minimum outlay of equipment. In this setup, only film facilities, slides and network programs were accommodated.

The Single Studio System

Consideration shall now be given to the audio equipment requirements for a television system having a single studio, an announce booth, and facilities for handling film and remote or network program service. The lineup of audio equipment required for such an installation does not vary greatly from that of a comparably sized AM or FM installation; the main

By W. L. LYNDON
Television Terminal Engineering

differences being the additional facilities necessary for handling the audio output of the film projectors and a communication system to be used by the program director for coordinating the program sequences.

This audio system is based on the use of standard stock speech input units and consists of three main items:

1. One 76B5 Console.
2. One BCS-3A Control Unit.
3. One Rack of Speech Input Equipment.

This arrangement is capable of switching, mixing, and monitoring the following program sources:

1. Studio.
2. Announce Booth.
3. Film.
4. Transcription.
5. Network and Remotes.

Loudspeaker monitoring facilities are provided in the main control room, studio, announce booth, and projection room. The speaker in the studio serves as both a cue and talkback speaker. The studio speaker is also tied in on an over-ride circuit which will permit transcriptions or sound effect records to be heard in the studio during "on-the-air" operation.

In order to simplify the description of this system, reference should be made to Fig. 1, a single line block diagram of the 76B5 console which is employed as the system's basic unit.

FIG. 1 (below). Simplified block diagram of 76-B5 Console.

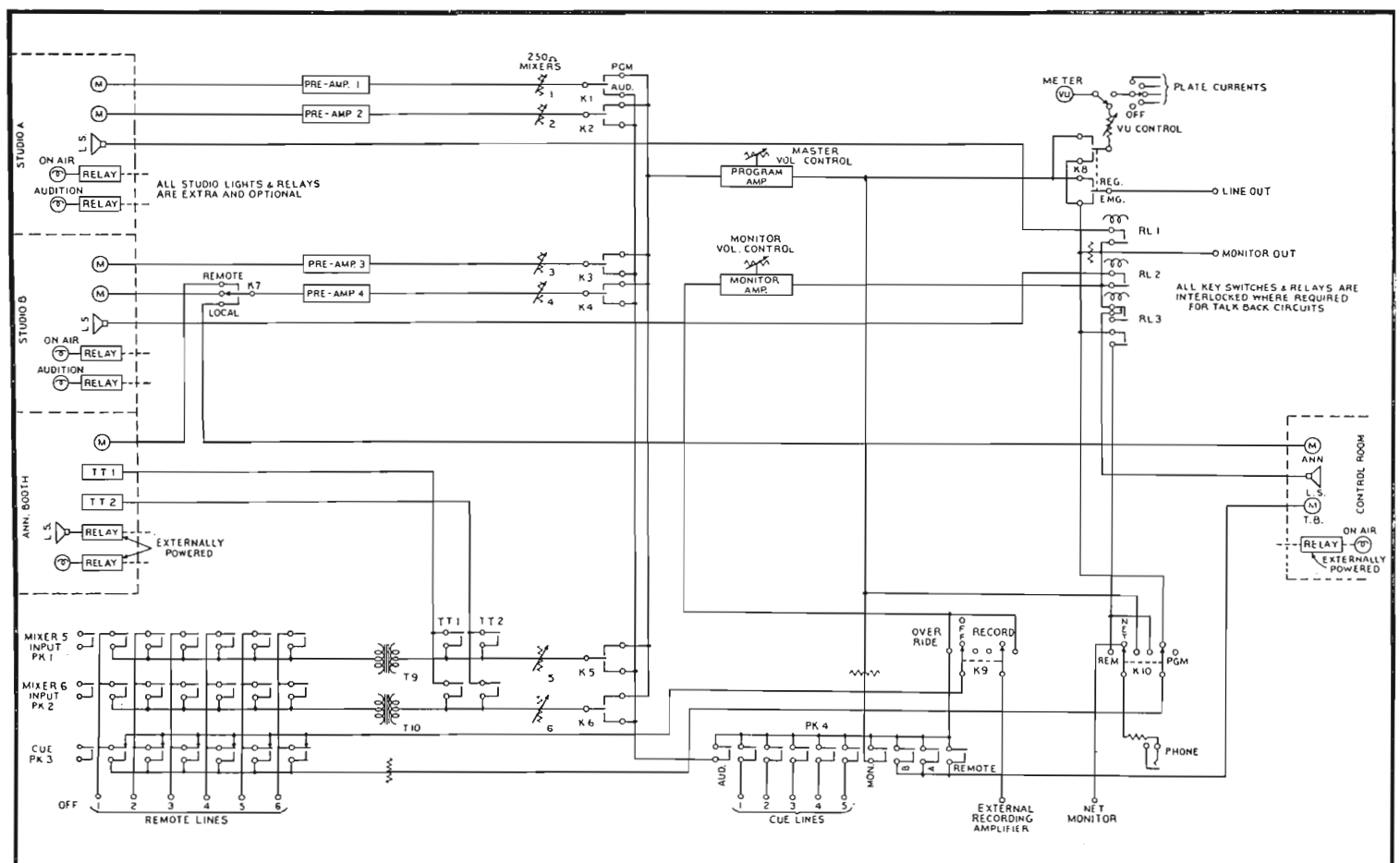



FIG. 2 (above). The RCA 76-B5 Consolelette serves as an important part of the TV audio system. It incorporates four pre-amplifiers feeding a six-position mixer system.

It will be noted that the consolette (Fig. 1) has four pre-amplifiers feeding into a six-position mixer system. Two of the mixers are connected through isolation line coils to six position mechanically interlocked line switches. The program level from the remote lines, after equalization and the two turntable positions, is controlled by these two mixers. Each of the six mixers feeds into a lever key which will permit placing the circuit to either a program or an audition bus. This feature permits circuits to be monitored before being switched to the program bus. These lever switches associated with the mixers are tied in with the studio cue and talkback circuit. When they are in the program position the talkback or cue circuit cannot be operated. In the normal "off" position, program is automatically fed into the studio. In the

audition position the talkback circuit between the control room and the studio can be operated. The program bus contains a program amplifier equipped with an inter-stage master gain control and has a normal output rating of plus 18 dbm with .5% distortion from 50 to 7500 cycles and a maximum output level of plus 26 dbm with 1% RMS distortion over the same frequency range. Across the output of this amplifier is located a standard VU meter with an adjustable input control. This meter is also capable of reading the indicated plate current of each amplifier tube located in the program channel.

The monitoring amplifier located in the audition channel is provided with considerably higher gain and higher power output in order that it might be used in con-

junction with a talkback circuit and also provide sufficient volume for the speaker system. There are three speaker control relays located within the consolette, and in this TV system they are used in conjunction with the control room speaker, studio speaker, and headphone monitoring for the microphone boom operator. The additional relays required for the projection room and announce booth are mounted on the rack equipment along with the "audition" and "on-air" studio signal control relays.

The input to the monitoring amplifier is terminated in a row of mechanically interlocked push type switches which select the circuit to be fed to the input of the amplifier. This includes the audition position, talkback circuit, and five "cue" line inputs. Two of these "cue" positions are

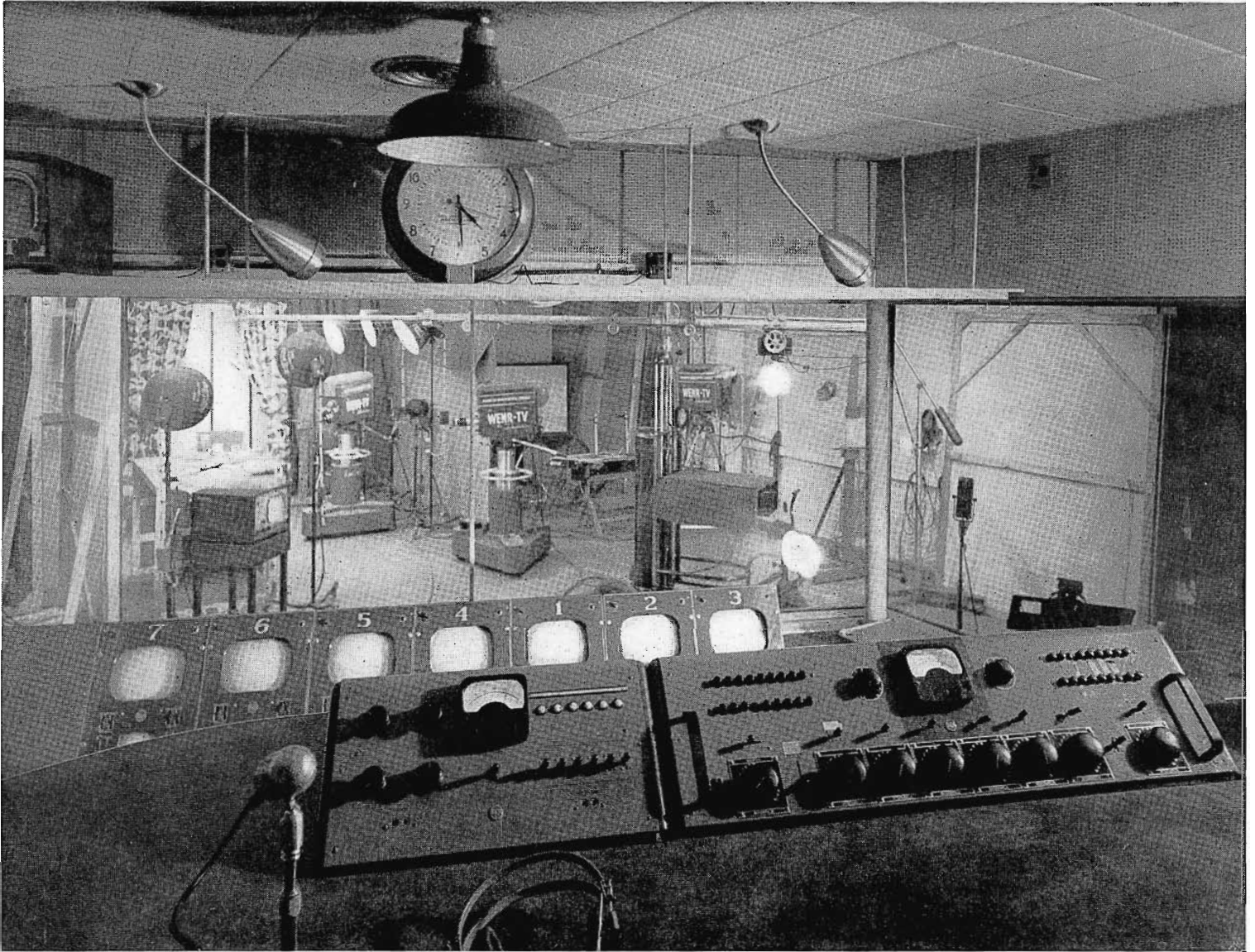

FIG. 3 (above). A typical station installation (photo by courtesy of WENR-TV) employing the audio system shown in Fig. 4. The audio units are located on a higher level, in order that the audio operator has visible access to the studio and video monitors.

used in this television audio system to monitor the output of the two equalized remote line circuits.

The power supply for this console is a self-contained unit housed in an electrically interlocked and ventilated mounted type cabinet with the rectifier chassis so constructed that it may be readily hinged out for servicing. This unit is normally mounted at a point remote from the console and interconnections made by suitable shielded leads.

Fig. 4 is a single line block diagram indicating how the console and the external units are combined to make up this television audio system. The studio is shown as having a total of eight microphone circuits, four of which are normal

through jacks on the speech input rack to the console preamplifier inputs. The remaining four positions are terminated on jacks to be patched into the circuits as required.

The quantity and types of microphones to be used are generally determined by the type of programming that is contemplated. Simple productions usually involve simpler microphone technique and many presentations can be handled very effectively with one microphone placed on a movable boom stand with possibly one additional floor stand, mounted or desk type microphone for commentary or announcement purposes. Productions of a more complex nature, such as dramatic presentations where more than one set is involved, present a greater problem, and to do the job effec-

tively and have the microphone in the right place at the correct time requires the use of a quiet operating, highly flexible boom stand having a large range of extension with a wide vertical and lateral swing. There are two types of microphone boom stands in general use today for television service; one of a semi-adjustable type which can have its extension and elevation adjusted beforehand and then wheeled into position. This type of stand can be used quite effectively on such productions that will permit the microphone to be placed above the scene being televised and not requiring any extensive movement of the microphone during the show.

Shows of a variety or dramatic type where there is considerable movement of

the artists, require a boom stand that will literally permit the microphone to follow them around the set. This type of stand is in general use in the motion picture industry, and one model recommended for TV programming is the MI-26574 (see Figs. 7 and 8). This particular stand provides an operating station for the boom operator and the whole structure is mounted on rubber tired wheels which permit it to be readily moved across the floor. The length of the boom can be extended from 7 feet to 17 feet and the microphone can be "gunned" through an angle of 280 degrees. This boom stand, in the hands of a trained operator, can do much to offset the disadvantages of picking up sound at a greater distance from the source than is

encountered in the regular AM or FM system of broadcasting. In selecting this latter type of stand, consideration should be given to the size of studio in which it is to be operated. In small stations where staging space is at a minimum, it would be more practical and more economical to use the semi-adjustable type KS-4A Magic Lock boom stand.

Microphones that are used for broadcast service can also be employed for television programming. Such types as the 44BX, KB-2C, 88A, and 77D are in general use. The 44BX is a bi-directional ribbon type used for orchestra or band setups and certain commentary programs where its appearance in the picture is not a center

point of distraction. Due to its bi-directional characteristic and its mechanical construction, it is not generally recommended for boom operation where there is likely to be extensive movement of the boom during the show.

The KB-2C is a bi-directional ribbon microphone having essentially the same sensitivity as the 44BX but much smaller in size and weight. Its size makes it particularly popular for use as a concealed microphone. It has been extensively used for round table discussions, piano pickup, soloist and as concealed microphone for dramatic presentations. Due to its similarity to the 44BX, it is also not generally recommended for movable boom stand service.

FIG. 4 (below). Single line block diagram of a flexible TV audio system for one studio, announce booth, remote lines and film projection room.

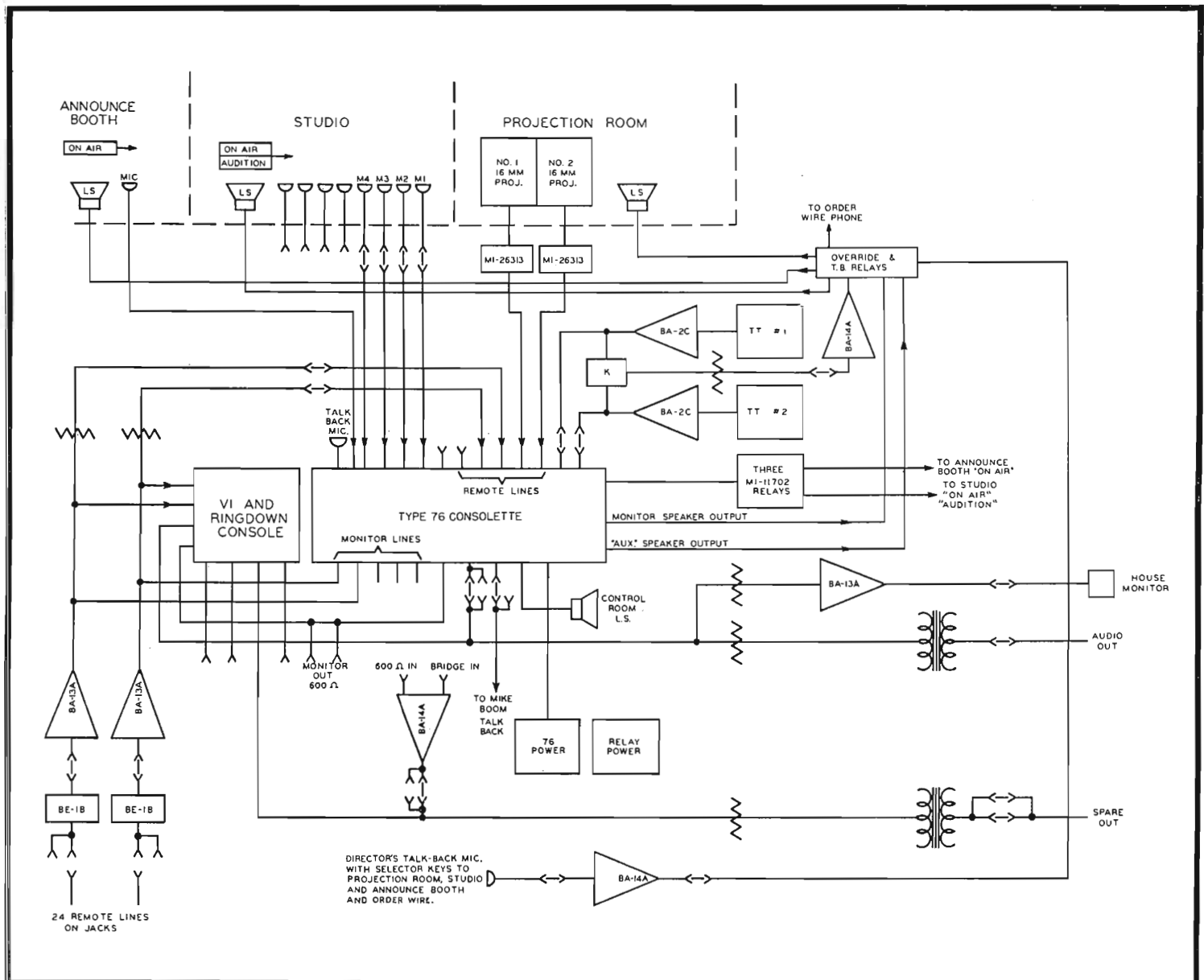

The 88A is a unidirectional pressure operated type of microphone and its small size permits it to be used at many of the pickup points recommended for the KB-2C. Its unidirectional characteristic may prove to be advantageous over the KB-2C in some instances, especially where a high background noise is encountered. It is particularly recommended for outside or field use.

The microphone generally recommended for boom service is the type 77D. This is basically a ribbon microphone operating on a velocity-pressure principle. It has three directional characteristics, namely: uni-directional, bi-directional, and non-directional. For boom service it is generally set in the uni-directional position, which will permit artists to operate at a

greater distance from the microphone and its directive characteristic will favor reduction of reverberation and background noise level.

The studio monitor speaker serves three functions, namely:

1. Talkback.
2. Cue or Monitor.
3. Effects Speaker.

The latter circuit permits sound effects records or transcriptions to be fed into the studio for special effects purposes while it is "on-the-air".

Relays are included in the rack equipment that will permit the operation of an "on-air" studio signal and "audition" lights.

The equipment required for the announce booth consists of an announce microphone, a monitor loud speaker, and "on-air" signal light. Any of the previously mentioned microphones may be used for this service. When the studio is "off-the-air", program is automatically fed into the announce booth. The operation of the "Announce" key on the consolette places the microphone in the circuit, opens the monitor speaker circuit, and turns on the "on-air" signal light.

The output of this announce microphone circuit may be fed directly through the consolette to the line, as an example, in supplying commentary for slides or silent motion pictures, or it may be mixed with the output of the sound from the studio, motion picture projectors, the remote line

FIG. 5 (below). This station also employs the audio system setup shown in Fig. 4, with a different arrangement of equipment. Note, 70-D Turntables, located at the left, audio TV control at center, program director's console and camera control units at right, form a single operating unit.



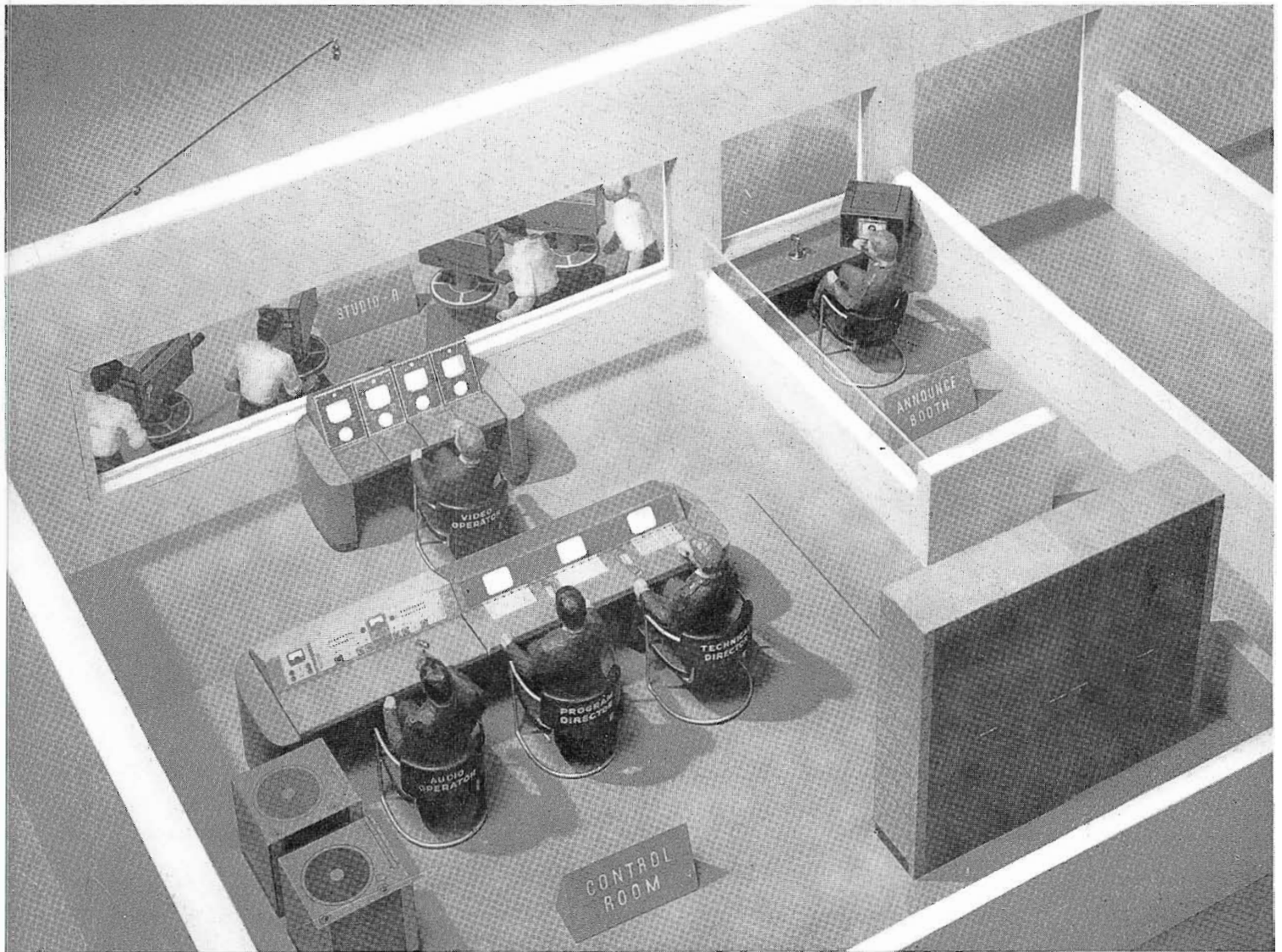

FIG. 6 (above). This arrangement of model TV units shows how the essential equipment items of Fig. 5 might be re-arranged to form a "two-level" setup to provide greater visibility for audio operator.

circuits, or, if necessary, may be mixed with the transcription outputs.

The audio equipment for the projection room is of minor nature. Stations of this size would normally use two type TP-16B 16mm projectors whose output level is plus 4 dbm. This should be attenuated to approximately -20 dbm before being fed into two of the remote line positions on the console. Due to the fact that considerable variation in frequency characteristics is liable to be encountered from the various types of films that may become available for television use, it is recommended that an MI-26313 equalizer be employed in the audio output of each projector. The equalizer has three base and three treble boost positions as well as three base and three treble attenuator positions, in addition to a flat response position. This

equalizer is a "T" network and should be isolated from the input of the console by means of a line coil in order to obtain correct performance from the equalizer.

The loudspeaker serves as a monitor speaker and is tied in with the program director's talkback system.

In order to provide facilities for handling network and remote program circuits, two type BE-1B line equalizers and two type BA-13A studio amplifiers are included as part of the rack equipment. The BE-1B line equalizers are capable of equalizing normal program line circuits up to and including 15 KC. The BA-13A studio amplifiers have sufficient gain to bring the equalized line levels up to such an output that they may be read on a standard VU meter. This permits the lines to be equalized and level adjusted before being placed on the

air. The outputs of the BA-13A amplifiers are fed through a fixed attenuator pad to two of the remote line positions on the console. The BA-13A outputs are also fed to two of the monitor inputs, thus permitting complete remote line checking before going on the air. There are a sufficient number of jacks located on the rack to permit the termination of a maximum of 24 remote line circuits.

Transcription service does not play as important a part in television broadcasting as required for AM or FM broadcasting, yet such facilities must be provided for producing background music, fill-in for slides and silent motion pictures as well as sound effects. This system employs two Type 70-D turntables. The output of each machine feeds into a type BA-2C pre-amplifier and then to the transcription in-



FIG. 7. A flexible and easily-operated boom stand is an invaluable piece of TV studio microphone pick-up equipment. In this photo (courtesy of WOR-TV) boom operators may be seen extending the microphone to a desirable pickup position.

puts of the consolette. Across the outputs of BA-2C amplifiers is located a two-way lever key switch which will permit the signal to be fed to the input of a BA-14A monitoring amplifier. This key switch also

operates a relay which will permit this signal to be fed to the studio loudspeaker. This feature makes it possible for records to be used for dance purposes, accompaniments, and sound effects. The transcription

service can also, at the same time, be fed through the consolette channel to the line.

The regular line output position of the consolette is normalled through jacks and an isolation transformer to the outgoing line. This line is also bridged by another BA-13A amplifier which normally acts as an isolation amplifier to feed a house monitoring bus. It may also be used as a spare amplifier when required. A spare BA-14A amplifier is provided with its 600 ohm and bridging input circuits terminated on jacks. Its output is also normalled through jacks and a line coil to provide a spare line output circuit.

A standard consolette alone very seldom satisfies the complete requirements of a broadcasting installation and a television system is no exception to the rule. In order to increase the flexibility of the system and provide additional features, a companion unit, BCS-3A, has been developed to mount adjacent to the consolette. It contains a standard VU meter with a calibrated input control and a ten-position selector switch. A number of circuits are normally connected to the input of this switch, such as the output of the two BA-13A line amplifiers, the output of the spare BA-14A amplifier, and the regular output of the consolette. Across this switch is located a jack which will permit the use of a pair of headphones. On this panel is mounted the key switch for controlling the output of the two transcription turn-



Field Engineering Service to Broadcasters...AM, FM, TV

RCA Service Company engineers are experienced in all the latest techniques and are equipped with the most modern specialized measuring equipment. The RCA Service Company has been working hand in hand with the nation's broadcasters for over 25 years.

OUR SERVICE TO BROADCASTERS...

- Installation supervision and measurements of transmitting, studio and accessory equipment . . . AM, FM or TV.
- Prompt help in emergencies. Technical advice, service, and assistance on special problems.
- Instruction and training of station operating personnel.
- Performance measurements and adjustments for station compliance with FCC regulations.

- Measurement and curves on FM and TV antennas and accessory equipment, including transmission lines, matching networks, diplexers.

(For service outside the U. S. A., consult your Authorized RCA Distributor)

For further information call or write Communications Service Section, RCA Service Company, Inc., Camden, N. J.



RCA Service Company, Inc.

A Subsidiary of the Radio Corporation of America
CAMDEN, NEW JERSEY

NOW—restore the original quality of your RCA microphones, transcription pick-ups and test and measuring equipment under the new Factory-Reconditioning Plan. For complete details, write: Return Apparatus Control, Building 8-2, Camden, N. J.

tables for the studio speaker over-ride circuit and a suitable volume control for the input of its associated BA-14A amplifier.

A spare 250/250 ohm volume control is mounted on the console, and its input and output circuits are terminated in line transformers whose 150/600 ohm inputs and outputs are terminated in jacks so that they may be patched into a circuit when so required. Located on the right side of the BCS-3A unit is a six-position ring-down circuit, consisting of six relays, six indicator lights, and six ring-talk lever key switches. A jack is provided for inserting a standard telephone unit. These six input circuits are also terminated on jacks on the rack which permits them to be patched into the incoming lines as required. The power for operating the calling signal lamps is obtained from the 12 volt DC relay power supply. The ringing current is not supplied as part of this equipment. This intercom circuit, placed adjacent to the console, permits the operator to communicate directly with remote points without having to leave the equipment during a program.

In order that a program director may successfully produce a show, a means of dispatching information to a number of strategic points must be provided. To accomplish this, a separate talkback circuit consisting of a microphone, BA-14A ampli-

fier, four relays and four control keys, is included as part of this system. The four lever key switches are to be located near the program director's point of operation. These circuits permit talkback to the following points by interrupting the program monitor circuit:

1. Projection Room.
2. Studio.
3. Announce Booth.
4. Order Wire Circuit.

The order wire circuit is normally connected into a video switching unit such as a TS-10A switcher. This TS-10A switching panel also provides a two-way phone circuit between the camera operator and the video operator.

The various amplifiers, equalizers, relays, isolation transformers, and six 33A jack strips are assembled and wired in a standard BR-84B cabinet rack which may be mounted as a single unit or in line with other equipment racks that are required as part of the overall television installation.

A number of these systems have been installed and are daily feeding programs to the local stations and in some instances, to a network. It has all the essential facilities required for a small studio installation, and its circuit flexibility has proven its worth on more than one occasion.

Communications Engineers Build Your Future With RCA

RCA Service Company, a Radio Corporation of America subsidiary, is offering communications engineers experienced in installation and maintenance of broadcast and TV transmitters, an outstanding opportunity. We need qualified men to fill Field Engineering positions as RCA representatives with the military at overseas locations. Work involves installation and maintenance of electronics equipment, including communications transmitters, radar, sonar, loran and teletype. Starting salaries are attractive and are reviewed periodically for increase. In addition, overseas bonus, living expenses and full coverage under our liberal group life, disability and hospital-surgical insurance programs are granted. Excellent opportunity for later association with the large scale commercial activities of the company.

Write us today, enclosing a detailed resume of your training and experience. Qualified applicants will be interviewed promptly at a convenient location.

Address:

Government Employment Section
RCA SERVICE COMPANY, Inc.
Camden, New Jersey

FIG. 8. Another studio setup (courtesy of WFIL-TV) which shows how the RCA boom and microphone arrangement can be used to accommodate a small stage group, yet allowing them sufficient freedom of action.



RCA Equipment in



WJZ-TV. RCA field equipment in action atop a WJZ-TV field truck. WJZ-TV also uses RCA television camera controls, microwave relay equipment, sync generators, studio cameras, video and audio control-room console, complete film facilities, turntables, microphones, Superturnstile antenna, and the 5-kw transmitter Type TT-5A.

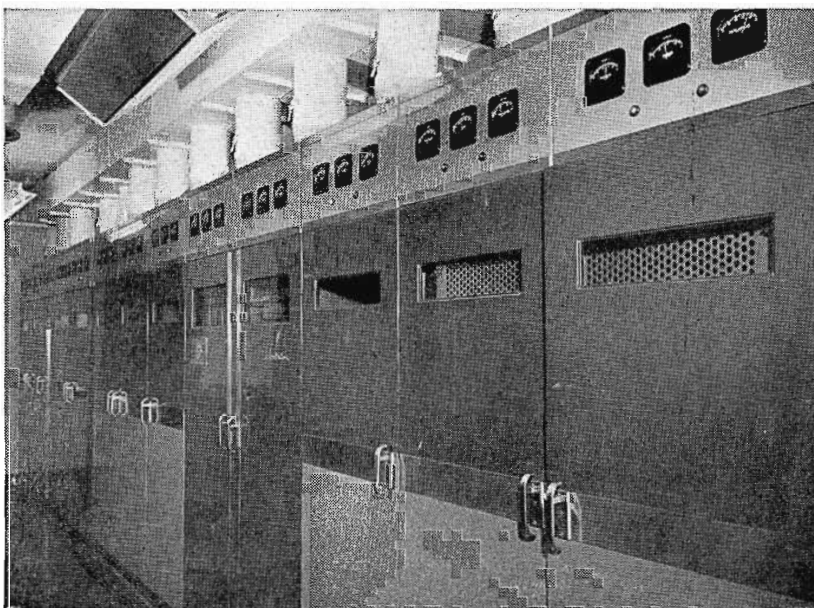

WENR-TV. The RCA 5-kw television transmitter Type TT-5A and RCA 10-kw FM transmitter Type BTF-10B at WENR-TV. This station also includes an RCA Superturnstile antenna, field truck and field camera equipment, studio cameras, video and audio control-room equipment, film projectors, film cameras, turntables, and microphones.

ABC-TV Stations

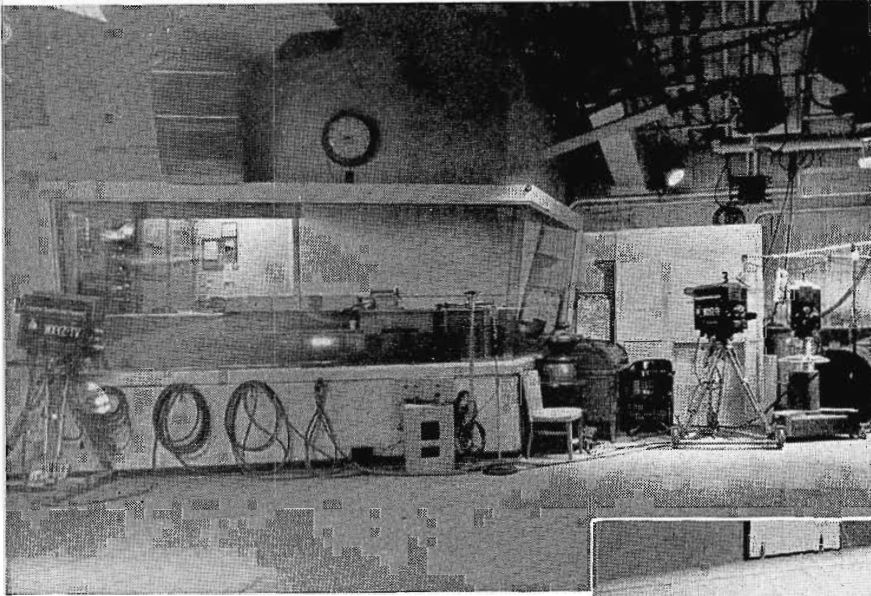

WXYZ-TV. One of the WXYZ-TV studios showing RCA studio cameras and the RCA-equipped control room. WXYZ-TV also uses RCA television field trucks, sync generator, microwave relay equipment, film projectors, slide projectors, film cameras, turntables, microphones, transmitter equipment—including the RCA TT-5A 5-kw transmitter and an RCA Superturnstile antenna.

KECA-TV. KECA-TV's television field truck—like many other TV stations—is an RCA "studio on wheels." It is complete with RCA image orthicon cameras, camera tripods, camera control units, on-the-air master monitor, camera switching system, sync generator, microwave relay equipment, power supplies. KECA-TV also uses RCA studio cameras, film equipment, turntables, microphones, and an RCA Superturnstile antenna.

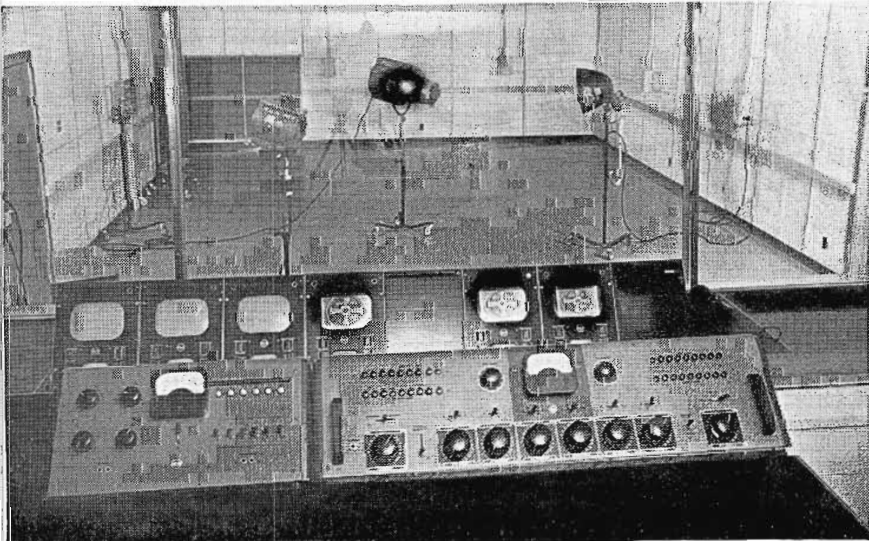

KGO-TV. Video control-room equipment at KGO-TV is completely RCA. KGO-TV also uses RCA field cameras, microwave relay equipment, field truck, sync generator, studio cameras, film projectors, slide projectors, film cameras, turntables, microphones and an RCA Superturnstile antenna.



TELEVISION BROADCAST EQUIPMENT
RADIO CORPORATION of AMERICA
ENGINEERING PRODUCTS DEPARTMENT, CAMDEN, N.J.

In Canada: RCA VICTOR Company Limited, Montreal

RCA TELEVISION

First choice of ALL the Americas!

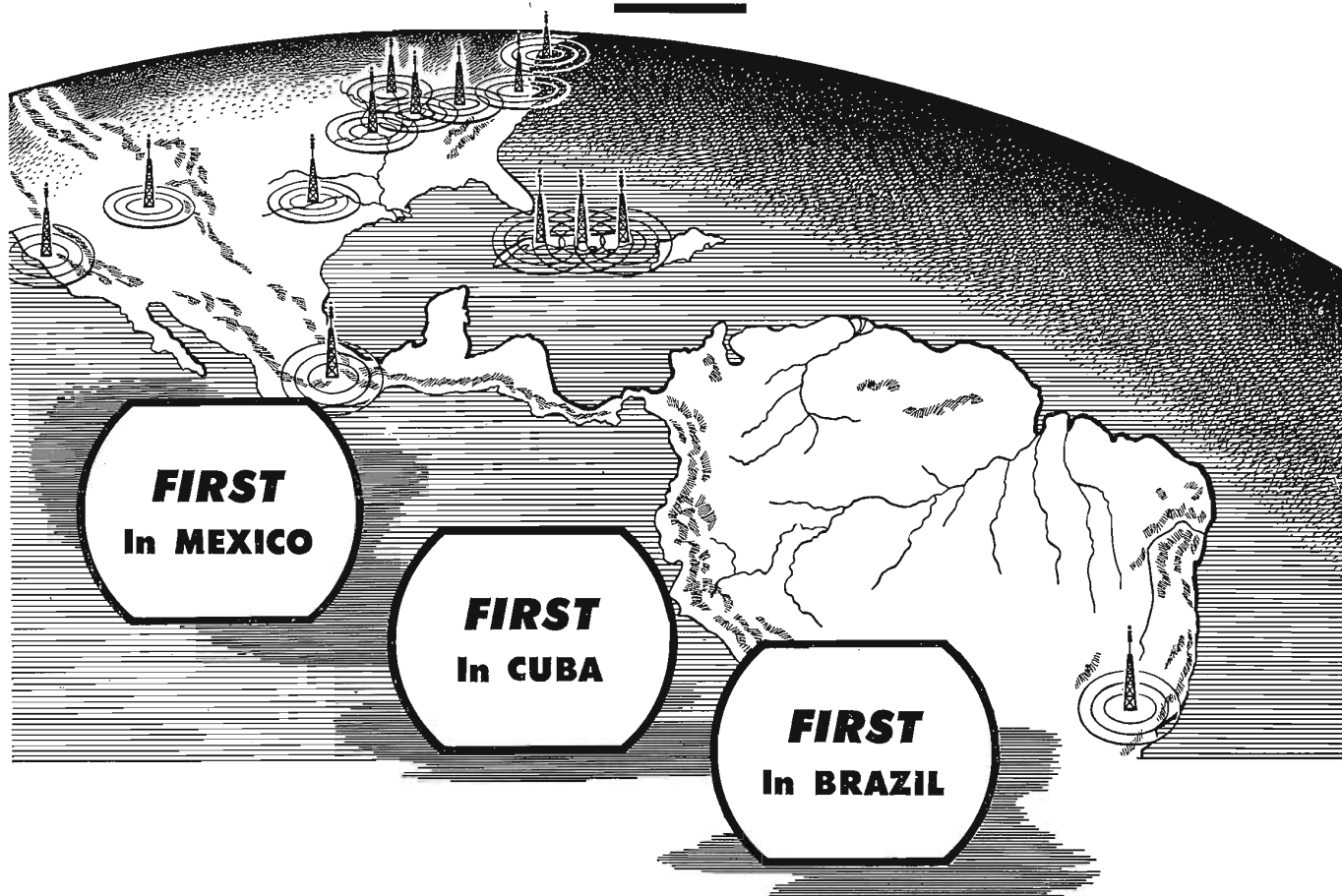

RCA is proud to welcome Mexico, Cuba, and Brazil—their great audience, and their great creative talents—into the family of RCA Television. The first stations to bring video programs to Mexico, Cuba, and Brazil are completely RCA equipped.

In the United States of America, the great *majority* of television stations have installed RCA transmitters and associated equipment. RCA is the first choice of *all* the Americas.

Television, the new teacher, is helping to train and to educate, as well as to entertain.

Your RCA Distributor will be glad to keep you fully informed on

RCA television and its great possibilities in the economy and the culture of your country.

RCA salutes Latin America's pioneers in television:

BRAZIL

PRF3TV—Emissoras Associadas
São Paulo

CUBA

Union Radio, Havana
CMQ—Havana
Telenews Co., Alonso, S.A.*, Havana

MEXICO

XHTV—Television de Mexico, S.A.,
Mexico, D.F.

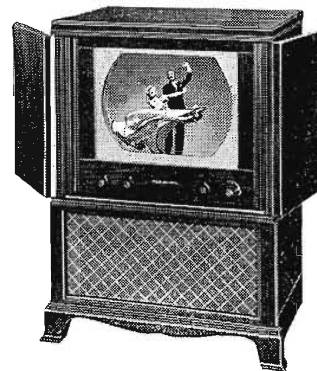

More than a million RCA TV Receivers are in use in homes in the U.S.A.

RCA television receivers inherit the manufacturing and design experience poured by RCA into the more than 1,000,000 RCA television sets now in use in the U.S.A. More than 20 years of experience and \$50,000,000 in video research have made RCA quality and performance the finest in television.

*Under construction



RCA INTERNATIONAL DIVISION

RADIO CORPORATION of AMERICA

RCA BUILDING

30 ROCKEFELLER PLAZA, NEW YORK, N.Y., U.S.A.

World Leader in Radio . . . First in Sound . . . First in Television

RCA SUPER Carfone 2-way radio system

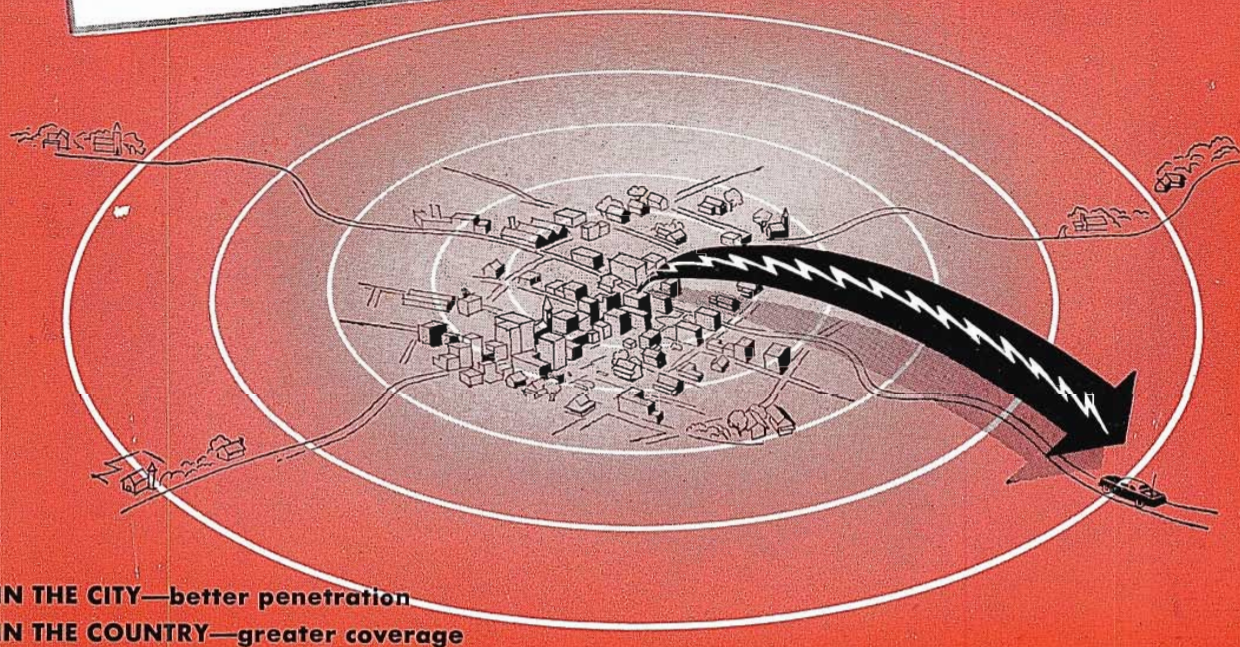

—for areas where the going is TOUGH!

- Gets through in all kinds of terrain
- Causes no interference to neighboring systems
- Pierces poor radio locations
- Clear reception through interference
- Improved message intelligibility

Now reliable communication in congested metropolitan areas is a *practical reality*—with the RCA SUPER Carfone System.

For example, radio vehicles can operate to within a few feet of adjacent-channel stations without receiving interference. Mobile units have the power to "override" the dead spots—communicate from inside the radio shadows of tall buildings and high hills. In the open country, a SUPER Carfone can increase your coverage *as much as 20%*. And that's not all!

SUPER Carfone Systems are engineered to do away with interference to other services, such as television, air navigation, and neighboring communication systems. Mobile units save substantially on tubes and battery...because they operate at low current on standby. Dynamic balancing reduces mechanical vibration—adds materially to equipment endurance.

Let us put complete information in your hands at once. Write Dept. 121K, RCA Engineering Products, Camden, N. J.—today!

RCA SUPER Carfone System 152-174 Mc

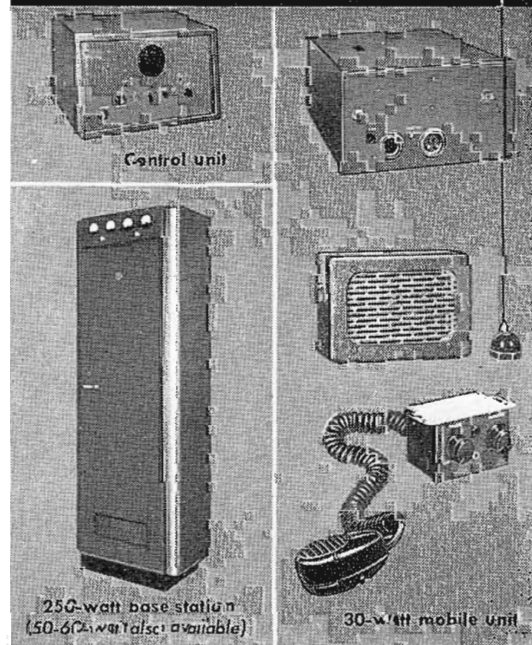

MOBILE COMMUNICATIONS SECTION
RADIO CORPORATION of AMERICA
ENGINEERING PRODUCTS DEPARTMENT, CAMDEN, N. J.

In Canada: RCA VICTOR Company Limited, Montreal

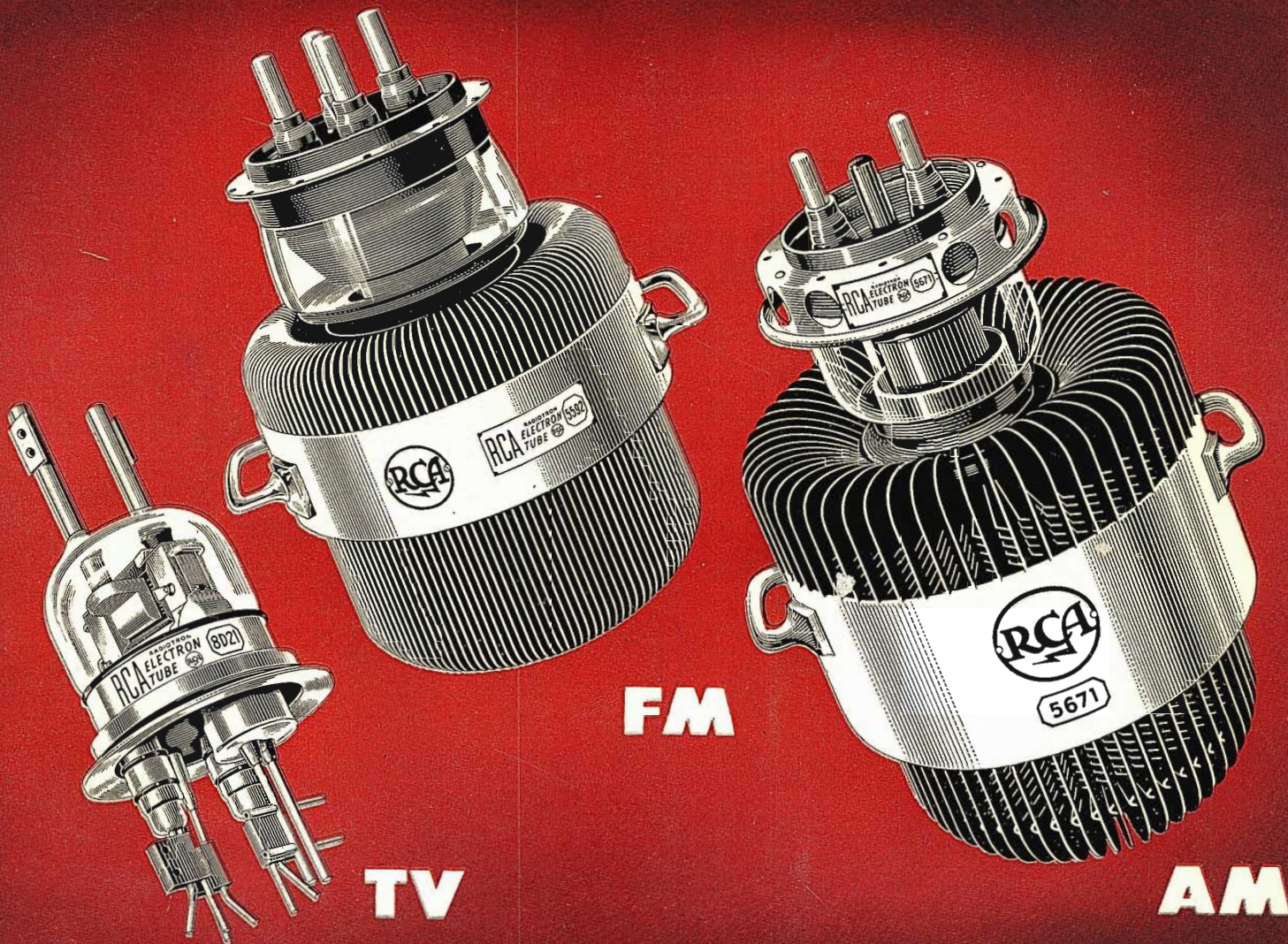

RCA-8D21, used in 5-kw TV transmitters

RCA-5592, used in 50-kw FM transmitters

RCA-5671, has thoriated-tungsten filament, used in 50-kw AM transmitters

Value Beyond Price

THE THREE TUBES illustrated are striking examples of RCA's pioneering in modern tube development . . . the kind of engineering leadership that adds *value beyond price* to the RCA tubes you buy.

The RCA-8D21 employs advanced principles of screening, cooling, and electron optics as revolutionary as television itself. The RCA-5592, with its "metal header" construction, requires no neutralization in grounded-grid circuits. The high-power tube RCA-5671 successfully employs a thoriated-tungsten filament that draws 60% less filament power than similar tungsten-filament types. This tube is establishing exceptional records of life performance.

RCA's unparalleled research facilities, engineering background, and manufacturing experience contribute to the quality, dependability, and operating economy of every RCA tube you buy. This unusual combination of research, engineering, and manufacturing leadership explains why RCA tubes are accepted as the Standard of Comparison in broadcasting.

The complete line of RCA tubes is available from your local RCA tube distributor, or direct from RCA.

The world's most modern tube plant . . .

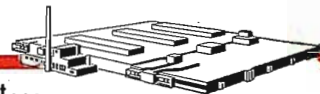

RCA, LANCASTER, PA.

THE FOUNTAINHEAD OF MODERN TUBE DEVELOPMENT IS RCA



RADIO CORPORATION of AMERICA
ELECTRON TUBES

HARRISON, N. J.